



Voyager **XII**



AM Radio
FM Stereo Radio
Cassette Player
CB Radio
Intercom

Audio Systems

Operator's Manual

..... **TABLE OF CONTENTS**

SPECIFICATIONS	3
LOCATION OF PARTS	5
GENERAL INSTRUCTIONS	7
Operating Precautions	7
Theft Prevention	8
AM/FM STEREO RADIO	9
Features	9
AM/FM Stereo Radio Controls	9
How to Listen to the Radio	12
Time Adjustment	13
CASSETTE PLAYER	14
Features	14
Cassette Player Controls	14
How to Play the Cassette Player	16
CB RADIO	18
Features	18
CB Radio Controls	18
How to Operate the CB Radio	19
INTERCOM	21
Features	21
Intercom Controls	21
How to Use the Intercom	22
MAINTENANCE	23
Cleaning the Motorcycle	23
Cassette Player	23

..... SPECIFICATIONS

General	
Power Supply:	
Voltage	12 V (10.8 to 15.6 V) DC, Negative ground
AM/FM Stereo Radio and Cassette Player	
AM Radio:	
Noise Reduction System	Built-in (CZ2)
Receiving Range	530 to 1 620 kHz (10 kHz step)
Intermediate Frequency	450 kHz
Quieting Sensitivity	Less than 35 dB μ (at 20 dB S/N)
Selectivity	More than 30 dB
Distortion	Less than 5%
FM Stereo Radio:	
Noise Reduction System	Built-in
Receiving Range	87.9 to 107.9 MHz (200 kHz step)
Intermediate Frequency	10.7 MHz
Quieting Sensitivity	Less than 18 dB μ (at 30 dB S/N)
Separation	More than 20 dB
Distortion	Less than 5 %
Cassette Player:	
Reproduction System	4 track, 2 channel, 2 program auto-reverse cassette stereo player (Metal tape capable)
Wow and Flutter	Less than 0.2 % (weighted)
"Ground Control" Helmet Sound System:	
Rated Output	0.5 W + 0.5 W (Load impedance = 8 ohms, Stereo)
Output Impedance	16 ohms
Mic Input Impedance	200 ohms
Mic Input Sensitivity	- 70 dBm
General:	
Current Consumption	1.2 A at maximum output 5 mA with back-up (Max.)

Power Amplifier	
Circuit System	B.T.L (Balanced Transformerless) circuit
Rated Output	10 W + 10 W (Load impedance = 4 ohms, 3 % distortion)
Output Impedance	4 ohms
Signal-to-Noise (S/N) Ratio	More than 60 dB
Current Consumption	5 A at maximum output
CB Radio	
General:	
Number of Channels	40 channels (26.965 to 27.405 MHz)
Noise Reduction System	Built-in (CZ2)
Modulation Type	Amplitude modulation
Antenna Impedance	50 ohms
Current Consumption	Less than 3 A
Receiver:	
Quieting Sensitivity	Less than 6 dB μ (at 10 dB S/N)
Intermediate Frequency	1st 10.695 MHz 2nd 455 kHz
Transmitter:	
Radio Frequency (R.F.) Output	4 W maximum (14.0 V)
Speakers	
Type	Cone type, 10 cm dia.
Rated Impedance	4 ohms

LOCATION OF PARTS

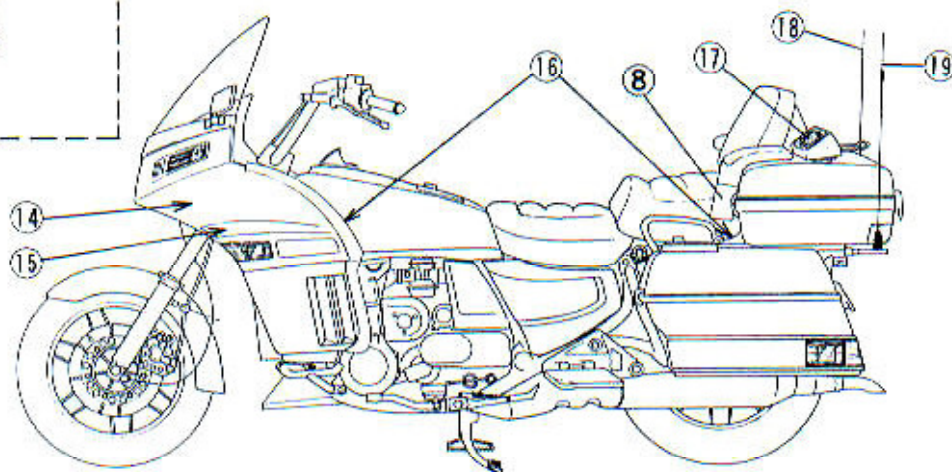
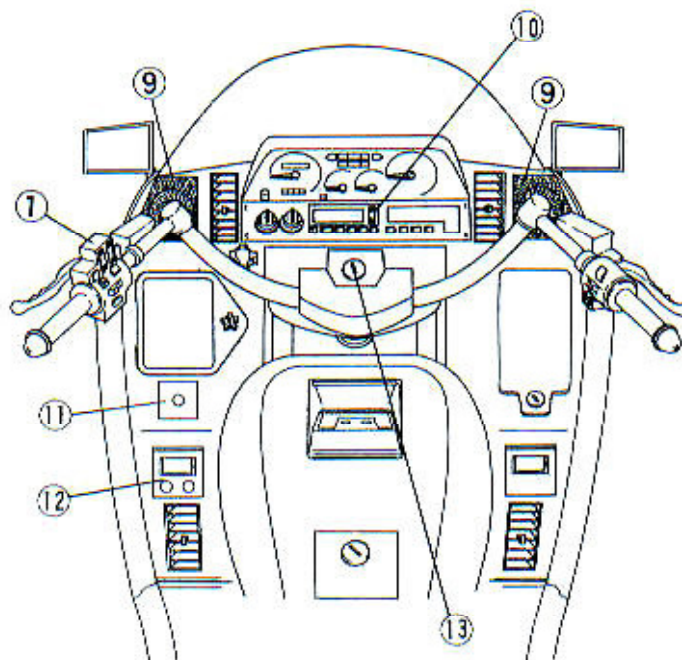
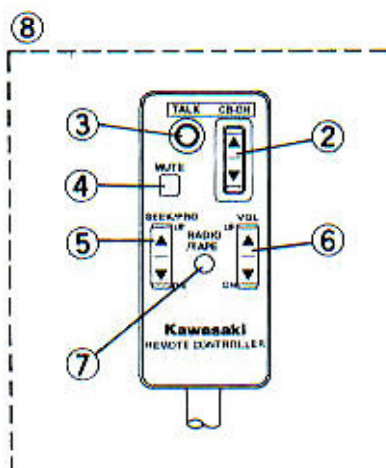
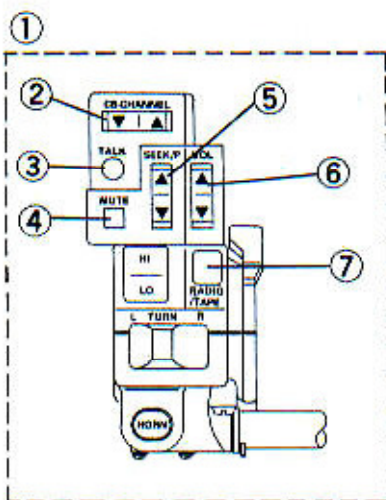

- | | |
|--|--------------------------------|
| 1. Left Handlebar Switches | 11. Fader Control Unit |
| 2. CB Channel Select Switch (Optional) | 12. CB Control Unit (Optional) |
| 3. CB Talk Switch (Optional) | 13. Ignition Switch |
| 4. Muting Switch | 14. Power Amplifier |
| 5. Auto Seek Switch/Program Change Switch | 15. CB Module (Optional) |
| 6. Volume Control Switch | 16. DIN Plugs (Optional) |
| 7. Radio/Tape Button | 17. Rear Speaker |
| 8. Passenger Switches | 18. AM/FM Antenna |
| 9. Front Speaker | 19. CB Antenna (Optional) |
| 10. AM/FM Stereo Radio and Cassette Player | |

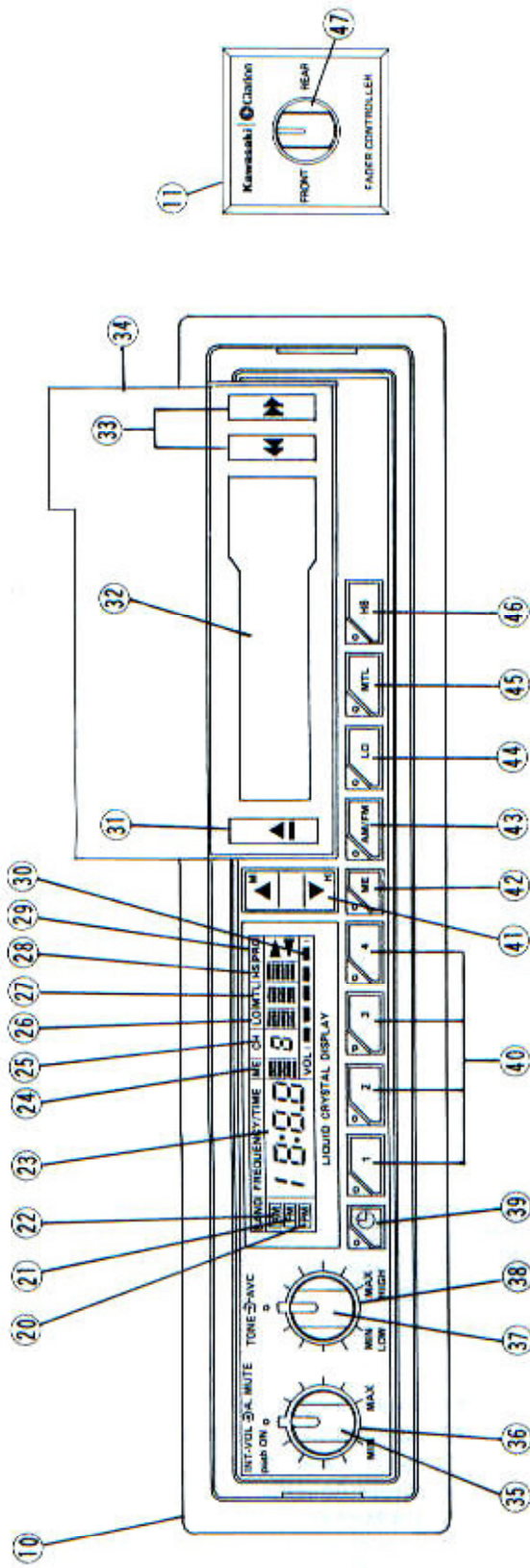

- 20. PM Indicator
- 21. FM Indicator
- 22. AM Indicator
- 23. Radio Frequency/Time Display
- 24. Memory Indicator
- 25. Preset Channel Indicator
- 26. Local Indicator
- 27. Metal Indicator
- 28. Helmet Sound Indicator (Optional)
- 29. Program Indicator
- 30. Volume Indicator
- 31. Stop/Eject Button
- 32. Tape Slot
- 33. F.F./Rew. Buttons
- 34. Tape Slot Door
- 35. Power Switch/Intercom Volume Control (Optional)

- 36. Muting Level Control (Optional)
- 37. Tone Control
- 38. Auto Volume Control
- 39. Time Readout Button
- 40. Preset Tuning Buttons
- 41. Manual Tuning/Time Adjusting Switch
- 42. Memory/Adjusting Button
- 43. Radio Band Select Button
- 44. Local Button
- 45. Metal Button
- 46. Helmet Sound Button (Optional)
- 47. Fader Control
- 48. Transmission Indicator (Optional)
- 49. Receiving Indicator (Optional)
- 50. Power Switch/Volume Control (Optional)
- 51. Channel Indicator (Optional)
- 52. Squelch Control (Optional)

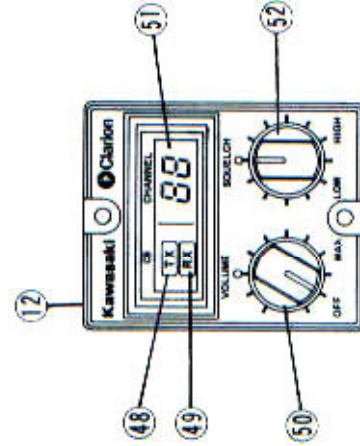

GENERAL INSTRUCTIONS

Operating Precautions

There are a number of important precautions that are musts when operating the audio system. Learn and observe all the rules below.

WARNING

- Keep both hands on the handlebar at all times while riding. Don't remove your hands from the handlebar to adjust audio system controls. Make these adjustments before riding.



Adjust Controls
Before Riding

- Do not operate the audio systems (AM radio, FM stereo radio, cassette player or optional sound devices) at volumes so loud that they interfere with your ability to hear sirens, horns, or other warning signals.

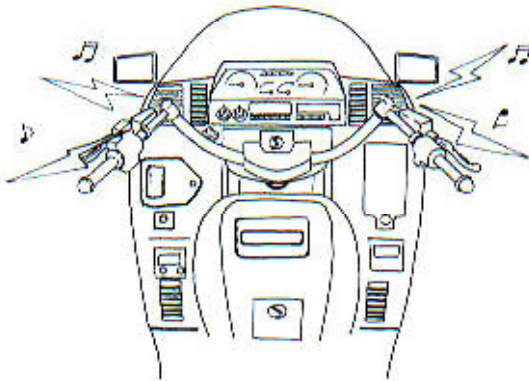

- Do not operate the audio systems at volumes so loud that they disturb other people.

CAUTION

- With the exception of genuine Kawasaki Parts and Accessories, Kawasaki has no control over the design or application of accessories. Kawasaki Parts and Accessories have been specially designed for use on Kawasaki motorcycles. We strongly recommend that all parts and accessories you add to your motorcycle be genuine Kawasaki components.

- Do not use any substitute for the standard fuse. If a fuse is blown, inspect the electrical system to determine the cause, and then replace it with a new one of the correct capacity.

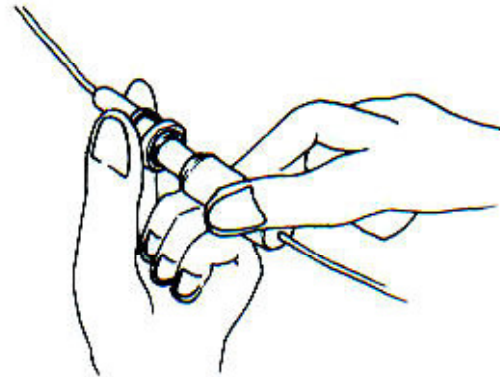

- The audio systems are designed for use with a 12 V DC negative ground system. Do not use the audio systems with other voltages or a positive ground system.

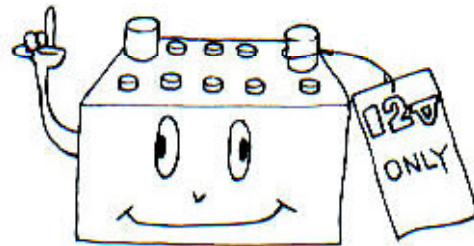

- If you use the AM/FM radio, cassette player or optional equipment for a long time with the engine stopped, the battery may become discharged. When you listen to the AM/FM radio, cassette player or optional equipment with the engine stopped, decrease the volume as far as possible. Increasing the volume increases the power consumption.

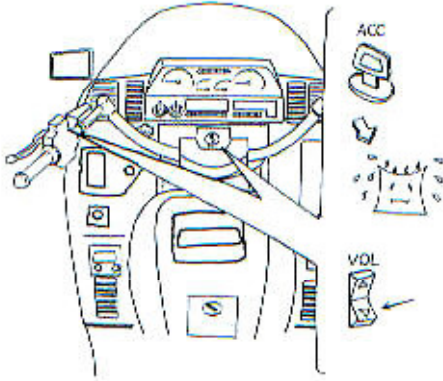

- When the ignition switch is turned OFF, the AM/FM radio preset memory and clock will continue to function with the back-up power supply circuit from the battery. But resetting is required when the battery becomes totally discharged or is disconnected.

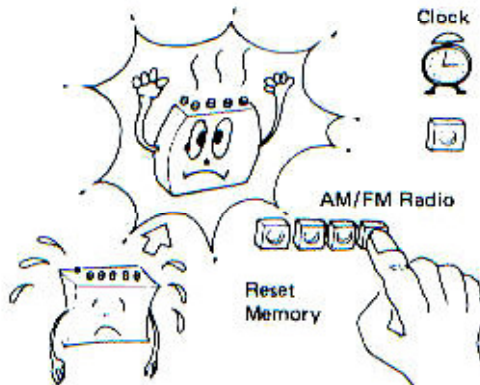

- To prevent damage to the audio systems, always remove the 3A audio fuse in the fuse case when the battery leads are connected and disconnected.
- USE UNGROUNDED SPEAKERS ONLY. Use 4 ohm speakers only. All speaker leads and terminals must be electrically isolated from chassis ground or the amplifier will be damaged.
- Be sure to keep the tape slot door closed except when inserting or removing a cassette to prevent dirt and water from entering and damaging the tape player.
- Always remove a cassette from the player when it is not playing.

Theft Prevention

To help prevent theft, the antenna can be detached from the motorcycle and taken with you.

Antenna Removal

- Turn the lower end of the antenna counter-clockwise and remove the antenna from the motorcycle.

Antenna Installation

- Tighten the antenna securely so that it will not loosen while you are riding.

NOTE

- When you put a cover over the motorcycle, the antenna can be folded down by loosening the locknut.

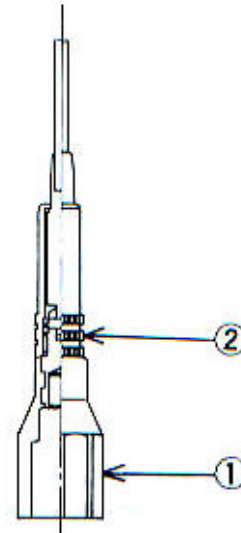

1. Turn to remove.
2. Turn to fold down.

AM/FM STEREO RADIO

Features

- AM/FM stereo electronic tuner, PLL (Phase Locked Loop) frequency synthesizer system with clock function
- Digital quartz clock, 12-hour indication
- Easy-to-read digital display
- Anti-vibration and water-resistant construction
- Manual tuning, preset tuning, and auto seek tuning
- Muting switch, auto seek switch, volume control switch, and radio/tape button are on the left handlebar for the rider and on the travel trunk for the passenger.
- Auto volume control system increases the volume of the speakers automatically as the speed of the vehicle increases.
- Four FM and four AM stations can be preset into memory.
- Antenna can be detached to prevent theft and folded down so the motorcycle may be covered.
- SASC (Signal Actuated Stereo Control) circuit is provided in FM.

This circuit is used to further improve FM reception and widen the service area. Stereo mode is automatically selected when FM stereo signal is being received. However, if the signal is too weak to provide proper reception, the monaural mode is automatically selected to obtain improved reception with low noise. Comfortable FM reception with low noise can thus be enjoyed.

- The AM/FM stereo radio is combined with the cassette player in a compact unit.
- Fader control for front and rear speakers

AM/FM Stereo Radio Controls

Left Handlebar Switches and Passenger Switches:

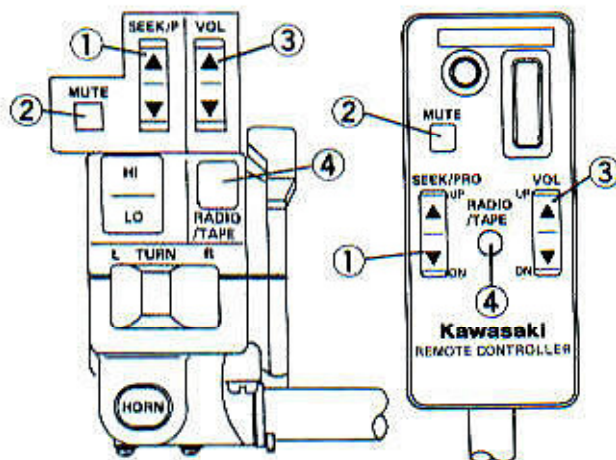

1. Auto Seek Switch
(Program Change Switch in Cassette Mode)
2. Muting Switch
3. Volume Control Switch
4. Radio/Tape Button

1. Auto Seek Switch

Push this rocker type switch to move the radio frequency to the next listenable station in the radio mode. Pushing the "up" symbol (▲) end of the switch moves the frequency up to the next station, and pushing the "down" symbol (▼) end of the switch moves the frequency down to the next station. If you want to seek and tune in another station, push the switch again.

2. Muting Switch

Turn on the muting switch to decrease the radio volume instantly when listening to the radio from the fairing-mounted speakers.

3. Volume Control Switch

Push this rocker type switch to increase or decrease the radio volume. Pushing the ▲ end of the switch increases the volume, and pushing the ▼ end of the switch decreases the volume.

4. Radio/Tape Button

Push this button to select the radio mode or the cassette (tape) mode.

Fader Control Unit:

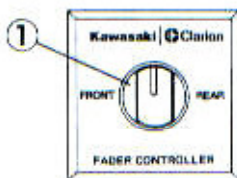

1. Fader Control

Turn the fader control to balance the volume of the front and rear speakers. Turning this control counterclockwise increases the volume of the front speakers and decreases the volume of the rear; turning it clockwise does the opposite.

1. Fader Control

AM/FM Stereo Radio Unit:

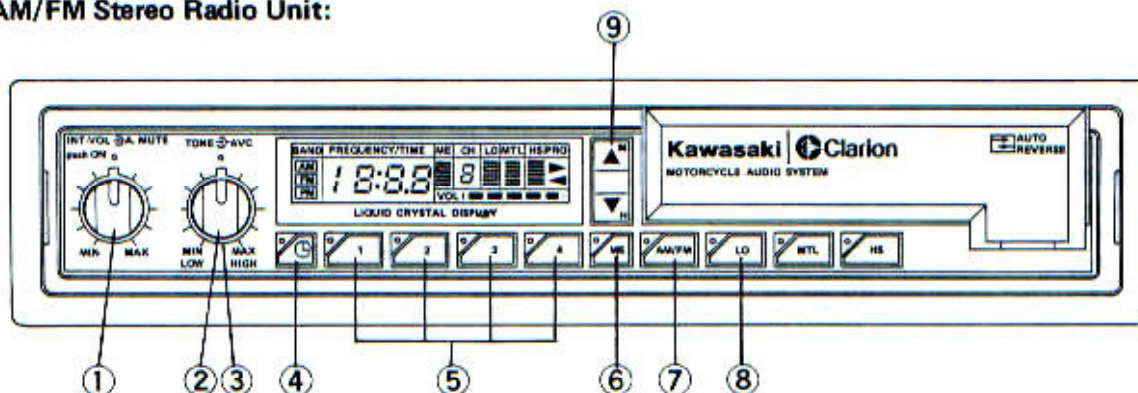

- | | | |
|------------------------|----------------------------|--|
| 1. Power Switch | 4. Time Readout Button | 7. Radio Band Select Button |
| 2. Tone Control | 5. Preset Tuning Buttons | 8. Local Button |
| 3. Auto Volume Control | 6. Memory/Adjusting Button | 9. Manual Tuning/Time Adjusting Switch |

1. Power Switch

Push this switch to turn on the audio systems.

2. Tone Control

Rotate the tone control clockwise to emphasize treble. Treble is attenuated by rotating the control counterclockwise.

3. Auto Volume Control

The volume of the fairing-mounted speakers increases as the speed of the vehicle increases. This auto volume control is used to adjust the operating level. Turn the auto volume control clockwise to raise the operating level.

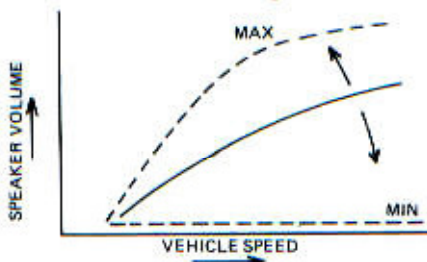

4. Time Readout Button

Push this button to show the time when the display shows the radio frequency (in radio mode). The time will be indicated for about 5 seconds after this button is pushed, then the display will return to the radio frequency.

5. Preset Tuning Buttons

Four AM stations and four FM stations (one AM and one FM for each preset tuning button) can be preset in the memory. Refer to "Preset Tuning" in the "How to Listen to the Radio" section.

6. Memory/Adjusting Button

This button is used to preset an AM or FM station in the memory or to adjust the time. Refer to "Preset Tuning" in the "How to Listen to the Radio" section and to the "Time Adjustment" section.

7. Radio Band Select Button

Push this button to select the AM band or the FM band.

8. Local Button

This button works only when using the auto seek switch. If the station's signal is too strong, push the local button to reduce the signal strength a little. If the station's signal is weak, push the local button again to return to normal operation.

9. Manual Tuning/Time Adjusting Switch

Push this rocker type switch to tune in the desired radio station in the radio mode. Refer to "Manual Tuning" in the "How to Listen to the Radio" section.

When the audio system is in the cassette mode, this switch becomes the time adjusting switch. Refer to the "Time Adjustment" section.

Display:

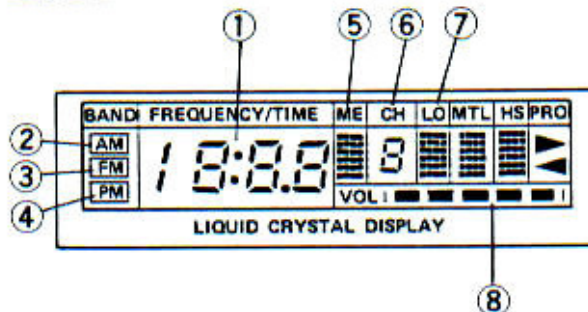

1. Radio Frequency/Time Display

2. AM Indicator

3. FM Indicator

4. PM Indicator

5. Memory Indicator

6. Preset Channel Indicator

7. Local Indicator

8. Volume Indicator

1. Radio Frequency/Time Display

This display indicates both the radio frequency and the time. In the radio mode, the radio frequency is indicated on the display. Ordinarily the time is indicated on the display even if the ignition switch is in the "OFF" position.

2. AM Indicator

The AM indicator appears on the display in the morning (in the cassette mode) and while an AM radio signal is being received (in the radio mode).

3. FM Indicator

The FM indicator appears on the display while an FM radio signal is being received.

4. PM Indicator

The PM indicator appears on the display after noon.

5. Memory Indicator

When the audio system is in the radio mode, the memory indicator will appear on the display for about 5 seconds after the memory/adjusting button is pushed. Refer to "Preset Tuning" in the "How to Listen to the Radio" section.

6. Preset Channel Indicator

The preset channel indicator shows the preset channel (station) selected both when listening to the preset channel and when presetting the radio frequency.

7. Local Indicator

The local indicator appears on the display when the local button is pushed to reduce signal strength.

8. Volume Indicator

The volume indicator shows the volume level set by the volume control switch. As the volume increases, the indicator blocks appear one by one from the left.

How to Listen to the Radio

WARNING

○Carefully read the "GENERAL INSTRUCTIONS" chapter before operating the radio. Learn and observe all the rules.

Switching on the Radio:

- Turn the ignition switch to the "ACC" or "ON" position. At this time, the display will light up.
- Push the power switch to turn on the audio system. All switch position indicators will appear when the power comes on.
- Push the radio/tape button if the display shows the time (cassette mode).
- Select the AM or FM band. At this time, AM or FM indicator will appear on the display.

Tuning:

NOTE

○When the radio is turned off and then turned on again, memory in the radio will automatically return to the last station selected.

Manual Tuning

- Push the manual tuning/time adjusting switch to tune in the desired station. Pushing the "up" symbol (▲) end of the switch moves the frequency from low to high, and pushing the "down" symbol (▼) end of the switch moves the frequency from high to low. Pushing the switch momentarily increases or decreases the frequency by 10 kHz for AM or by 200 kHz for FM. Pushing and holding the switch increases or decreases the frequency continuously in 10 kHz steps for AM or in 200 kHz steps for FM.

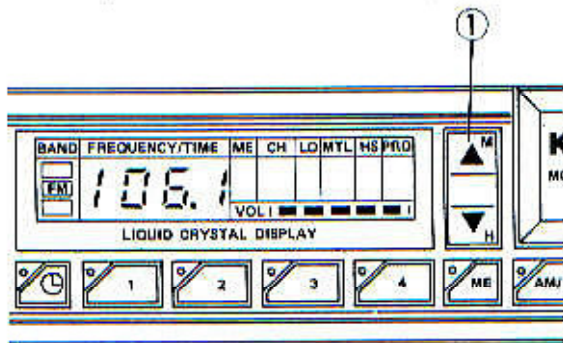

1. Manual Tuning/Time Adjusting Switch

Auto Seek Tuning

- Push the auto seek switch to move the radio frequency to the next listenable station in the radio mode. Pushing the "up" symbol (▲) end of the switch moves the frequency up to the next station, and pushing the "down" symbol (▼) end of the switch moves the frequency down to the next station.
- Once the station selection is completed, the display stops and indicates the frequency selected.
- If you want to seek and tune in another station, push the switch again.

NOTE

○When the radio passes the last listenable station at the highest frequency, it starts to seek the first listenable station beginning at the lowest frequency and when it passes the lowest frequency, it begins again at the highest.

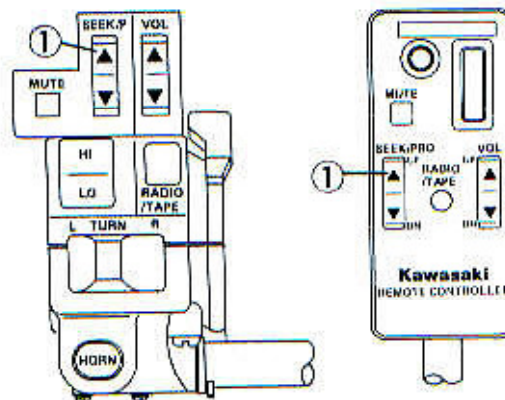

1. Auto Seek Switch

Preset Tuning

NOTE

○When the battery becomes discharged or is disconnected, the preset memory is erased and following frequencies are set into memory.

Band	Preset Tuning Button			
	1	2	3	4
AM	530 kHz	600 kHz	1 000 kHz	1 400 kHz
FM	87.9 MHz	90.1 MHz	98.1 MHz	106.1 MHz

- Tune in the desired station (auto seek tuning or manual tuning), and check that the radio frequency is shown on the display.
- Push the memory/adjusting button. At this time, the memory indicator will appear on the display for about 5 seconds. The memory can be set only while the memory indicator appears on the display.
- While the memory indicator appears on the display, push any one of the four preset tuning buttons. When the station is preset in the memory, the memory indicator will disappear.
- You can preset into memory 4 AM and 4 FM stations (one AM and one FM station for each preset tuning button).
- After presetting, push the appropriate preset tuning button to tune in the desired station.

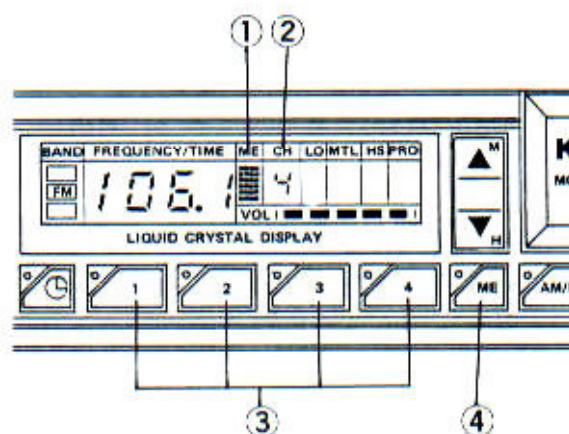

1. Memory Indicator
2. Preset Channel Indicator
3. Preset Tuning Buttons
4. Memory/Adjusting Button

Switching off the Radio:

- Push the power switch. At this time, all switch position indicators will disappear.
- Turn off the ignition switch.

Time Adjustment

When the ignition switch is in the "OFF" position, the clock functions with the back-up power supply circuit from the battery. But, reset is required when the battery becomes discharged or is disconnected.

NOTE

○When the battery becomes discharged or is disconnected, the time display is reset to "AM 1:00."

- Check that time is shown on the display. Time adjustment can be done whenever the display shows the time.
- With the memory/adjusting button depressed, push the manual tuning/time adjusting switch to "M" to adjust the minutes or to "H" to adjust the hour. Pushing the switch momentarily advances the hour or minute step by step. Pushing and holding the switch advances the hour or minutes continuously.
- Check that the AM or PM indicator is appropriate for the time of day. If it is not, advance the time by 12 hours.

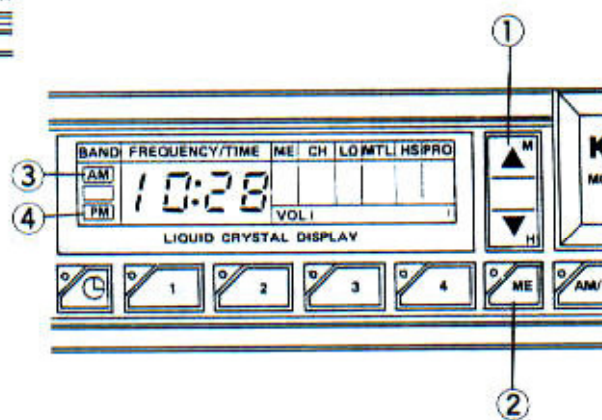

1. Manual Tuning/Time Adjusting Switch
2. Memory/Adjusting Button
3. AM Indicator
4. PM Indicator

CASSETTE PLAYER

Features

- Auto reverse mechanism
- Anti-vibration and water-resistant construction
- Metal tape compatibility
- Muting switch, program change switch, volume control switch, and radio/tape button are on the left handlebar for the rider and on the travel trunk for the passenger.
- Auto volume control system increases the volume of the speakers automatically as the speed of the vehicle increases.
- The cassette player is combined with the AM/FM stereo radio in a compact unit.
- Fader control for front and rear speakers

1. Program Change Switch

Push this rocker type switch to change the cassette tape program (reverse tape play direction) in the cassette mode.

2. Muting Switch

Refer to the "AM/FM STEREO RADIO" chapter.

3. Volume Control Switch

Refer to the "AM/FM STEREO RADIO" chapter.

4. Radio/Tape Button

Refer to the "AM/FM STEREO RADIO" chapter, noting the following:

Push this button to stop the tape temporarily when playing the cassette, and push it again to start the tape.

Cassette Player Controls

Left Handlebar Switches and Passenger Switches:

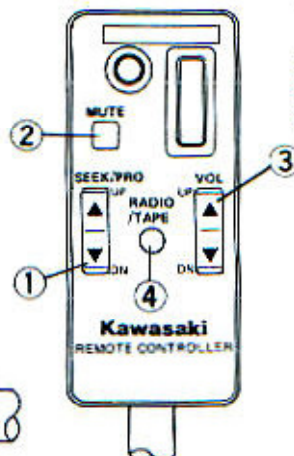
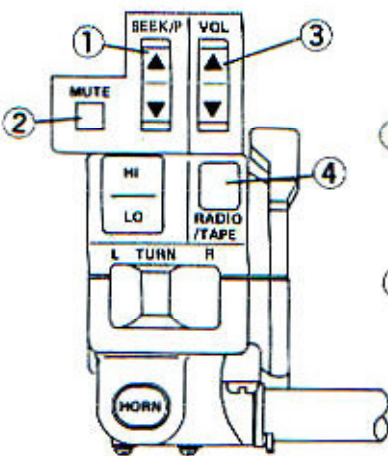

1. Program Change Switch (Auto Seek Switch In Radio Mode)
2. Muting Switch
3. Volume Control Switch
4. Radio/Tape Button

Fader Control Unit:

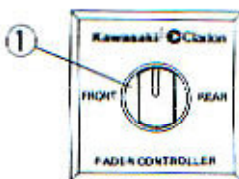

1. Fader Control

1. Fader Control

Refer to the "AM/FM STEREO RADIO" chapter.

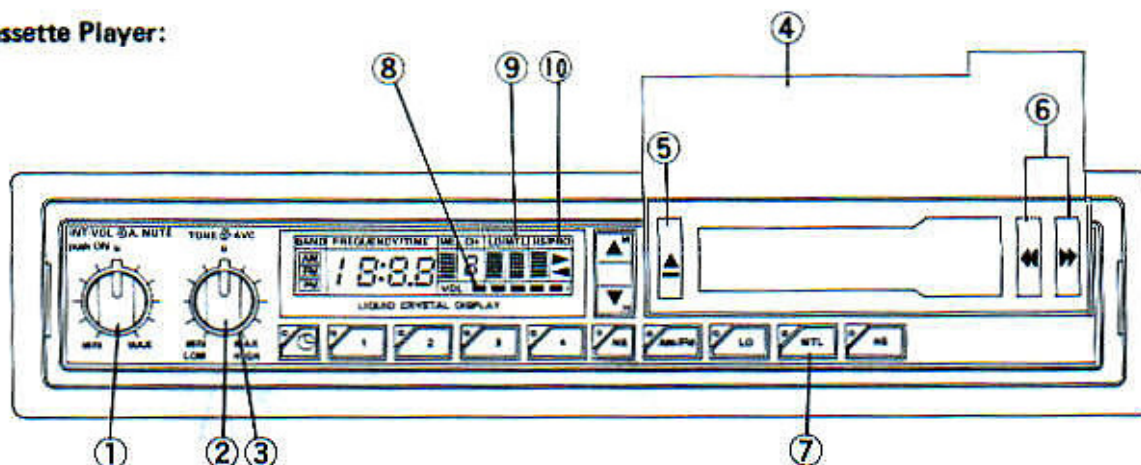
Cassette Player:

- | | | |
|------------------------|---|-----------------------|
| 1. Power Switch | 5. Stop/Eject Button | 8. Volume Indicator |
| 2. Tone Control | 6. F.F./Rew. Buttons
(Fast Forward/Rewind) | 9. Metal Indicator |
| 3. Auto Volume Control | 7. Metal Button | 10. Program Indicator |
| 4. Tape Slot Door | | |

1. Power Switch
Refer to the "AM/FM STEREO RADIO" chapter.

2. Tone Control
Refer to the "AM/FM STEREO RADIO" chapter.

3. Auto Volume Control
Refer to the "AM/FM STEREO RADIO" chapter.

4. Tape Slot Door
Open this door to insert or remove a cassette.

5. Stop/Eject Button
This button cancels the fast forward or rewinding of the tape when pushed lightly. It ejects the cassette when pushed firmly.

6. F.F./Rew. Buttons (Fast Forward/Rewind)
These buttons move the tape rapidly in either direction. They are locking and, therefore, do not have to be held continuously while advancing or rewinding the tape.

7. Metal Button
Push this button when metal tape is used to match the tape's capability.



8. Volume Indicator
Refer to the "AM/FM STEREO RADIO" chapter.

9. Metal Indicator
The metal indicator will appear on the display when the metal button is pushed.

10. Program Indicator (▶ or ◀)
The two program indicators (▶ or ◀) show the direction of tape movement and the program being played (A or B).

(a) The ▶ Indicator
The ▶ indicator appears when the tape is moving counterclockwise and the program recorded on the side facing up (side A illustrated below) is playing.

(b) The ◀ Indicator
The ◀ indicator appears when the tape is moving clockwise and the program recorded on the side facing down is playing.

Cassette with Side A Facing Up	Program Indicator	Side Playing
	▶	Side A
	◀	Side B

How to Play the Cassette Player

WARNING

- Carefully read the "GENERAL INSTRUCTIONS" chapter before operating the cassette player. Learn and observe all the rules.

Switching on the Cassette Player:

- Turn the ignition switch to the "ACC" or "ON" position. At this time, the display will light up.
- Push the power switch to turn on the audio system. All switch position indicators will appear when the power comes on.
- Push the radio/tape button if the display shows the radio frequency (radio mode).
- When a metal tape is loaded, push the metal button and check that the metal indicator appears on the display.

Playing a Cassette Tape:

Loading a Cassette Tape

- Open the tape slot door.
- Insert the cassette into the tape slot with the exposed tape side facing right. At this time, a program indicator will appear on the display and the tape will automatically start.
- Close the tape slot door.
- Adjust the volume and tone.
- Adjust the auto volume control if necessary.

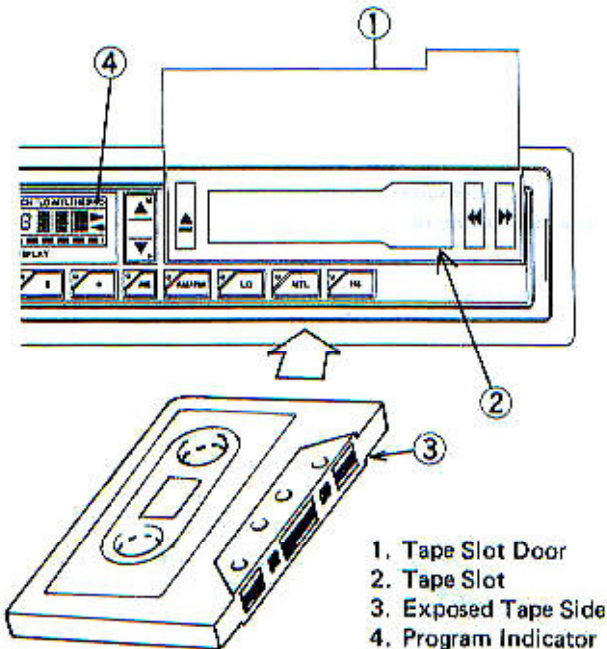

CAUTION

- A tape that is loose or slack inside the cassette case may become wound around the capstan or pinch roller. To avoid this problem, tighten the tape by using a pencil or other suitable implement as shown.

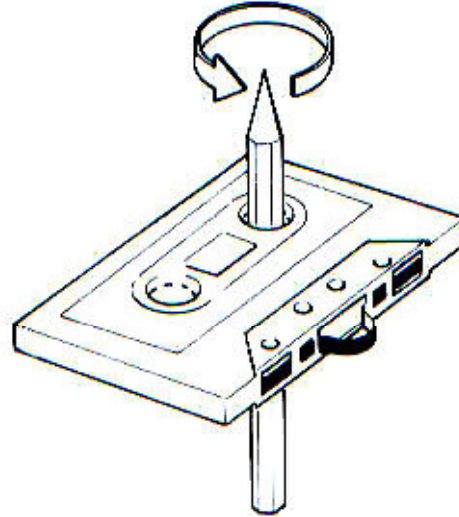

NOTE

- The C-120 tapes are extremely thin and weak, and the magnetic coating is also thin. These tapes may cause distorted sound and also may wrap around the capstan causing jamming. C-120 tapes, therefore, are not recommended for use in this cassette player.

Changing Program

- Push the program change switch to change cassette programs. It is not necessary to remove the cassette and turn it over.

NOTE

- The program indicators will show the change in tape movement direction when you push the program change switch.
- When the tape reaches the end during normal play or when advanced or rewound with a F.F./Rew. button, the auto-reverse mechanism will begin play in the opposite direction. The program indicators will change also to show that the program has changed.

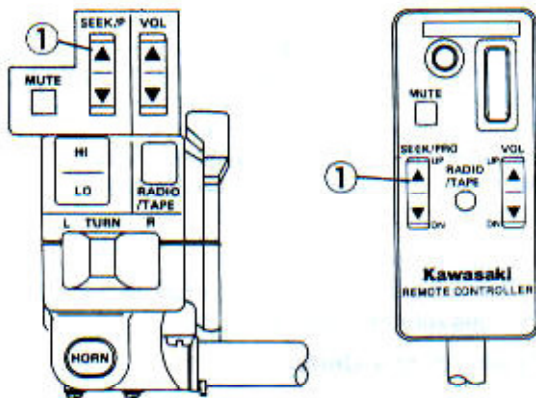

1. Program Change Switch

Advancing or Rewinding the Tape

- Open the tape slot door.
- With a cassette tape playing, check the program indicator to determine which direction the tape is moving.

- ▶ = tape is moving counterclockwise.
- ◀ = tape is moving clockwise.

- If the ▶ indicator appears, push the right F.F./Rew. button to advance the tape and push the left F.F./Rew. button to rewind the tape.

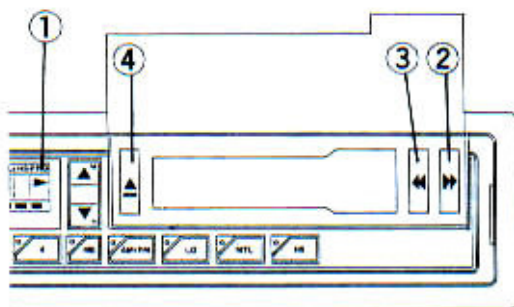

1. Program Indicator
2. Push this button to advance the tape.
3. Push this button to rewind the tape.
4. Stop/Eject Button

- If the ◀ indicator appears, push the left F.F./Rew. button to advance the tape and push the right F.F./Rew button to rewind the tape.

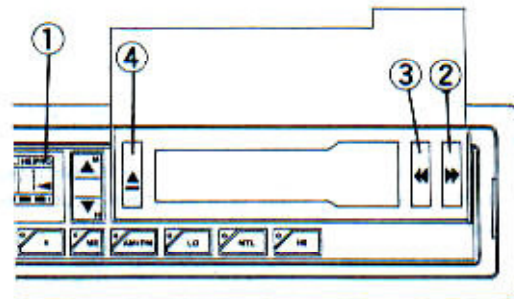

1. Program Indicator
2. Push this button to rewind the tape.
3. Push this button to advance the tape.
4. Stop/Eject Button

NOTE

- When an F.F./Rew. button is depressed, lightly push the stop/eject button to cancel it.
- Fast feeding of the tape will be cancelled and play back will begin when the tape is advanced or rewound to the end.

Ejecting a Cassette Tape

- Open the tape slot door.
- Push the stop/eject button firmly to eject the cassette.
- Take the cassette out of the tape slot.
- Close the tape slot door.

Switching off the Cassette Player:

- Push the power switch. At this time, all switch position indicators will disappear.
- Turn off the ignition switch.

CB (Citizens Band) RADIO

Features

- 40-channel CB transceiver
- Easy-to-read digital channel display
- Anti-vibration and water-resistant construction
- Noise reduction circuit
- Transmission and channel selection by switches on handlebar for rider and on travel trunk for passenger
- Squelch control

CB Radio Controls

Left Handlebar Switches and Passenger Switches:

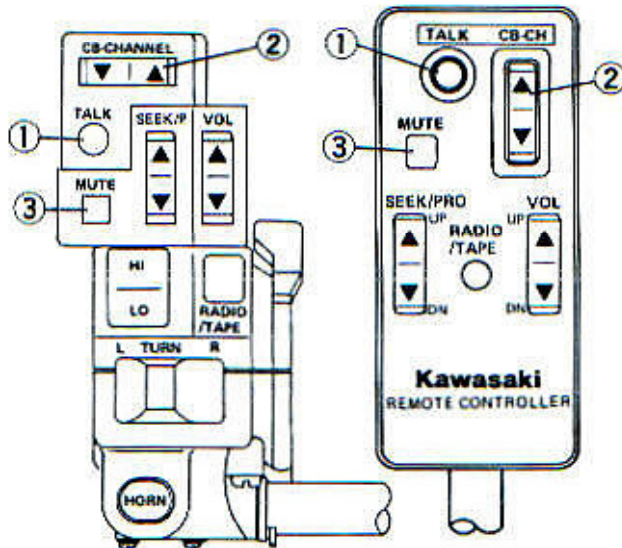

1. Talk Switch
2. Channel Select Switch
3. Muting Switch

1. Talk Switch

Push this button to activate the transmitter, and release it to activate the receiver.

Refer to the "How to Operate the CB Radio" section.

2. Channel Select Switch

Select the channel by pushing this switch. Pushing the switch ▲ or ▼ moves the channel (frequency) up or down respectively. Pushing the switch momentarily changes the channel to the next one. Pushing and holding the switch changes channels continuously.

3. Muting Switch

Push the muting switch button to decrease receiving volume instantly.

Fader Control Unit:

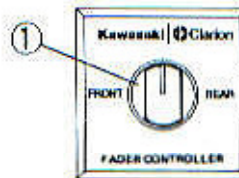

1. Fader Control

1. Fader Control

Refer to the "AM/FM STEREO RADIO" chapter.

Control Unit:

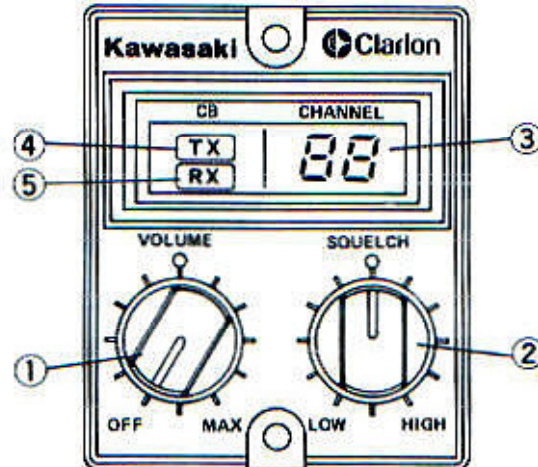

1. Power Switch/Volume Control
2. Squelch Control
3. Channel Indicator
4. Transmission Indicator
5. Receiving Indicator

1. Power Switch/Volume Control

This switch is used to turn on or off the CB radio and control the receiver volume.

Refer to the "How to Operate the CB Radio" section

2. Squelch Control

This control is used to eliminate background noise. Turn this control clockwise until the noise is eliminated. Refer to the "How to Operate the CB Radio" section.

3. Channel Indicator

The channel indicator shows the selected channel (frequency) on the display while power is supplied to the CB radio.

Channel:	Frequency (MHz)
1	26.965
2	26.975
3	26.985
4	27.005
5	27.015
6	27.025
7	27.035
8	27.055
9	27.065
10	27.075
11	27.085
12	27.105
13	27.115
14	27.125
15	27.135
16	27.155
17	27.165
18	27.175
19	27.185
20	27.205
21	27.215
22	27.225
23	27.255
24	27.235
25	27.245
26	27.265
27	27.275
28	27.285
29	27.295
30	27.305
31	27.315
32	27.325
33	27.335
34	27.345
35	27.355
36	27.365
37	27.375
38	27.385
39	27.395
40	27.405

4. Transmission Indicator

The transmission indicator appears on the display while the rider and/or passenger are transmitting (the talk switch is turned on).

5. Receiving Indicator

The receiving indicator appears on the display while CB signals are being received.

DIN Plugs:

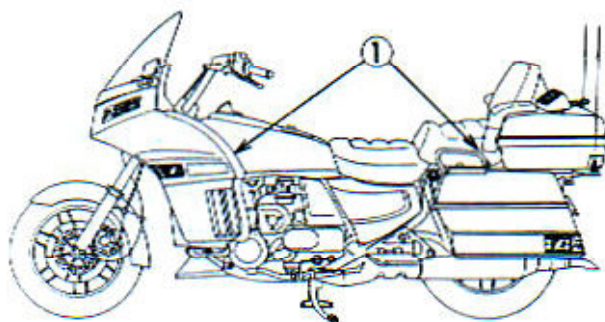

1. DIN Plugs

1. DIN Plugs

Two DIN plugs are provided for connecting the "Ground Control" helmet sound system.

How to Operate the CB Radio

WARNING

- This CB radio has been approved by the Federal Communications Commission (F.C.C.) in the U.S.A. and the Department Of Communications (D.O.C.) in Canada, and has the "type acceptance" labels on it. Before operating a CB transmitter in Canada, you must have authority from the D.O.C. in Canada. Also, you must agree to follow the rules set by the D.O.C. in Canada. Effective June 1983 a license to operate a citizens band radio is no longer required in the U.S.A. Read the rules for operating a CB transmitter carefully. Following them is the least you can do to become a good CBer.
- Carefully read the "GENERAL INSTRUCTIONS" chapter before operating the CB radio. Learn and observe all the rules.

Switching on the CB Radio:

- Connect the "Ground Control" helmet connecting cords to the DIN plugs for the rider and/or passenger.
- Turn the ignition switch to the "ACC" or "ON" position.
- Rotate the power switch/volume control clockwise to turn on the CB radio. You will hear a click when the power comes on. At this time, the CB display and switch position indicators will light up and the channel indicator will appear on the display.

NOTE

- When the CB radio is turned off and then turned on again, memory in the CB radio will automatically return to the last channel selected.
- When the battery becomes discharged or is disconnected, the channel indicator is reset to "CHANNEL 1."

Operating the CB Radio:

- Turn the squelch control counterclockwise all the way.
- Select the desired channel.
- Turn the power switch/volume control clockwise a little. At this time, receiving signals or noise will be heard. When CB signals are being received, the receiving indicator appears on the display.
- Turn the squelch control clockwise until the noise is eliminated. You can receive CB signals through the speakers, or you can communicate through the "Ground Control" helmet sound system (Refer to the "INTERCOM" chapter).
- If you want to receive CB signals through the "Ground Control" helmet sound system only, push the helmet sound button. At this time, the helmet sound indicator appears on the radio/cassette display. Refer to the "INTERCOM" chapter.
- Adjust the CB volume to the desired sound level.
- With the rider talk switch and/or passenger talk switch turned on, transmit messages to the opposite CB station. At this time, the transmission indicator will appear on the display. Release both talk switches to activate the receiver.

NOTE

- You can receive CB transmissions and listen to the AM/FM stereo radio or cassette player at the same time.
- The AM/FM stereo radio or cassette player will be muted under the following conditions:
 - ☆ While the rider and passenger are communicating on the intercom (Refer to the "INTERCOM" chapter).
 - ☆ While either talk switch (rider or passenger) is turned on to transmit on the CB radio.
 - ☆ While CB signals are being received.

Switching off the CB Radio:

- Rotate the power switch/volume control counterclockwise until it clicks. At this time, the CB display illumination and switch position indicators will go out and the channel indicator on the display will disappear.
- Turn off the ignition switch.

INTERCOM

Features

- Rider and passenger can communicate while listening to the AM/FM stereo radio, cassette player, and/or CB radio.
- Muting level control

Intercom Controls

Control Unit:

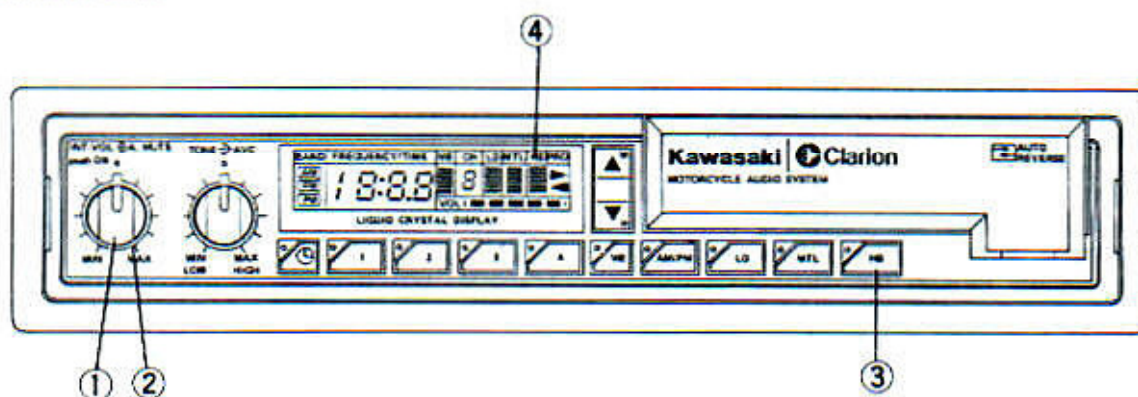

1. Intercom Volume Control
2. Muting Level Control
3. Helmet Sound Button
4. Helmet Sound Indicator

1. Intercom Volume Control

Rotate the intercom volume control clockwise to increase volume, or counterclockwise to decrease volume.

2. Muting Level Control

Rotate the muting level control to adjust for the speaking volume required to mute the sound from the AM/FM stereo radio or cassette player. Refer to the "How to Use the Intercom" section.

3. Helmet Sound Button

Push this button to listen to the AM/FM stereo radio, cassette player, and/or CB radio through the "Ground Control" helmet sound system only. Push this button again to listen from the speakers.

4. Helmet Sound Indicator

The helmet sound indicator appears on the display when the helmet sound button is pushed.

DIN Plugs:

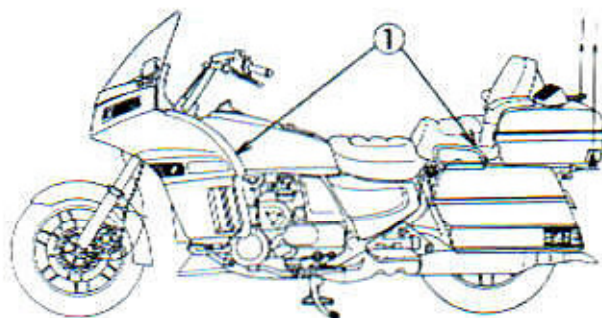

1. DIN Plugs

1. DIN Plugs

Two DIN plugs are provided for connecting the "Ground Control" helmet sound system.

How to Use the Intercom

WARNING

- **Carefully read the “GENERAL INSTRUCTIONS” chapter before using the intercom. Learn and observe all the rules.**
- **Connect the “Ground Control” helmet connecting cords to the DIN plugs for the rider and passenger.**
- **With the AM/FM stereo radio or cassette player switched on and/or the CB radio switched on, the rider and passenger can communicate through the “Ground Control” helmet sound system. If you want to use the intercom only, adjust the volume of the AM/FM stereo radio, cassette player, and/or CB radio to the minimum level.**
- **Adjust the intercom volume to the desired sound level while communicating with the passenger. Both the rider and passenger can communicate through the “Ground Control” helmet sound system and can listen to the AM/FM stereo radio, cassette player, and/or CB radio through the speakers.**
- **If you want to listen to the AM/FM stereo radio, cassette player, and/or CB radio through the “Ground Control” helmet sound system only, push the helmet sound button. At this time, the helmet sound indicator will appear on the display. Now, communication between the rider and passenger is mixed with the AM/FM stereo radio, cassette player, and/or CB radio sound.**
- **Turn the muting level control clockwise so that the AM/FM stereo radio, cassette player, and/or CB radio is muted by normal speaking but is not muted by ambient noise. With these settings, you can listen to the AM/FM stereo radio, cassette player, and/or CB radio while communicating through the “Ground Control” helmet sound system.**

NOTE

- *When the AM/FM stereo radio, cassette player, and/or CB radio is muted by environmental noise, turn the muting level control counter-clockwise and/or decrease the intercom volume.*

MAINTENANCE

Cleaning the Motorcycle

Cleaning Notes

CAUTION

- Be sure to keep the tape slot door closed to prevent water and dirt from entering and damaging the radio and cassette player.



1. Tape Slot Door

- Avoid spraying water with great force near the audio components. Cover the AM/FM radio and cassette player with the provided dust cover.

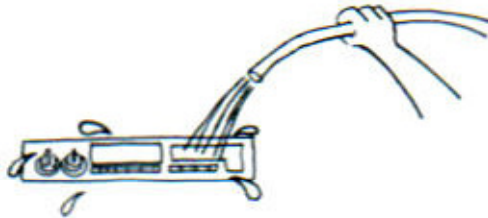

- To prevent surface damage, do not clean plastic parts with organic solutions such as gasoline, thinner, or benzine. Use a soft cloth which has been soaked in a solution of neutral detergent to clean plastic parts, then dry them with a soft cloth.

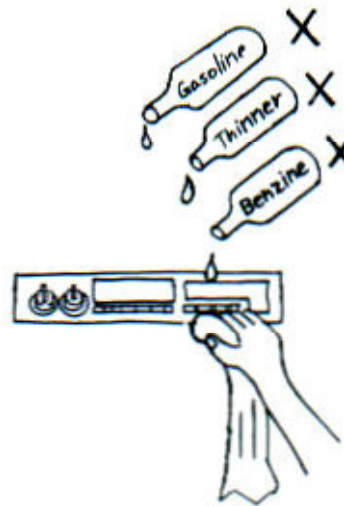

Cassette Player

Cleaning

After the player is used for a long time, tape residue and dust tend to build up on the head and tape path. A dirty head will reduce the overall efficiency of the head, and poor or distorted sound may occur. Also, a dirty pinch roller or capstan could cause erratic tape movement or jamming. To prevent these problems and insure longer life for your cassette player and tapes, clean the head, pinch rollers and capstans from time to time with a cotton swab slightly moistened with alcohol.

ZG1200



KAWASAKI HEAVY INDUSTRIES, LTD.
Consumer Products & Machinery Group

Part No. 99920-1398-12

Printed in Japan