

Kawasaki Audio Systems Troubleshooting Manual

FOREWORD

Please read the Kawasaki Voyager Audio Systems Operator's Manual so that you completely understand the operation of all components.

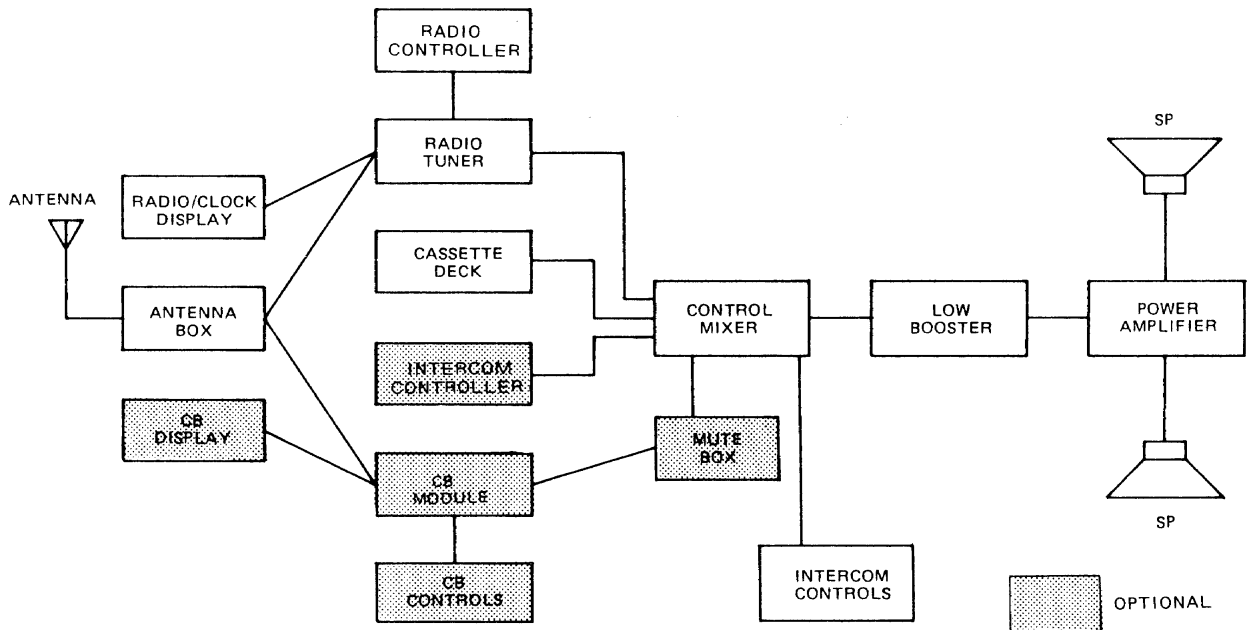

The Kawasaki Voyager Audio System consists of many components. Follow the troubleshooting flow charts carefully so that only the faulty component is replaced. Sometimes a customer may be confused with a "problem" in AM or FM reception when actually the radio is functioning properly. Be sure to review the Radio Characteristics section with the customer so that AM and FM reception performance and causes of interference are fully understood.

Safety Awareness

Whenever you see the symbols shown below, heed their instructions! Always follow safe operating and maintenance practices.

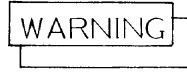

- o This warning symbol identifies special instructions or procedures which, if not correctly followed, could result in personal injury or loss of life.



- o This caution symbol identifies special instructions or procedures which, if not strictly observed, could result in equipment damage or destruction.

NOTE:

- o Indicates points of particular interest for more efficient and convenient operation.

Table of Contents

RADIO CHARACTERISTICS

Motorcycle Radio vs. Home Stereo

AM Signals

Service Area

Station Mixing

Interference

FM Signals

Service Area

Station Flutter

Fading

Station Jumping

Multipath

Interference

SASC Feature

SUPER SASC Feature

TROUBLESHOOTING

Before you Begin

Quick Fuse Failure Analysis

No Sound Flow Chart Directory

No Sound From Any Unit

No Sound From Radio Only

No Sound From Cassette Only

No Sound From CB Only

Poor Radio Reception

Cassette: Poor Tone or Eating Tapes

CB Difficulty

Handle Switch Difficulty (Auto Seek Tuning, Muting)

Handle Switch Difficulty (CB Channel Select Switch)

Display Difficulty (Radio, Clock)

Display Difficulty (CB)

Clock Difficulty

Intercom Difficulty

- Test #1 Power Circuit From Battery to Control Mixer and Power Amplifier Test
- Test #2 Power to Cassette Deck
- Test #3 Speaker Test
- Test #4 Radio Tuner Bypass Test
- Test #5 Cassette Deck Bypass Test
- Test #6 Low Booster Bypass Test
- Test #7 Control Mixer Switching Test
- Test #8 Radio Controller Test
- Test #9 Cassette Motor Operation Test
- Test #10 Power Distribution to CB Module Test
- Test #11 Mute Box Bypass Test
- Test #12 Antenna Connection Test
- Test #13 Antenna Box Bypass Test
- Test #14 CB Antenna Adjustment
- Test #15 Handle Switch Test
- Test #16 Radio Display Test
- Test #17 CB Display Test
- Test #18 Intercom Controller Test
- Test #19 CB Controller Test
- Test #20 Speaker Switch Test
- Test #21 Helmet Sound System (and Branch Lead) Test
- Test #22 Handle Switch Test (CB)
- Test #23 Mute Box Bypass Test
 - Attachment (I) Wiring and Connector Identification
 - Attachment (II) Wiring Diagrams (Standard)
 - Attachment (III) Wiring Diagrams (Includes All Optional Units)
 - Attachment (IV) Audio System Operation

RADIO CHARACTERISTICS

Motorcycle radio receivers are more sophisticated than other receivers, so it will be beneficial to assist the consumer in understanding wave propagation. Radios can be divided into AM (Amplitude Modulation) and FM (Frequency Modulation). Radio signals and reception are affected by certain factors, including atmospheric conditions, strength of radio station signals, physical location of motorcycle electrical accessories on motorcycle, etc. Understanding these limitations, will help you minimize these conditions.



MOTORCYCLE RADIO vs. HOME STEREO

The radio in a moving vehicle has more difficulty with reception, especially with FM, than a home receiver with a fixed antenna, often located high on the roof. Not only is the motorcycle's antenna relatively short and a compromise in design between the best for AM and FM, but the incoming signal is subject to changes in direction, strength and interference conditions as the vehicle moves. Three kinds of problems are most often encountered in moving vehicles. They are strong signal interference, skip noise (due to weak signal) and multipath noise.

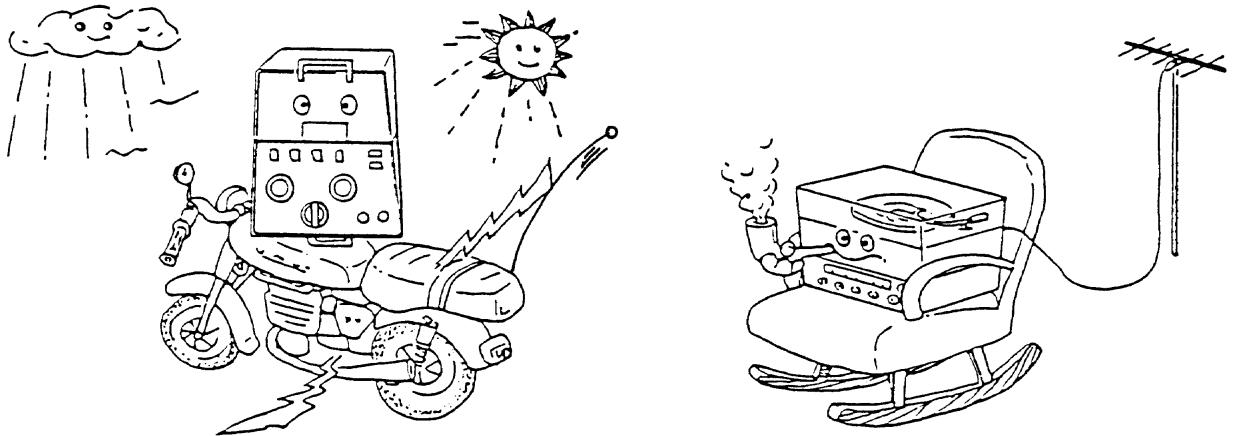

AM SIGNALS

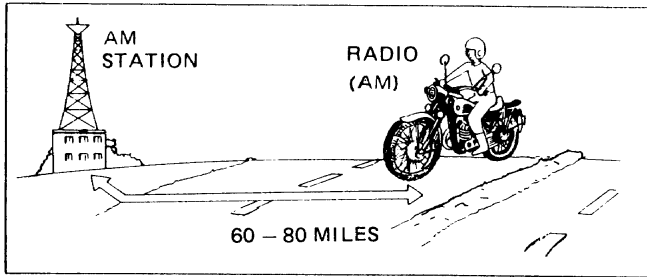

SERVICE AREA

Beyond a distance of 60 to 80 miles from an AM station, the station signal weakens. This causes station mixing and interference on the radio.

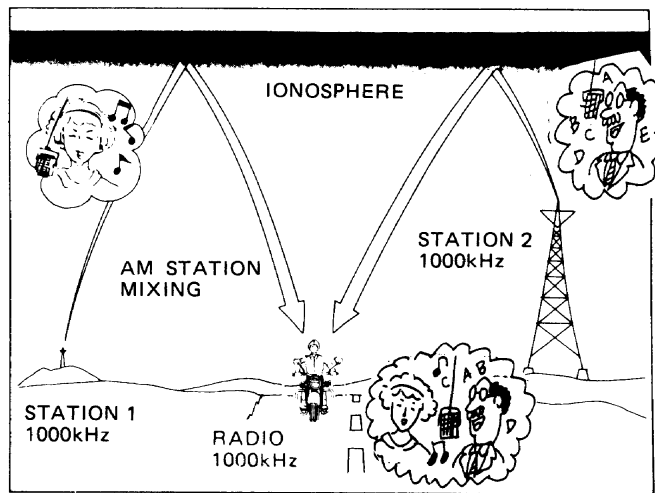

STATION MIXING

AM waves bend around objects such as buildings or mountains, and bounce off the ionosphere. Because of this, two stations might be picked up on the same frequency at night. This is called Station Mixing.

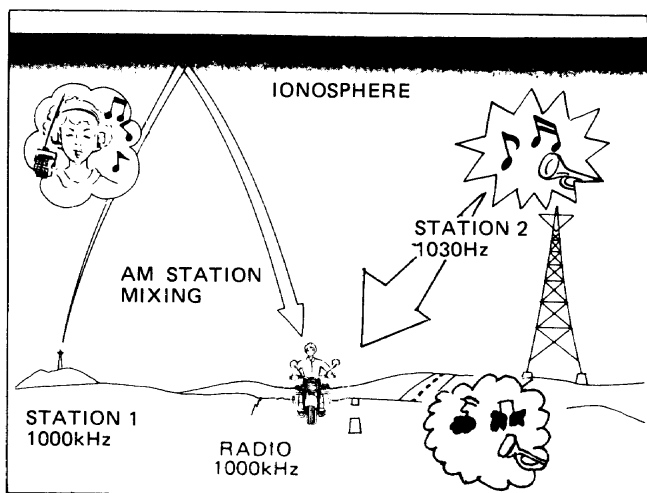

INTERFERENCE

When an adjacent station has a very strong signal, annoying noises may occur while receiving a weaker station. In the worst cases, the adjacent station may interfere. **THIS IS NOT RECEIVER TROUBLE.** This is caused by particular wave conditions.

FM SIGNALS

Since stereo FM is a two channel system it has a fuller sound than monaural FM, and a more complex signal. This means the reception range of stereo FM is usually shorter, and reception problems are more apt to occur.

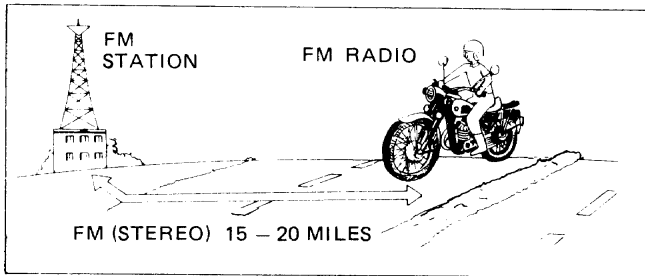

SERVICE AREA

Beyond a distance of 15 to 20 miles FM stations may fade out completely or fade in and out. When driving in weak signal areas, such as hills, valleys, tunnels, etc., unusual noise interference may occur.

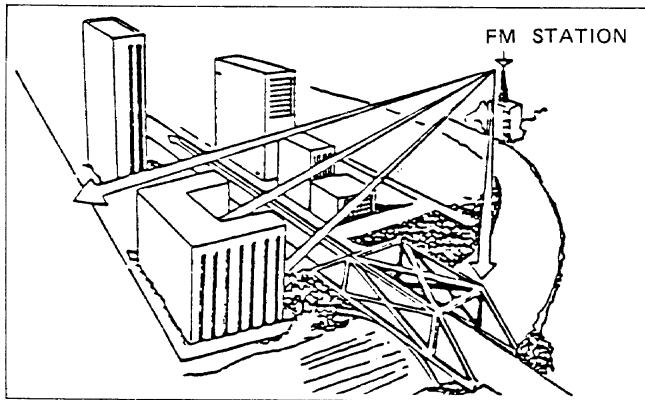

STATION FLUTTER

FM signals are easily reflected by solid objects. Therefore FM signals are blocked by tall buildings or other obstructions. This is called a flutter area, and results in POPS AND HISSES in the radio.

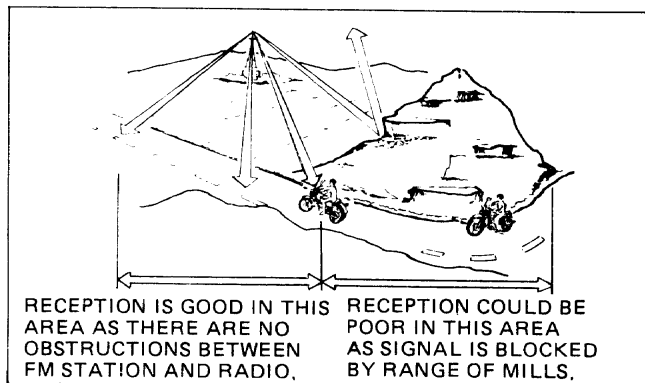

FADING

Since FM signals are easily reflected by solid objects, it is possible for an area to be blocked from the FM station. Fading occurs when an object blocks the path between the FM station and radio.

STATION JUMPING (STATION SWAPPING)

FM has a special characteristic called station jumping. This occurs when the frequency of two stations are near each other and a tall building temporarily blocks the desired signals. The Automatic Frequency Control in the radio tunes to the adjacent station until the desired signal returns.

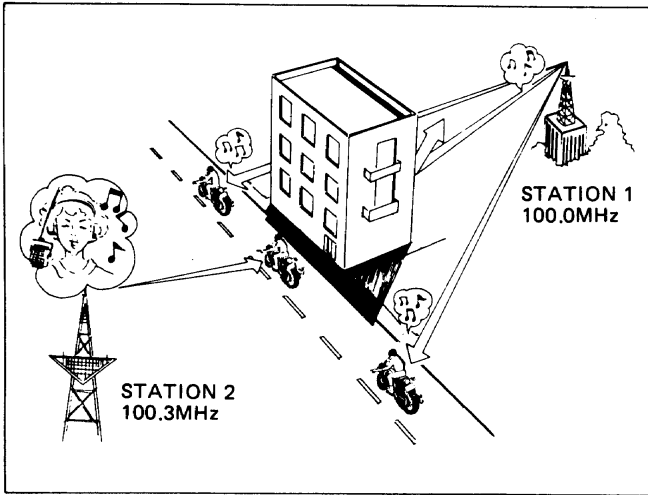

MULTIPATH

Because of the reflecting characteristics of FM signals, like light, direct and reflected signals may reach the motorcycle antenna at the same time, which is called "The multipath effect". Sometimes the direct and reflected signals cancel each other out, causing dead spots. As the motorcycle moves through these spots, the listener will hear a fluctuation of sound. These are the same characteristics as so called "Ghost" images on a TV screen when reflection of TV waves occur.

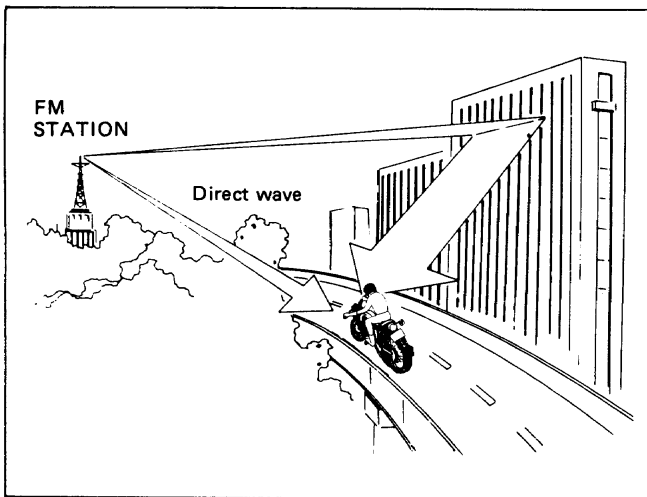

INTERFERENCE

When an adjacent station has a very strong signal, annoying noises may occur while receiving a weaker station. In the worst cases, the adjacent station may interfere.

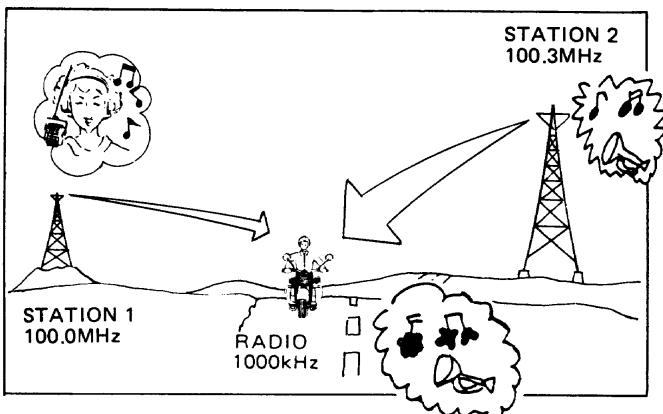

SASC FEATURE

The Kawasaki motorcycle radio has a signal actuated stereo control (SASC) feature. When listening to a stereo station and the station signal becomes weak, you will get static and interference. If this should happen, the SASC will automatically switch from stereo to monaural, thereby eliminating or reducing the static and interference. When the station signal becomes stronger, the SASC will automatically switch from monaural back to stereo. When the SASC switches back and forth from stereo to monaural, the stereo light on the radio will go on and off accordingly. This is not a malfunction, but is an indication that the SASC is functioning properly, as it was designed to do.

The SASC circuit extends the listenable service range by about 20%.

SUPER SASC FEATURE

SUPER SASC is the latest circuit developed by Clarion to reduce annoying multipath distortion in addition to the SASC which improves weak signal reception.

SUPER SASC continuously monitors "multipath distortion" and eliminates unacceptable noise automatically by reducing high frequency response.

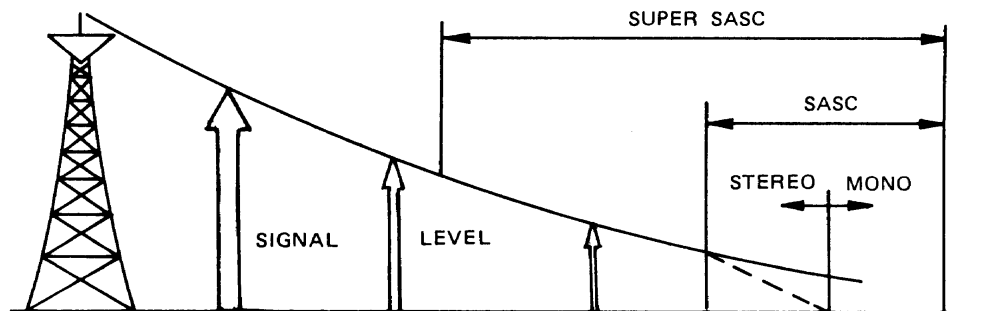

TROUBLESHOOTING

BEFORE YOU BEGIN

- Refer to the Audio System Operation Checklist at the back of this manual (page 15).
- Did you read the Radio Characteristics section? You and your customer must understand normal reception characteristics and limitations. Remember, that radio signals and reception can be affected by atmospheric conditions, strength of radio station signals, physical location of the motorcycle, electrical accessories on the motorcycle, etc.
- Check that the battery is fully charged.
- Always use the recommended resistor spark plugs to decrease static.
- Check that the antenna is not grounded if all radio (AM, FM and CB) reception is poor.
- Check all connectors. They must be tight, clean and dry.

NOTE:

All suggested numbers of measurement should be read with tolerance of 15%.
For example, Voltage 12 Volts ($12V \pm 15\% = 10.2V - 13.8V$)

NOTE:

When applying the tests shown in the back of this manual, disconnect and reconnect only the wire connectors specified.
Leave other component wiring in place.

QUICK FUSE FAILURE ANALYSIS

The Voyager audio system components use a total of seven fuses. The symptoms associated with fuse failure are described in the table below. The two illustrations on the following page show fuse location. The same fuse reference numbers are used in the table and both illustrations for easy identification.

No.	Fuse	System Conditions when Failed	
①	4-amp, black lead to power amp	Speakers All others	No OK
②	1-amp blue lead to control mixer	CBTX, Intercom All others	No OK
③	2-amp, blue lead to cassette	Cassette All others	No OK
④	3-amp, blue lead to CB	CB (all) All others	No OK
⑤	1-amp, red lead to CB	CBTX Scan	No memory Partial
⑥	1-amp, red lead to clock and radio memory	Clock AM FM	1:00 530, 610 1000, 1400 87.9 Preset memory
⑦	2-amp, blue lead to radio tuner	Radio Intercom CB Cassette	No OK OK OK

When fuses are found like those in drawing (4), replacing them may solve the problem. Fuses blown as shown in drawing (1), (2), or (3) usually indicate a large current drain caused by a short.

1) Black spot in the tube.

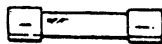

2) White spot in the tube.

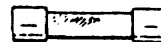

3) Cracks in the tube and the tips of the fuse melted.

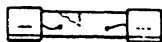

4) The tube loosened or the fuse inside broken by being pulled.

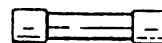

Before replacing a blown fuse, always check the amperage in the affected circuit. If the amperage is equal to or greater than the fuse rating, check the wiring and related components for a short circuit.

CAUTION

When replacing a fuse, be sure the new fuse matches the specified fuse rating for that circuit. Installation of a fuse with a higher rating may cause damage to wiring and components.

ONLY POWER LINES SHOWN

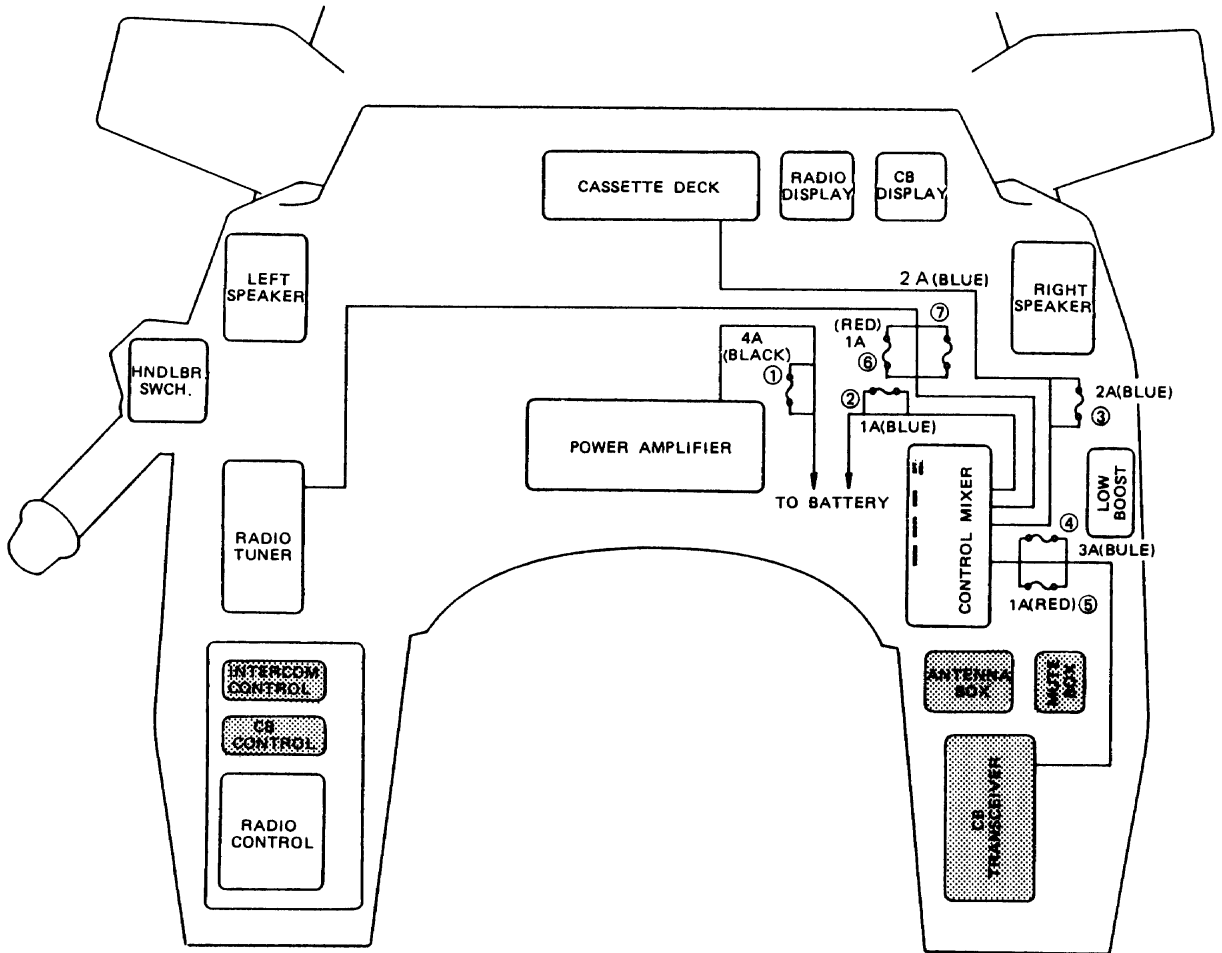

NOTE:
ALL FUSES ARE LOCATED BEHIND
THE RIGHT FRONT TURN SIGNAL.

 OPTIONAL UNIT

WIRING DIAGRAM (STANDARD)

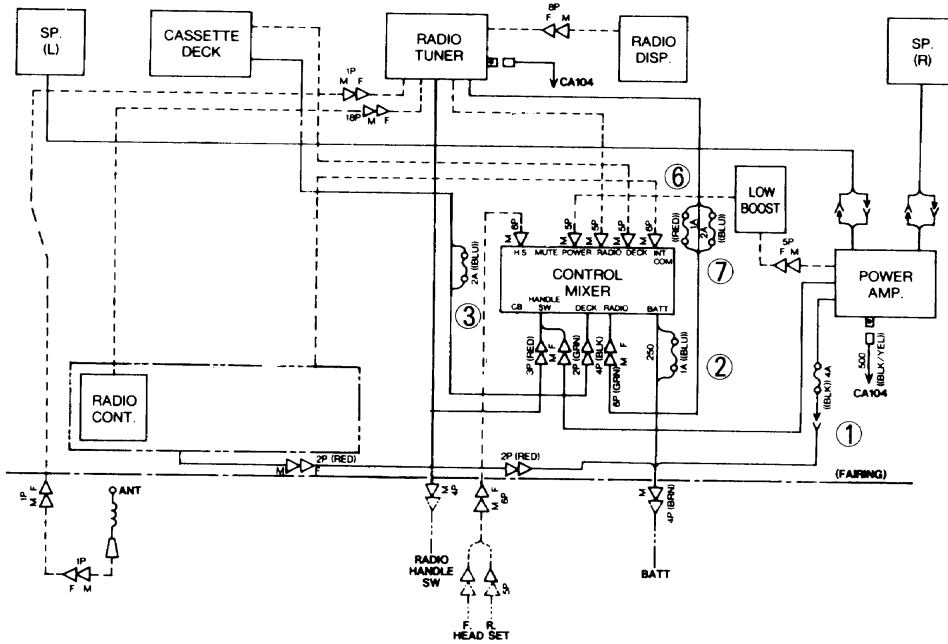

1	ORP	Channel up
2	GRN	Channel earth
3		
4	GRN	Prestalk earth
5	WHT	Prestalk
6	GRY	Channel down

1	ORP	Auto seek
2	GRN/YEL	Auto seek earth
3	GRY/BLK	Mute earth
4	BLU/WHT	Mute

1	BLK	Power supply (DC 12V)
2	BLK/YEL	Earth (Power amp.)
3	BLK/WHT	Power supply
4	RED/WHT	Power supply (DC 12V) (Back up)

1	YEL	Speaker select
2	GRY	Earth

WIRING DIAGRAM (INCLUDE ALL OPERATIONAL UNITS)

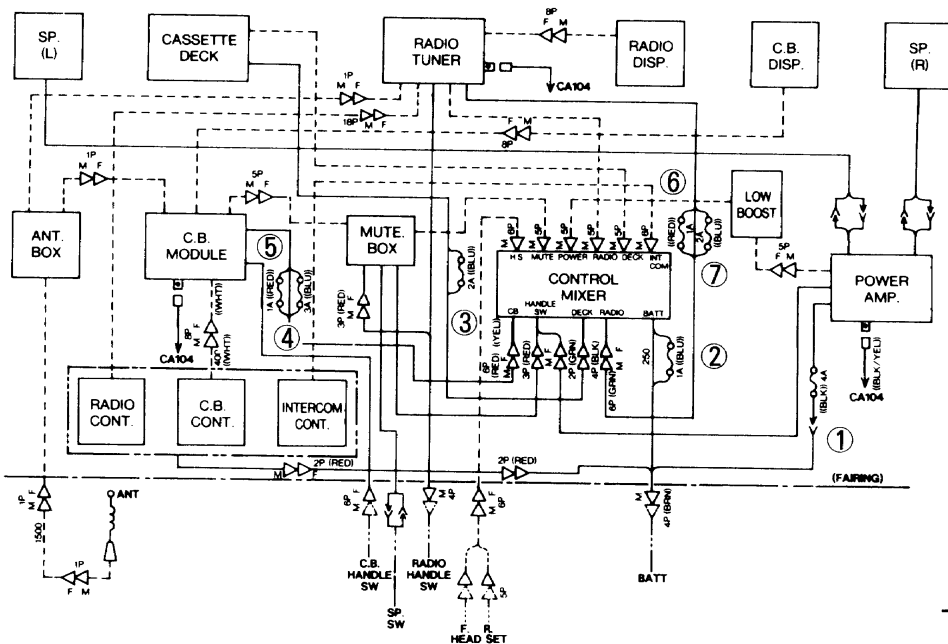

— POWER LINE
 - - - SIGNAL LINE

① ~ ⑦ = 12 VOLTS

NO SOUND
FLOW CHART DIRECTORY

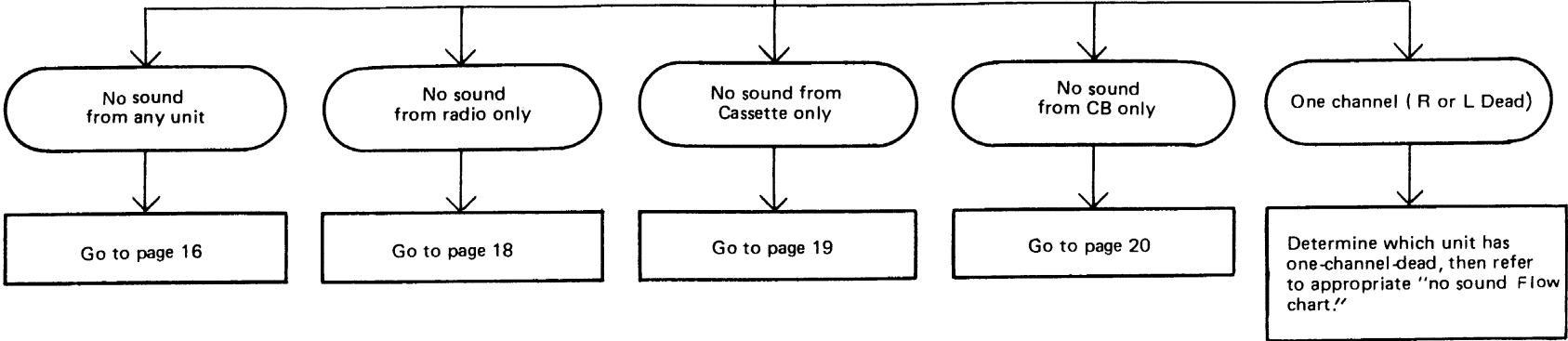

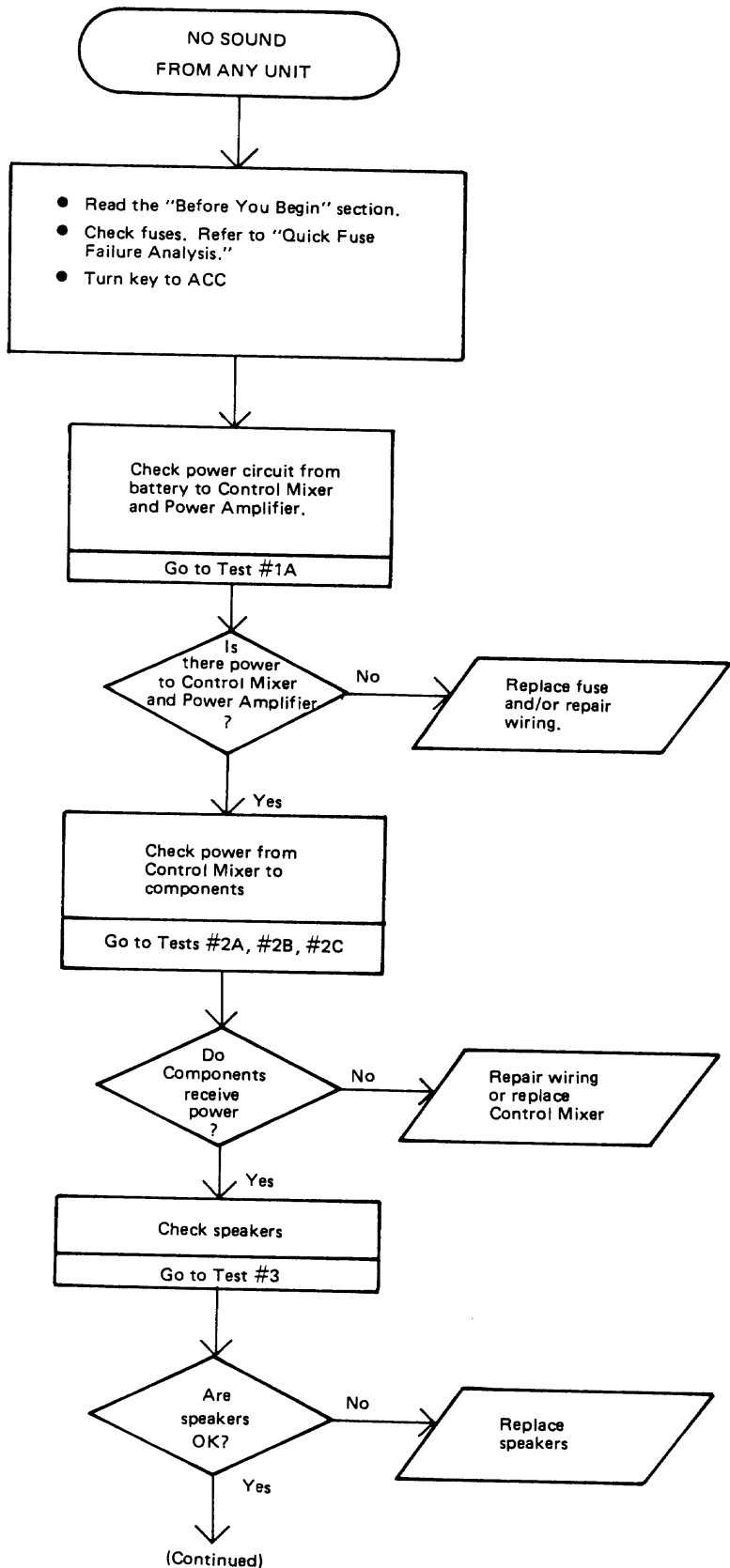

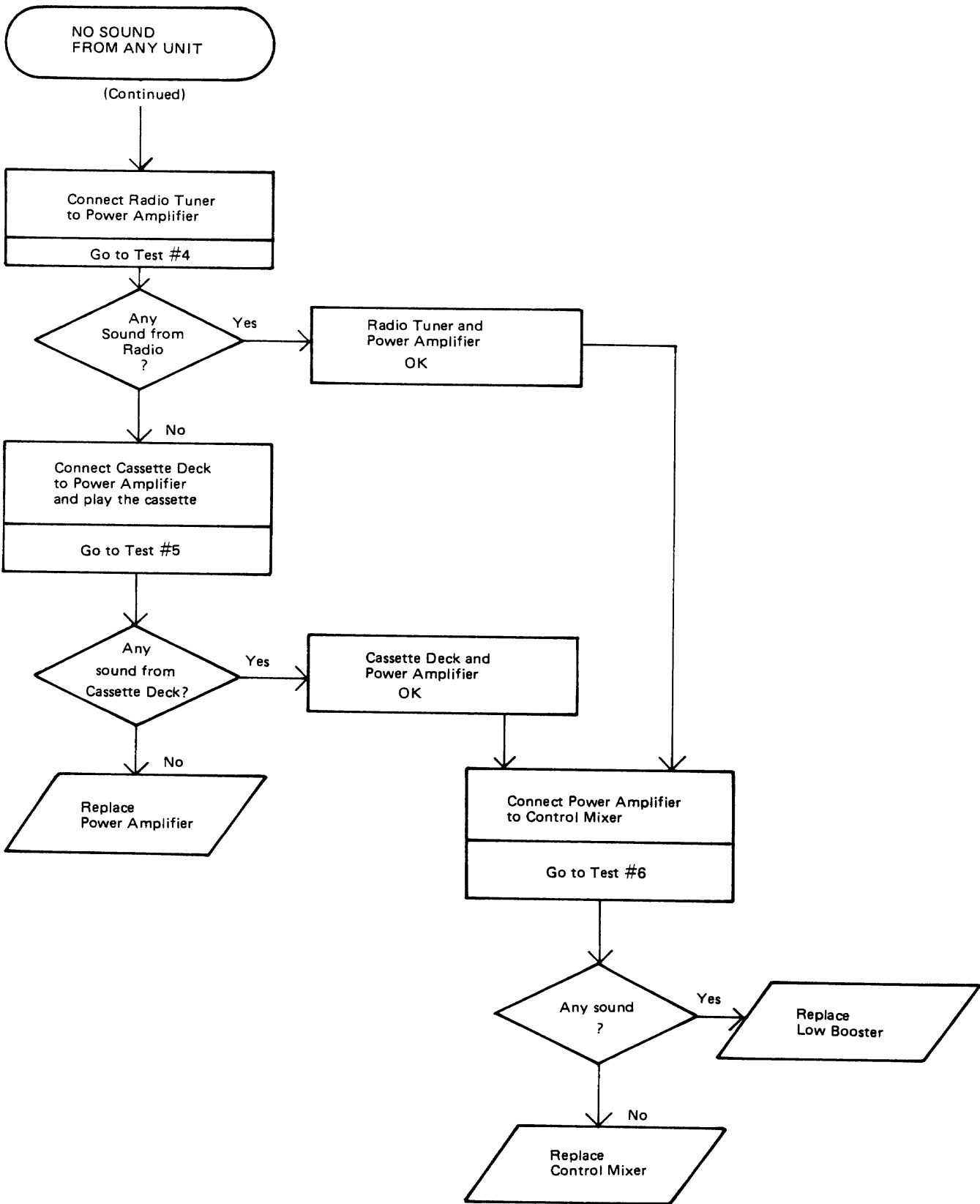

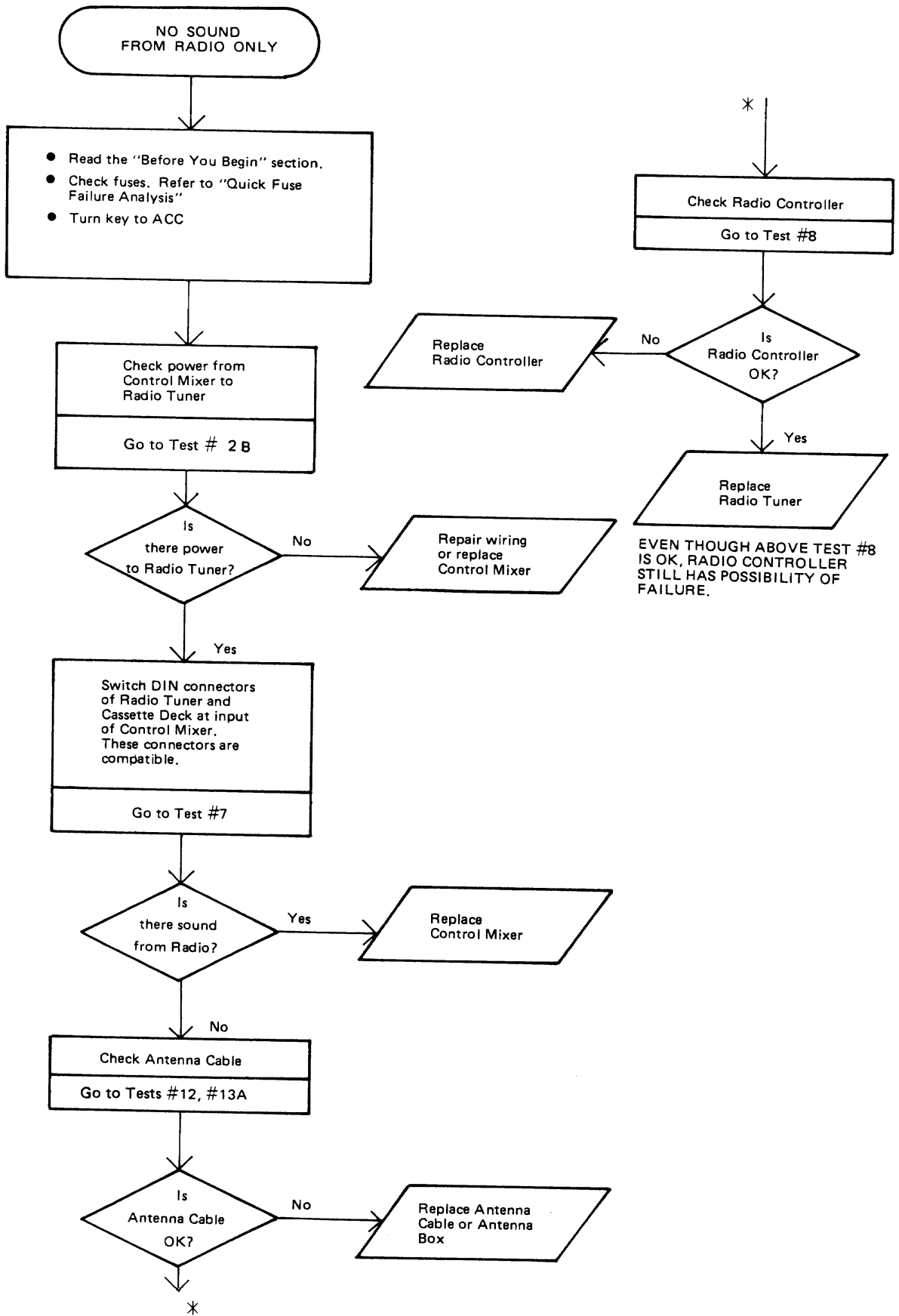

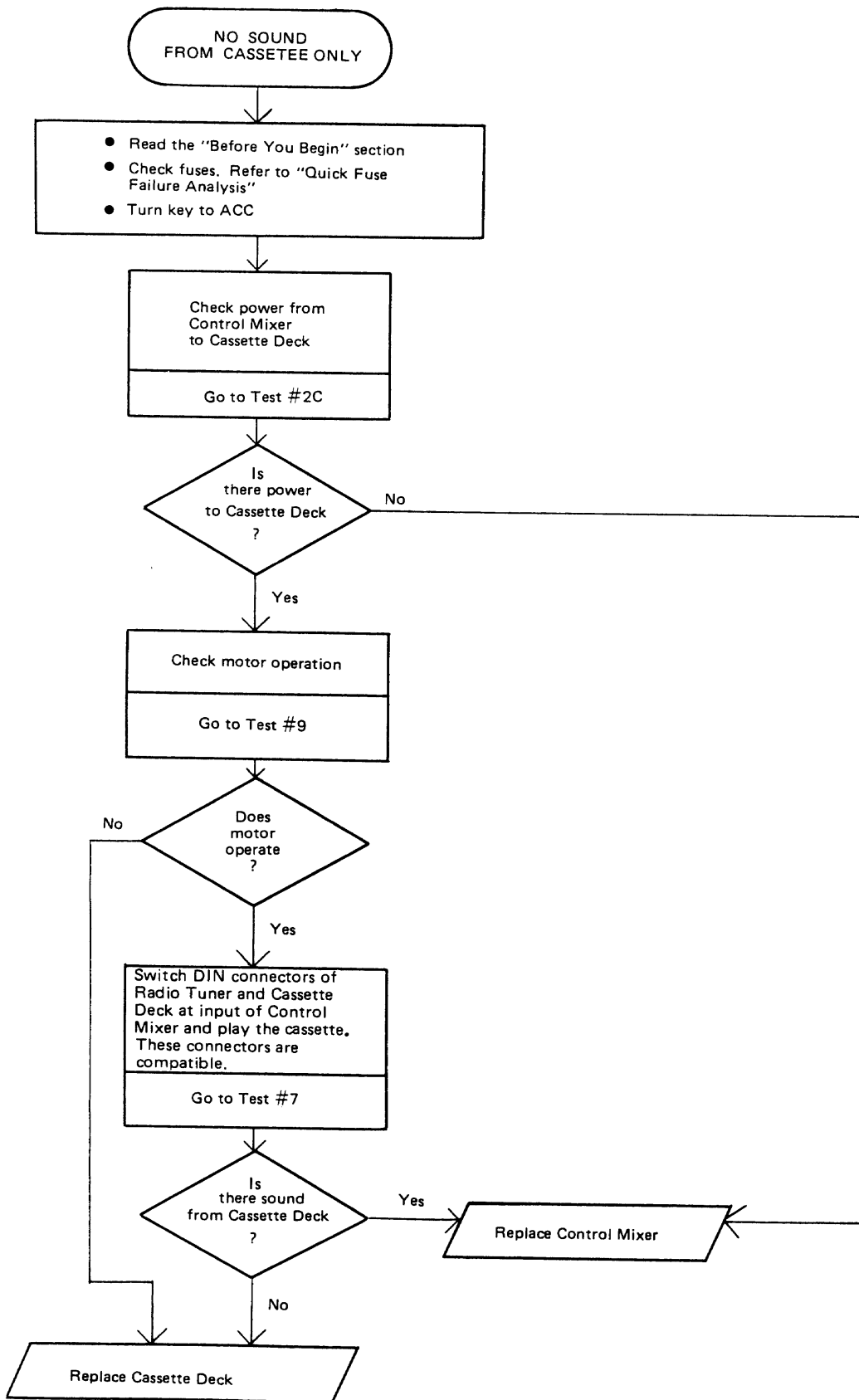

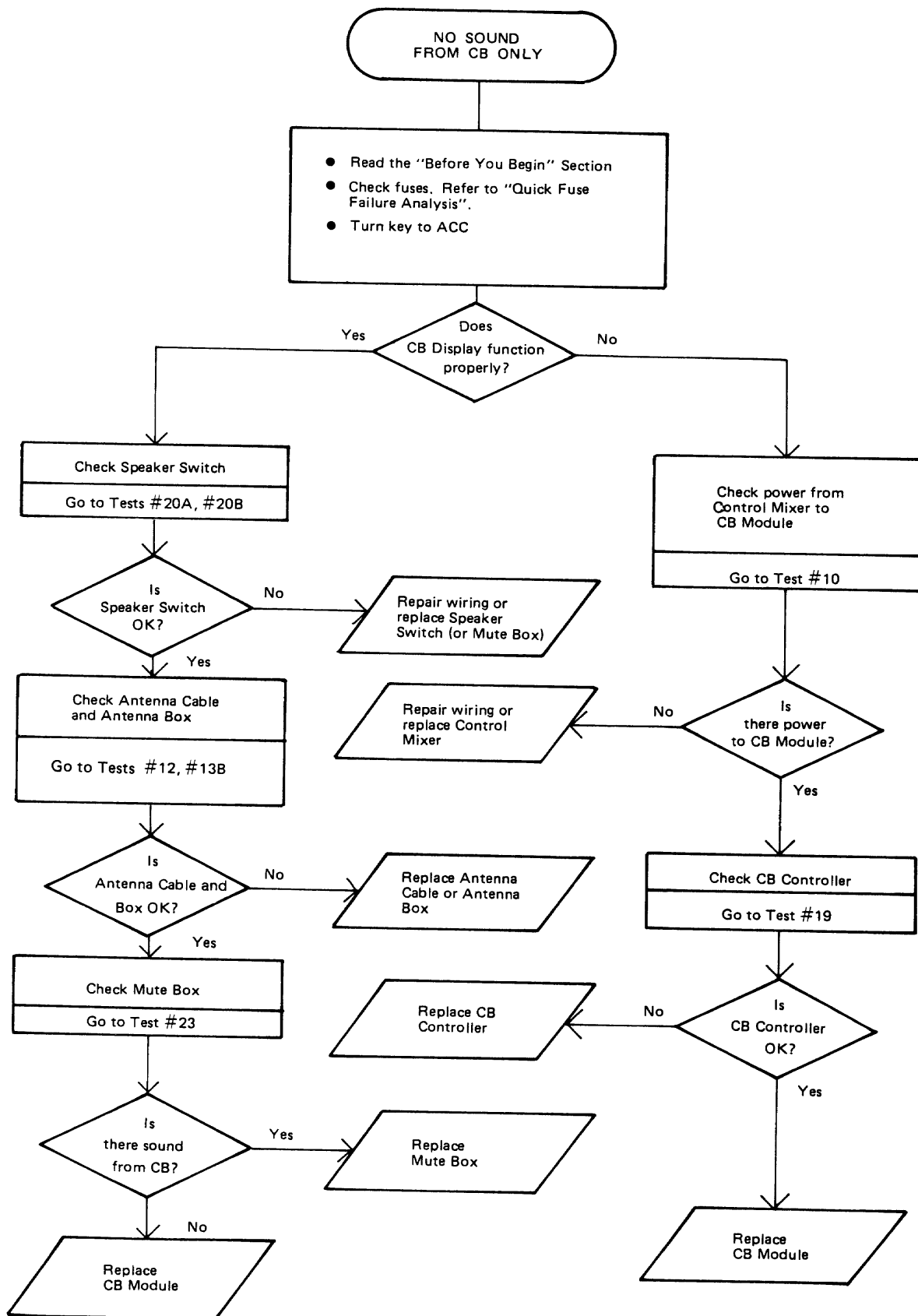

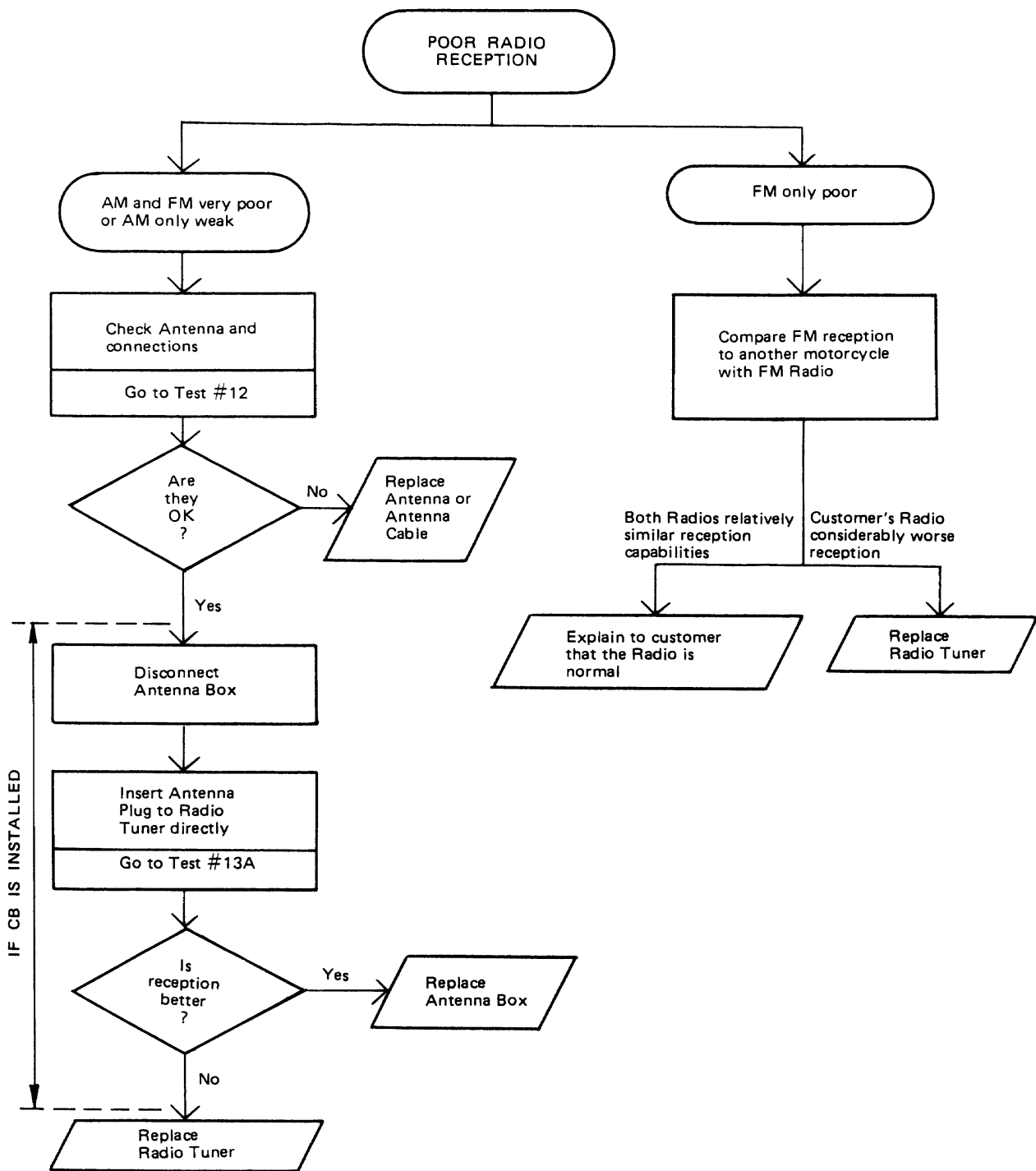

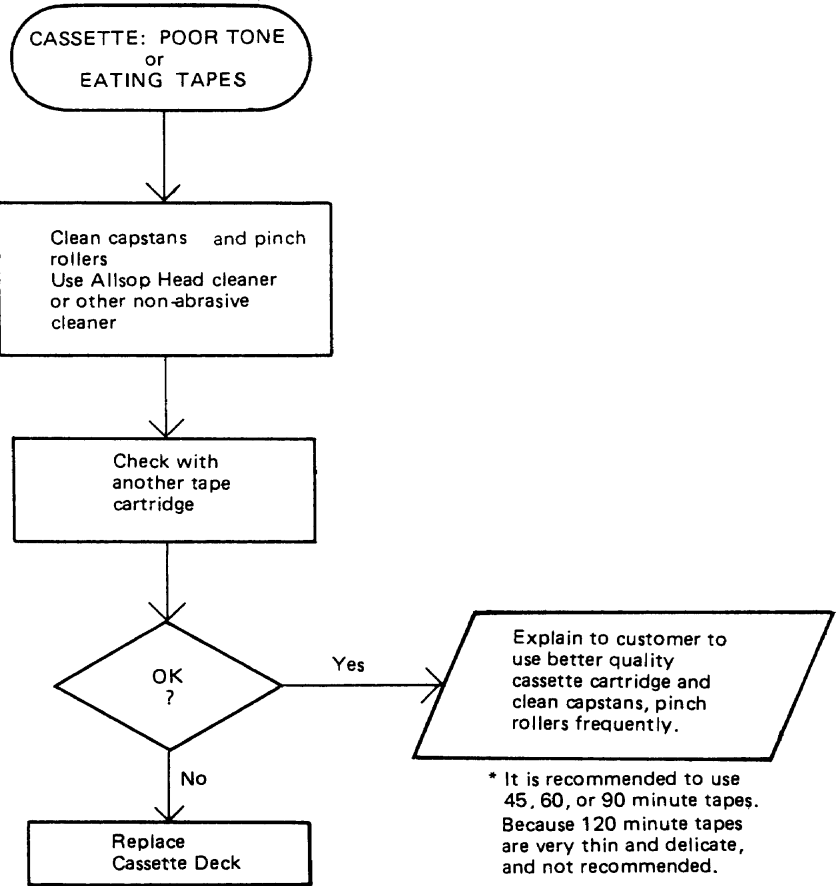

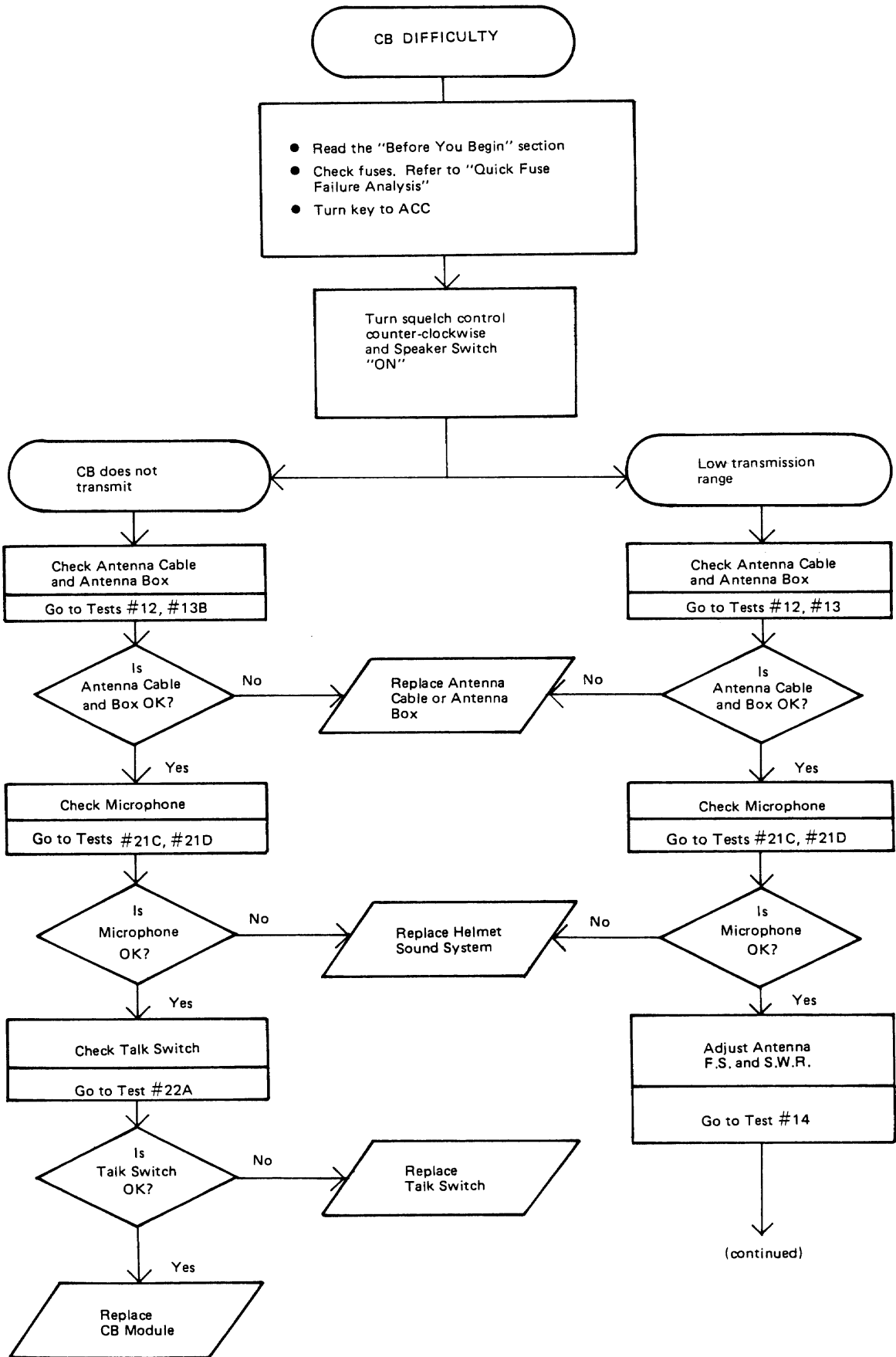

CB DIFFICULTY

(Continued)

Compare CB transmission range with another motorcycle CB

Customer's CB considerably worse

Replace CB Module

Both CB transmission ranges are almost the same

Explain to customer that CB is normal

HANDLE SWITCH DIFFICULTY
(AUTO SEEK TUNING, MUTING)

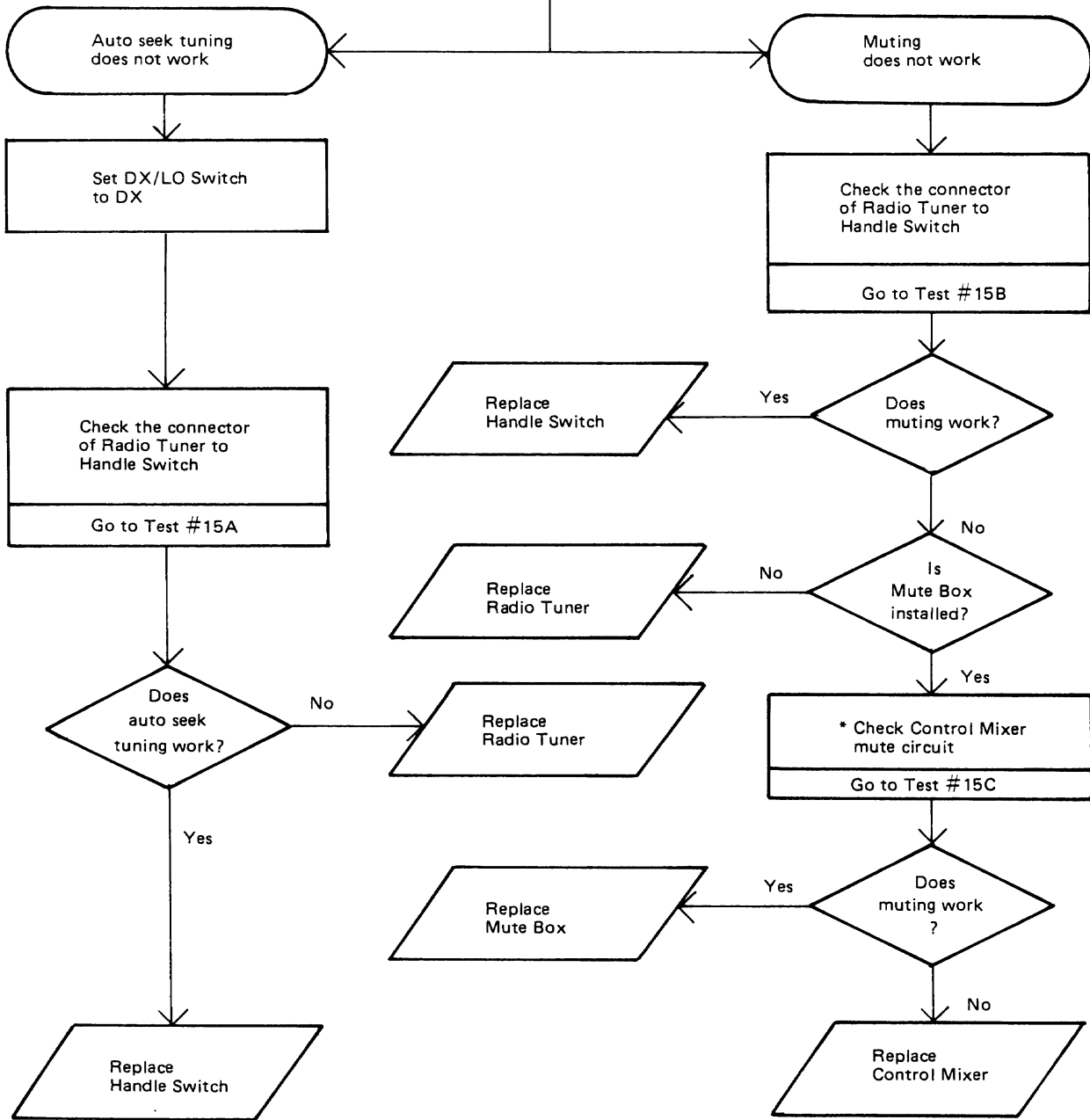

NOTE:
DX/LO Switch only operates
during Auto Seek Tuning and
does not affect radio reception.

* Mute circuit is also included
in Control Mixer

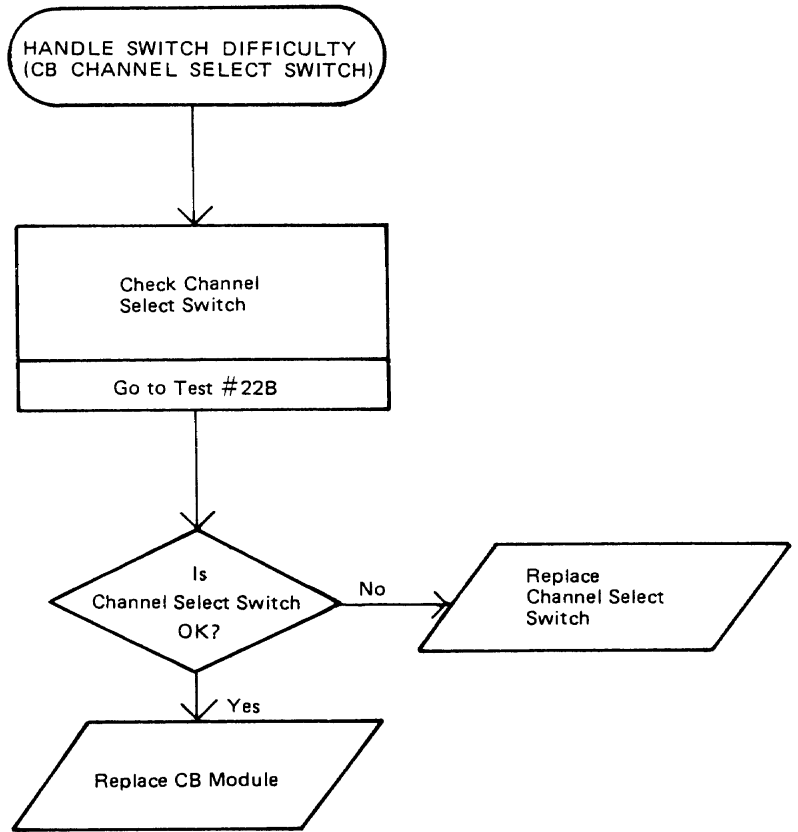

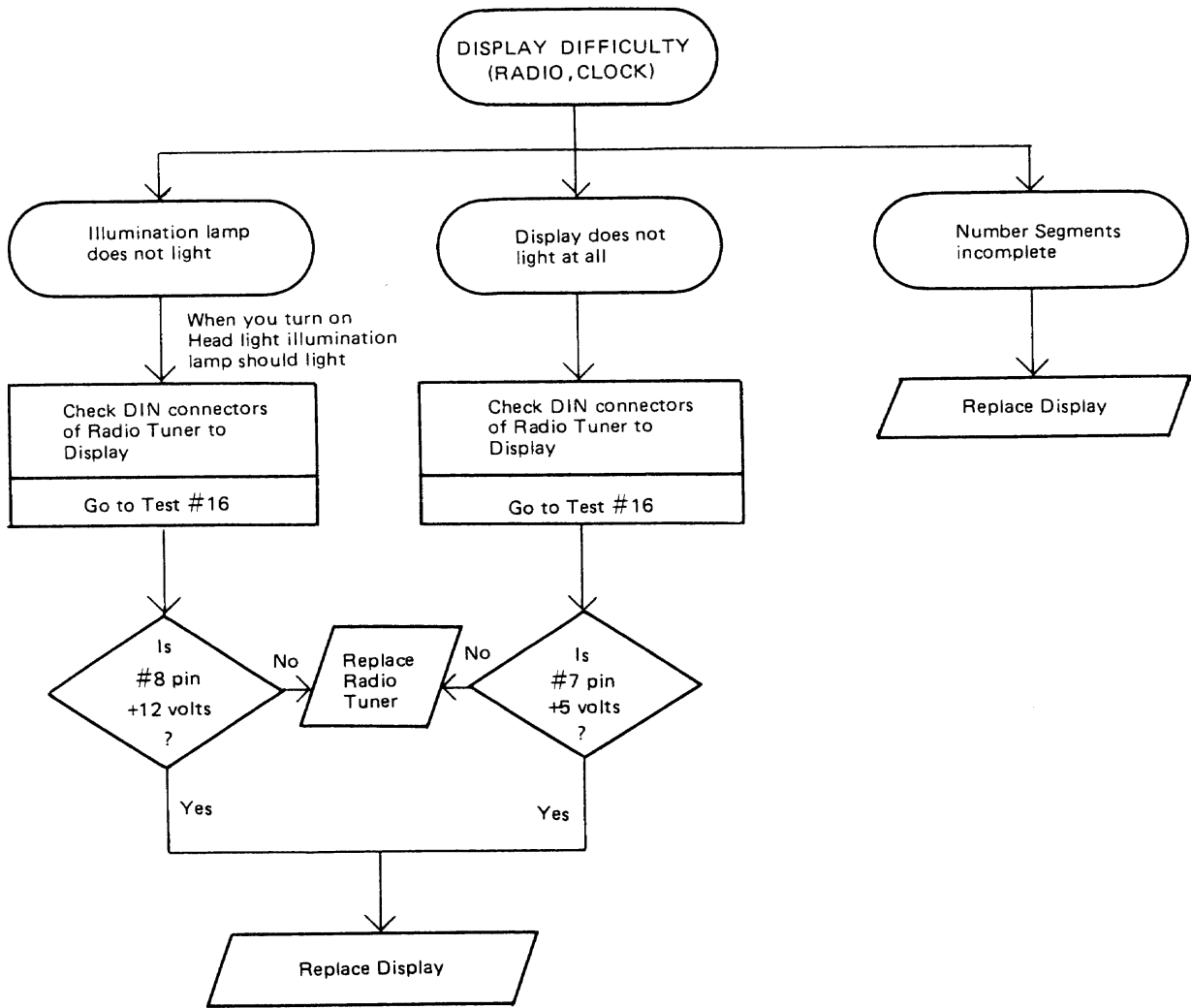

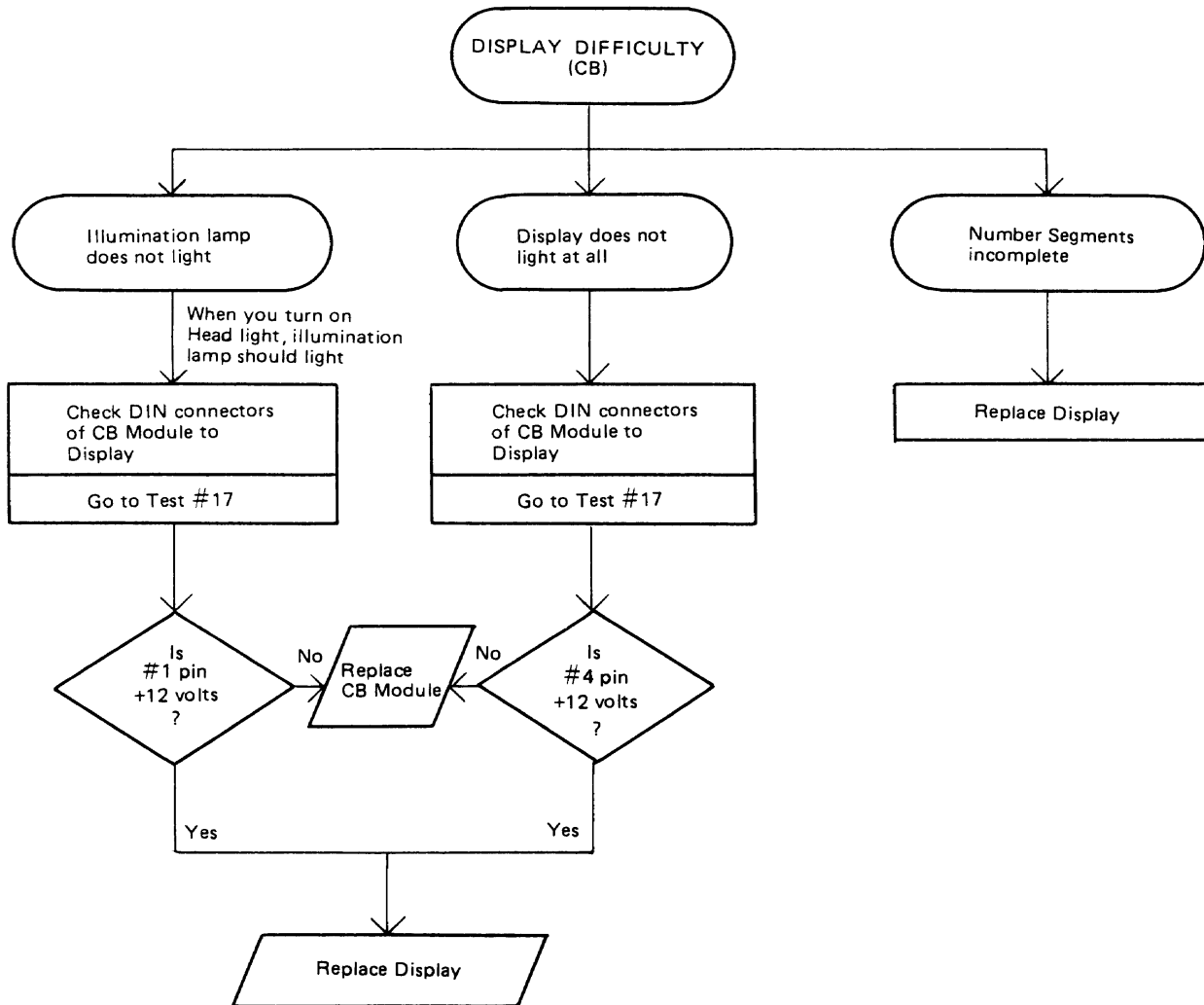

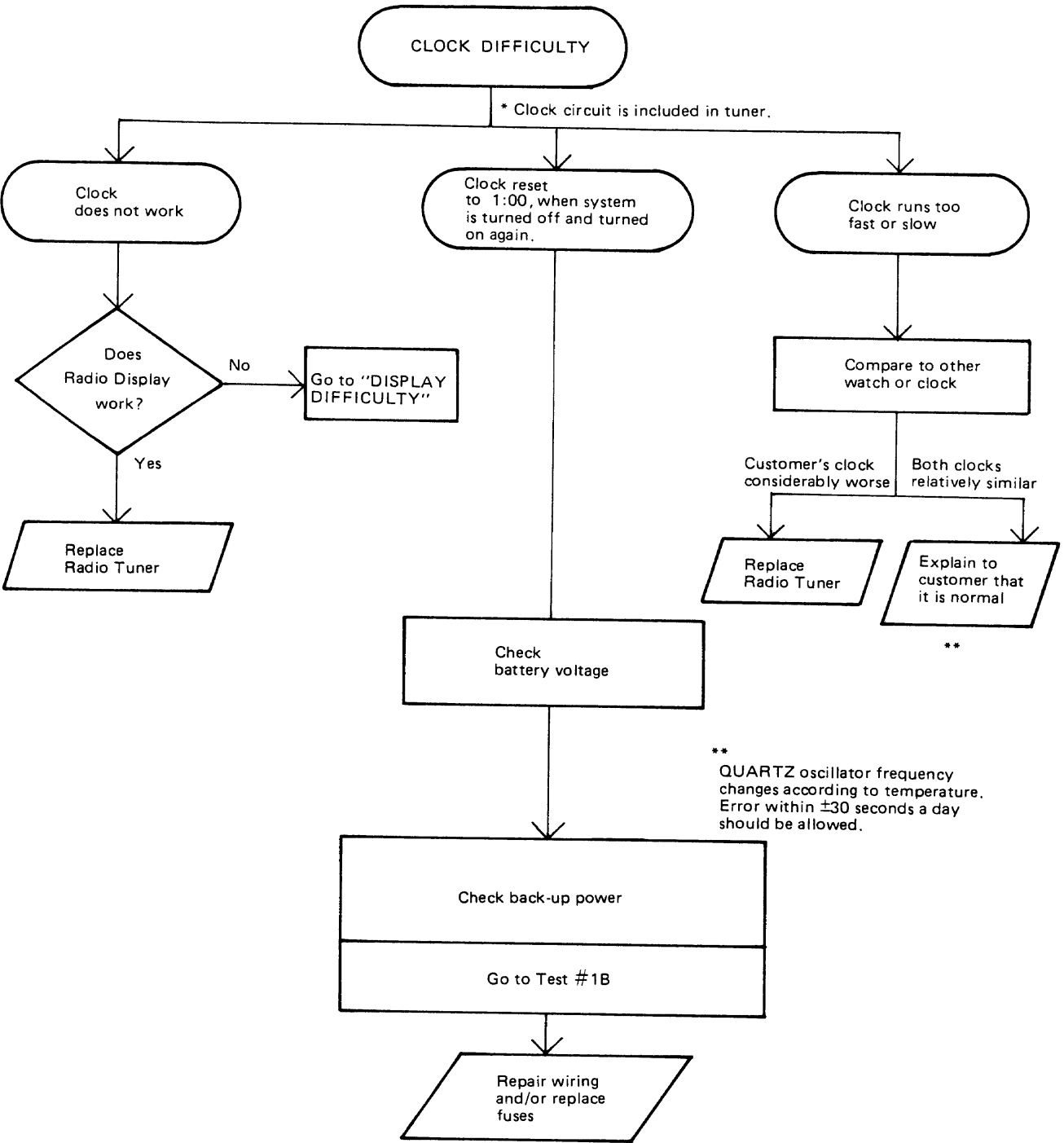

** QUARTZ oscillator frequency changes according to temperature. Error within ± 30 seconds a day should be allowed.

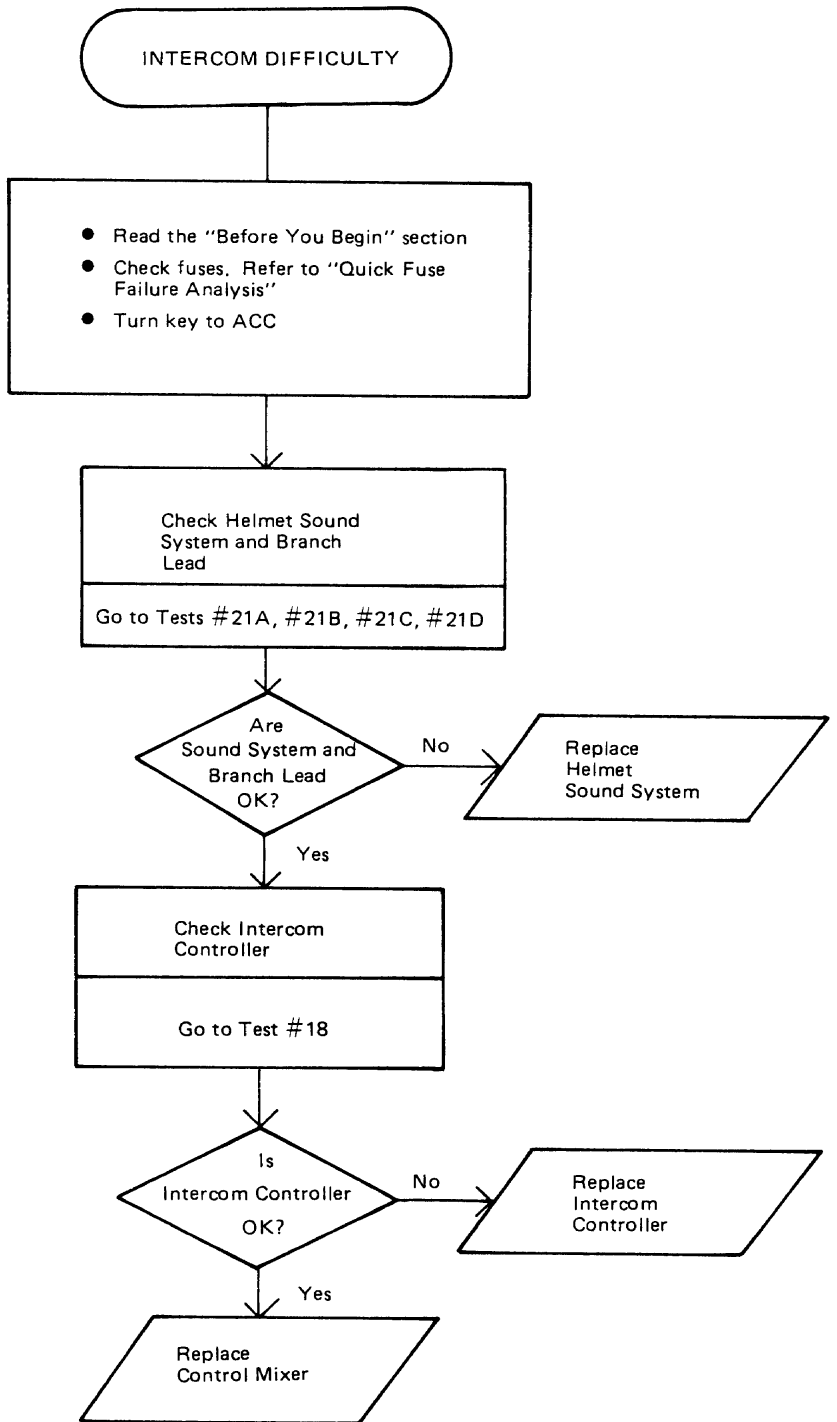

TEST #1 POWER CIRCUIT FROM BATTERY TO CONTROL MIXER AND POWER AMPLIFIER TEST

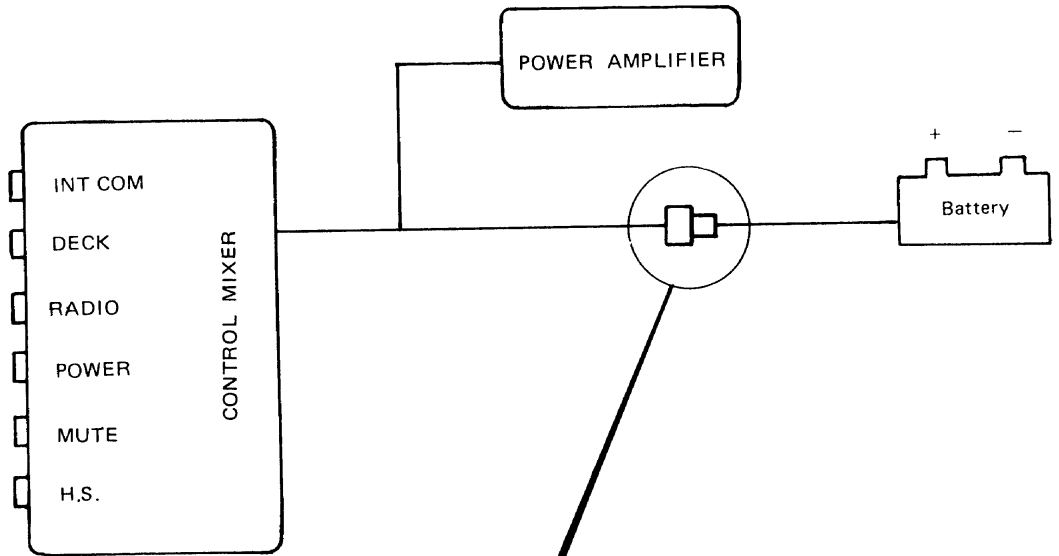

TEST #1A MAIN POWER TEST

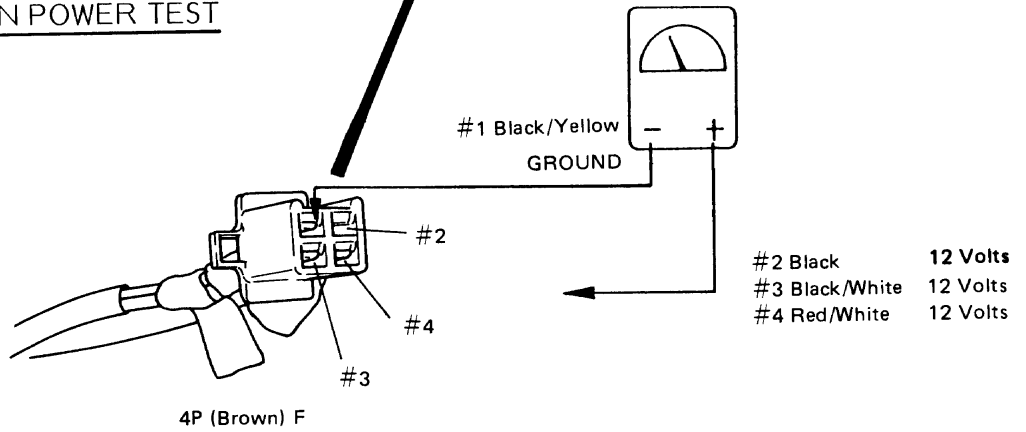

TEST #1B BACK UP POWER TEST

-TURN OFF KEY

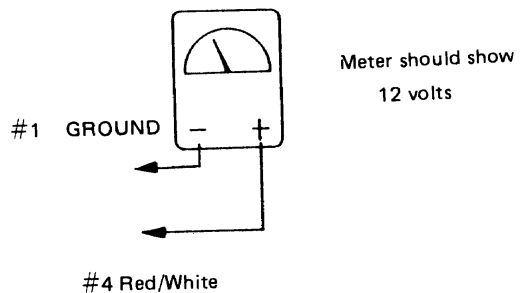

TEST #2 CONTROL MIXER POWER DISTRIBUTION TEST

TEST #2A POWER TO POWER AMPLIFIER

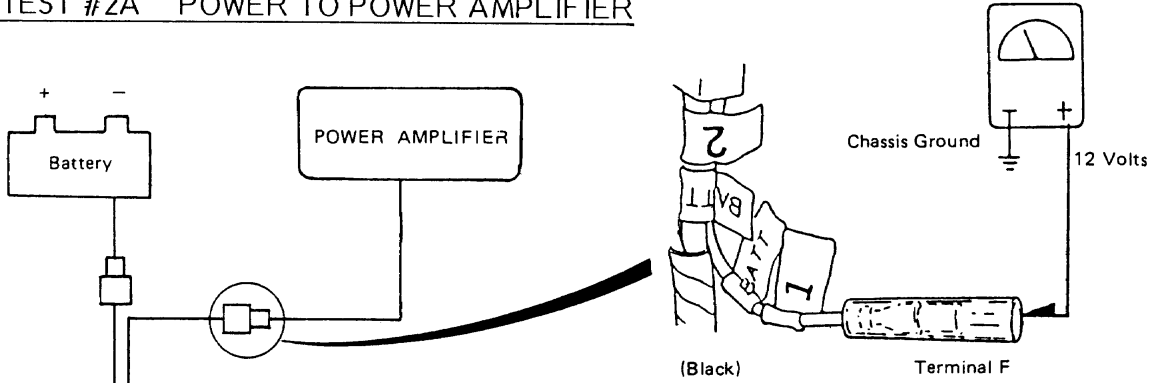

TEST #2B POWER TO RADIO TUNER

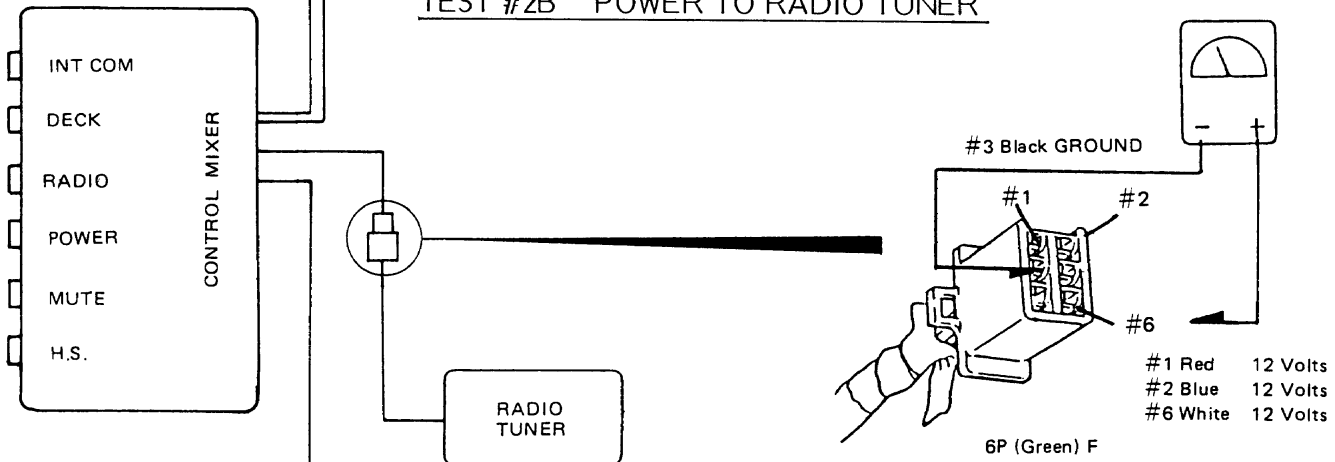

TEST #2C POWER TO CASSETTE DECK

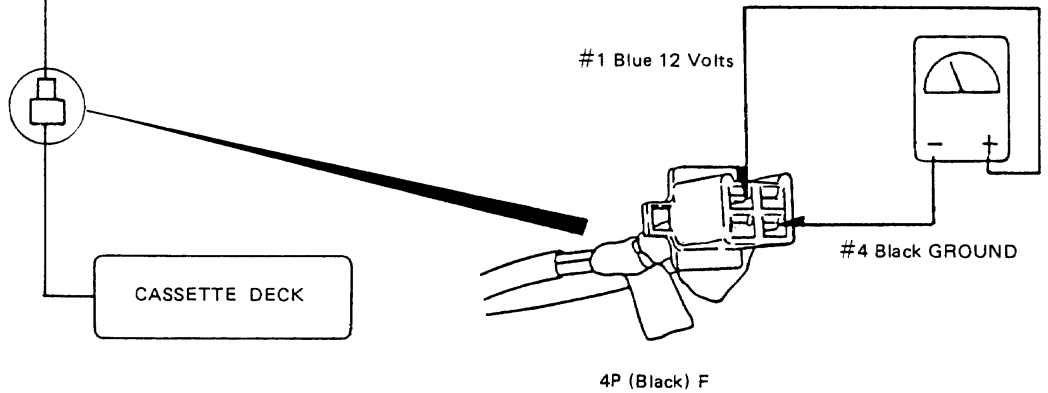

TEST #3 SPEAKER TEST

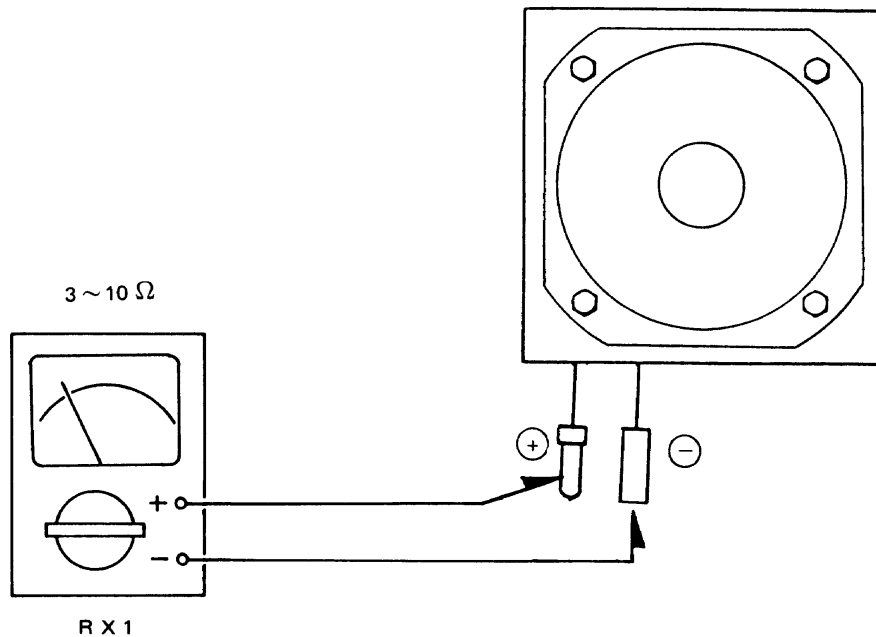

Use a multimeter in the R x 1 ohm range. Do not use a digital tester or any tester in which the reading of the resistance value cannot be carried out to the unit of a few ohms because there will be no sound when such testers are used.

First, check the voice coil for any breaks. If there is a break there will be neither continuity nor sound. When the coil is in normal condition there will be a scratching sound. The indication of the resistance value between 3 and 10 ohms means that the coil is in good condition; the indicated resistance value below 1 ohm means that there is a short in the coil. Check for a damaged voice coil which will produce either no sound or a distorted sound.

TEST #4 RADIO TUNER BYPASS TEST

STANDARD CONNECTIONS

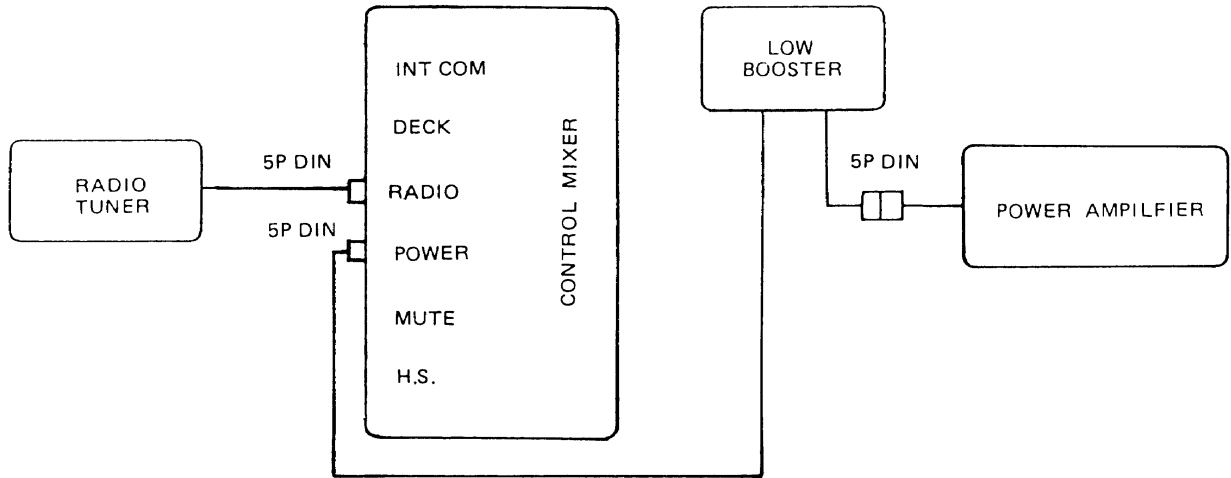

TEST CONNECTIONS
(Bypass the Control Mixer & Low Booster)

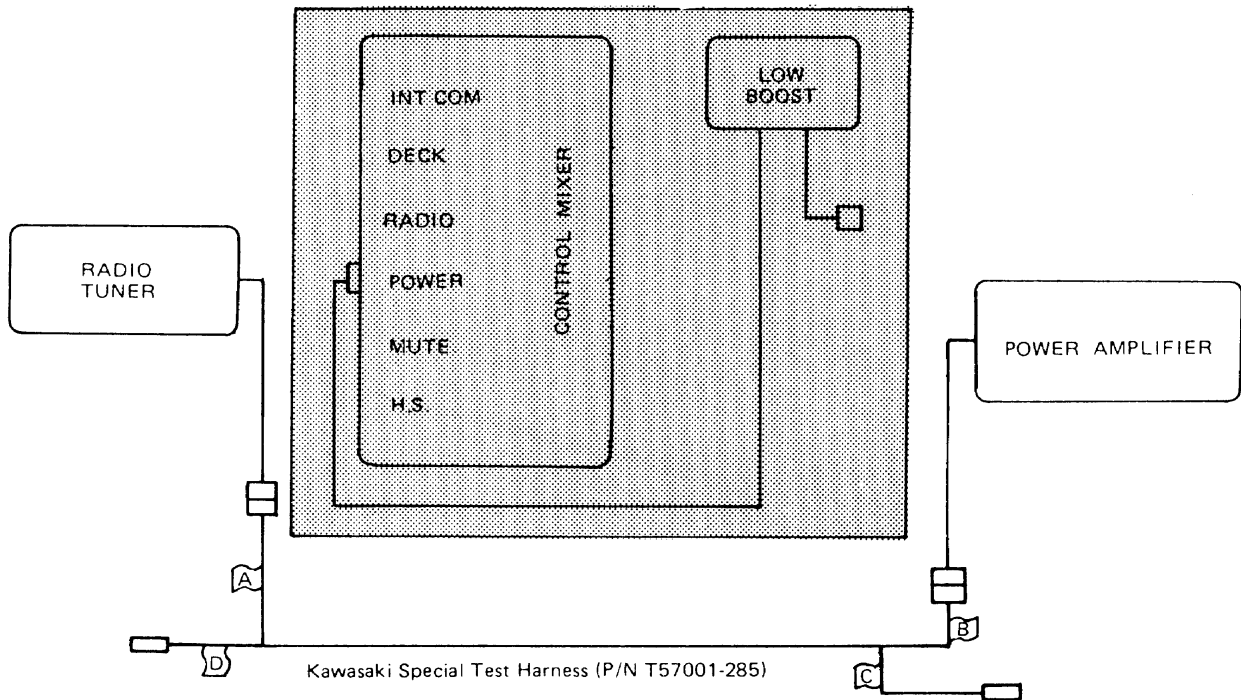

NOTE: After completing this test, reconnect audio components following the STANDARD CONNECTIONS diagram above.

TEST #5 CASSETTE DECK BYPASS TEST

STANDARD CONNECTIONS

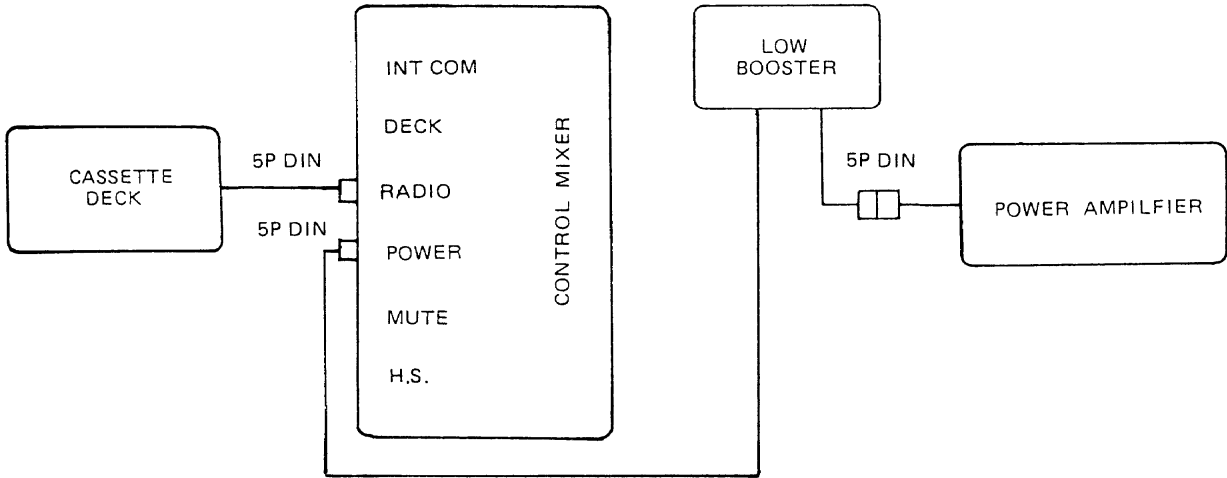

TEST CONNECTIONS
(Bypass the Control Mixer & Low Booster)

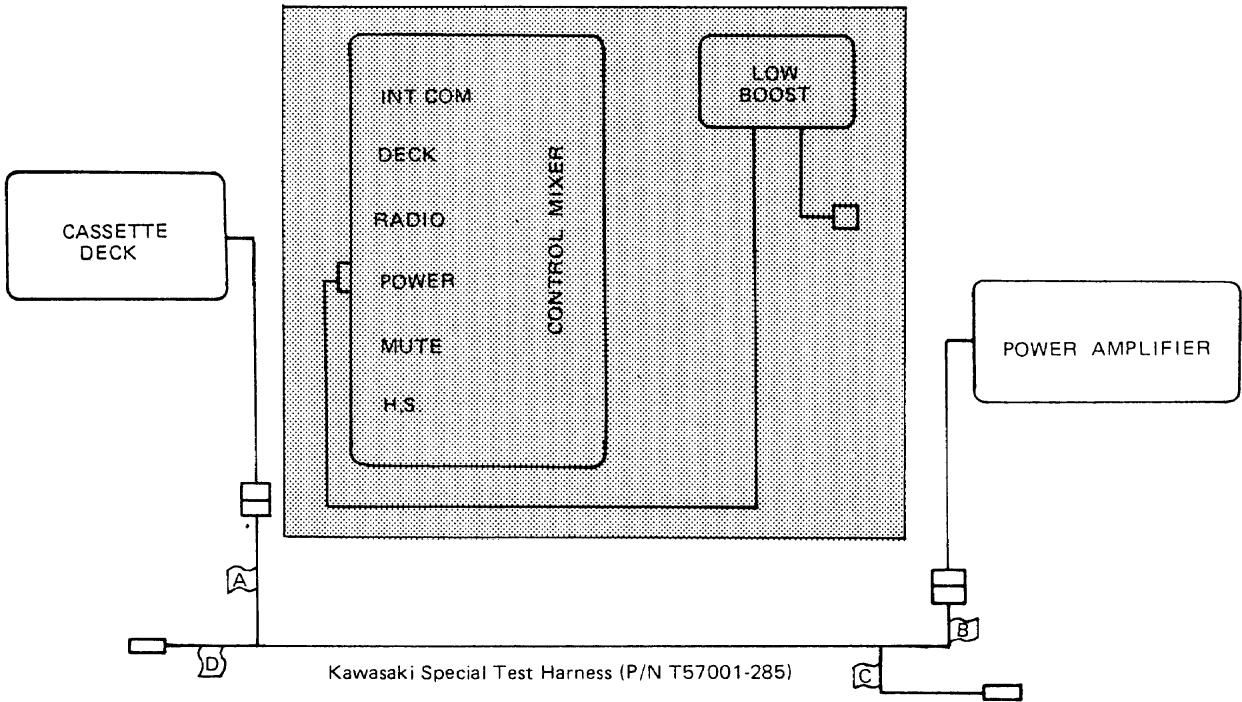

NOTE: After completing this test, reconnect audio components following the STANDARD CONNECTIONS diagram above.

TEST #6 LOW BOOSTER BYPASS TEST

STANDARD CONNECTIONS

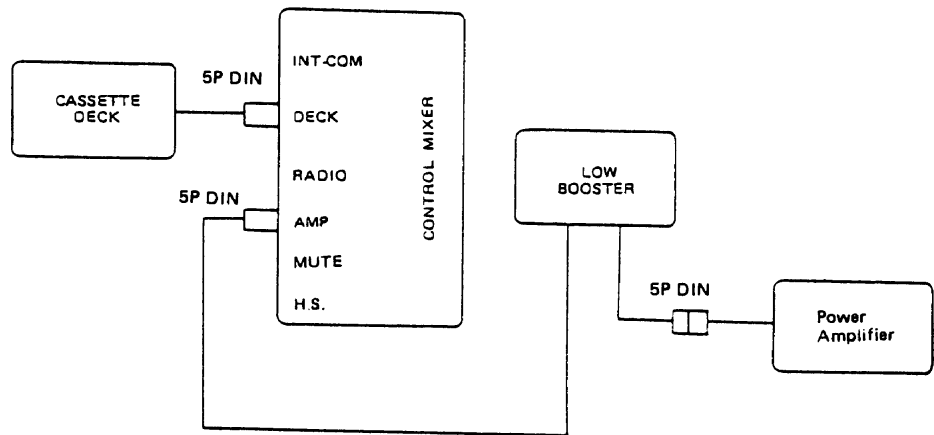

TEST CONNECTIONS (Bypass Low Booster)

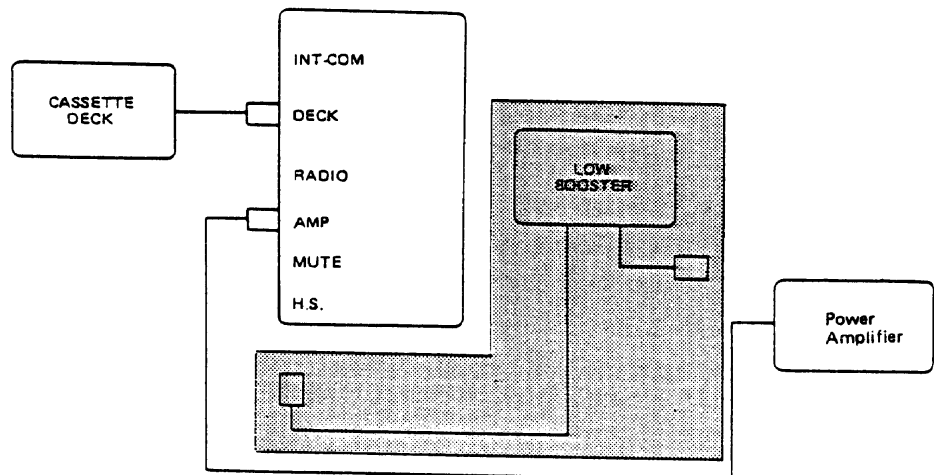

NOTE: After completing this test, reconnect audio components following the STANDARD CONNECTIONS diagram above.

TEST #7 CONTROL MIXER SWITCHING TEST

STANDARD CONNECTIONS

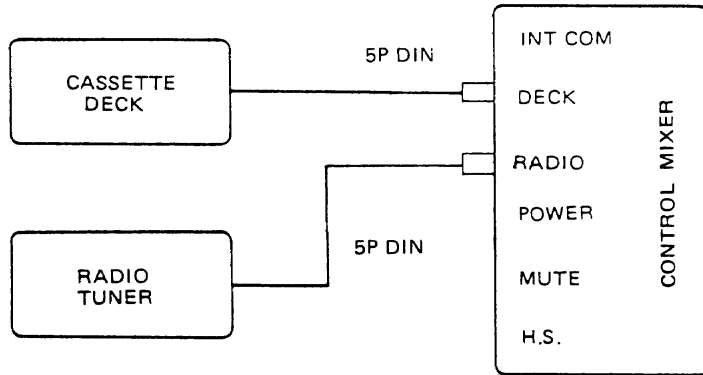

TEST CONNECTIONS

(Switch DIN connectors of Radio Tuner and Cassette Deck)

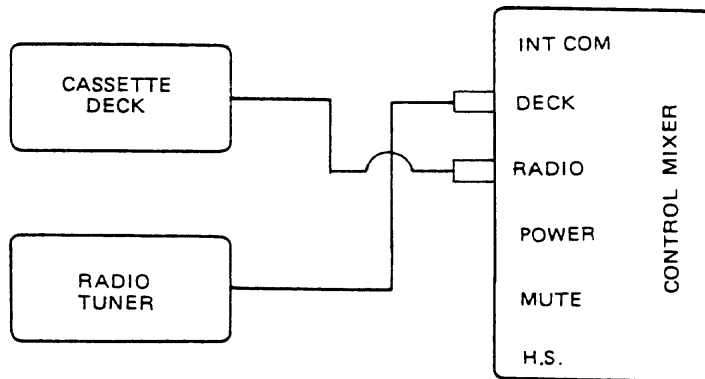

NOTE: After completing this test, reconnect audio components following the STANDARD CONNECTIONS diagram above.

TEST #8 RADIO CONTROLLER TEST

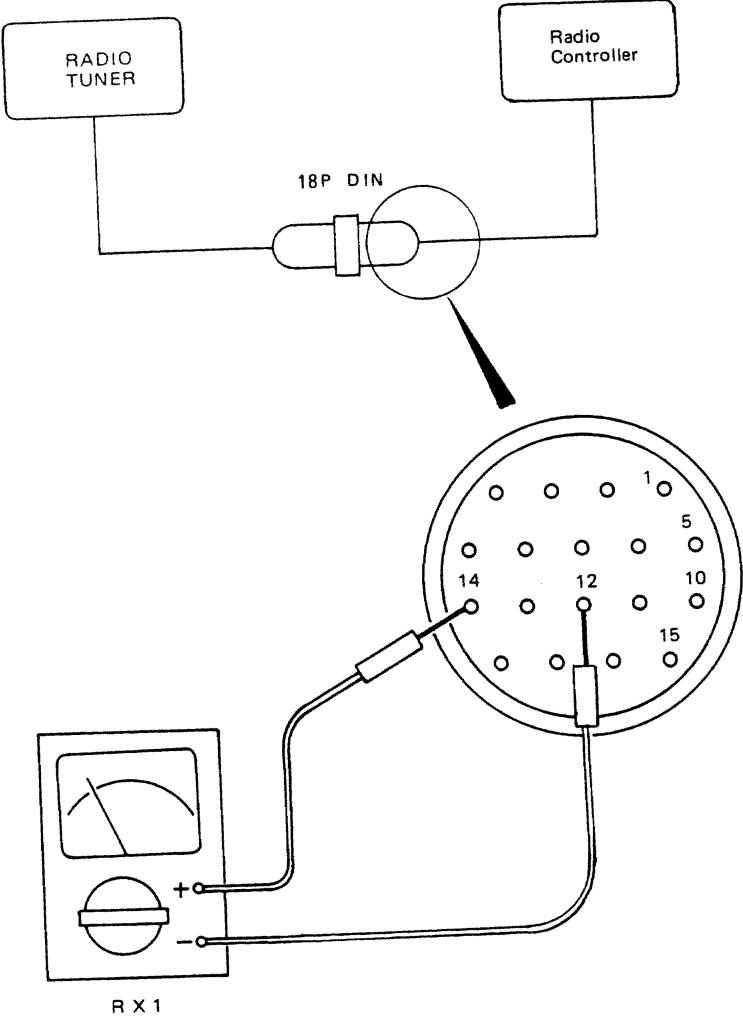

18P DIN connector from Radio Controller to Radio Tuner (TOP VIEW)

Radio Controller		
Volume switch	ON	0 Ω
Volume switch	OFF	∞

TEST #9 CASSETTE MOTOR OPERATION TEST

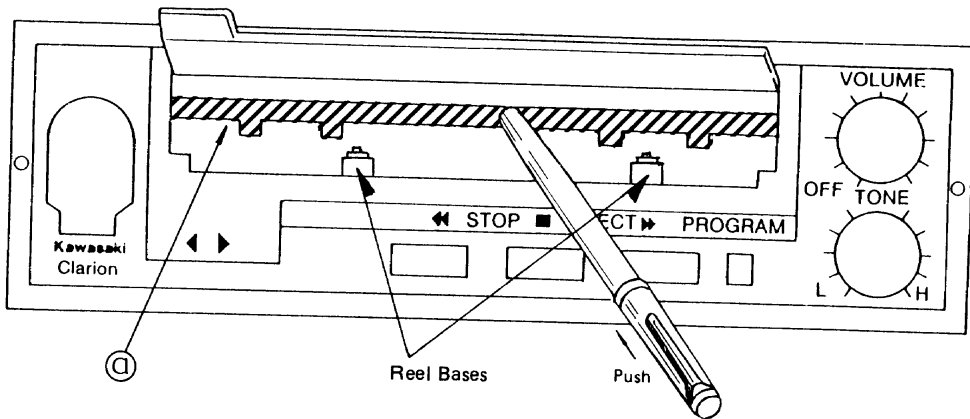

** How to operate tape mechanism without cartridge **

- Lift tape door cover
- Gently push in on cross bar **a** inside of cassette deck with a small, 10" long stick*. It will lower, and motor (one of the reel bases) will operate.
- Switch program to see if the running reelbase stops and the other reelbase starts running.
- Push eject button to release cross bar **a** to non-play position, to stop motor.

CAUTION

* Do not use metal object for this operation.

TEST #10 POWER DISTRIBUTION TO CB MODULE TEST

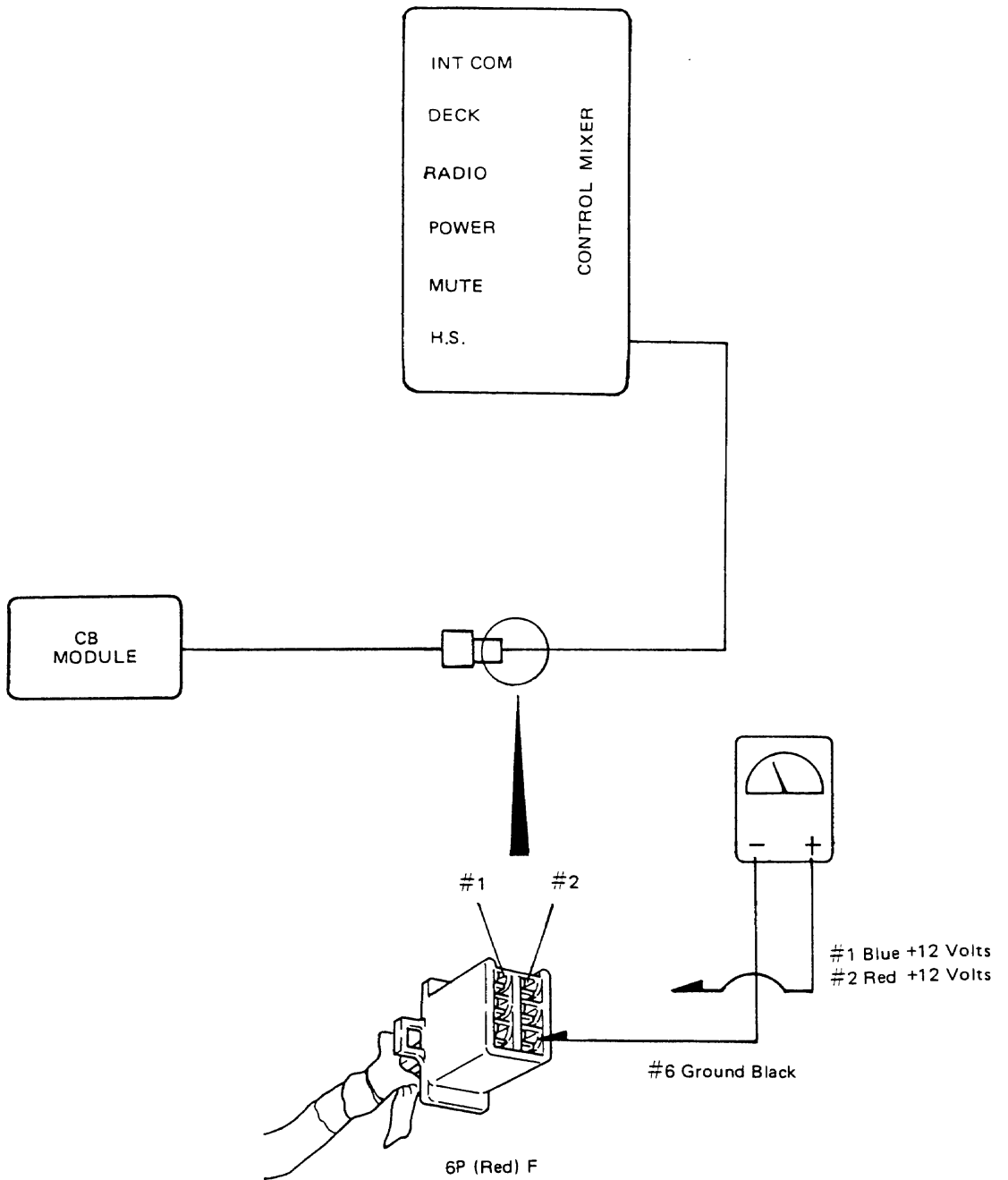

TEST #11 MUTE BOX BYPASS TEST

STANDARD CONNECTIONS

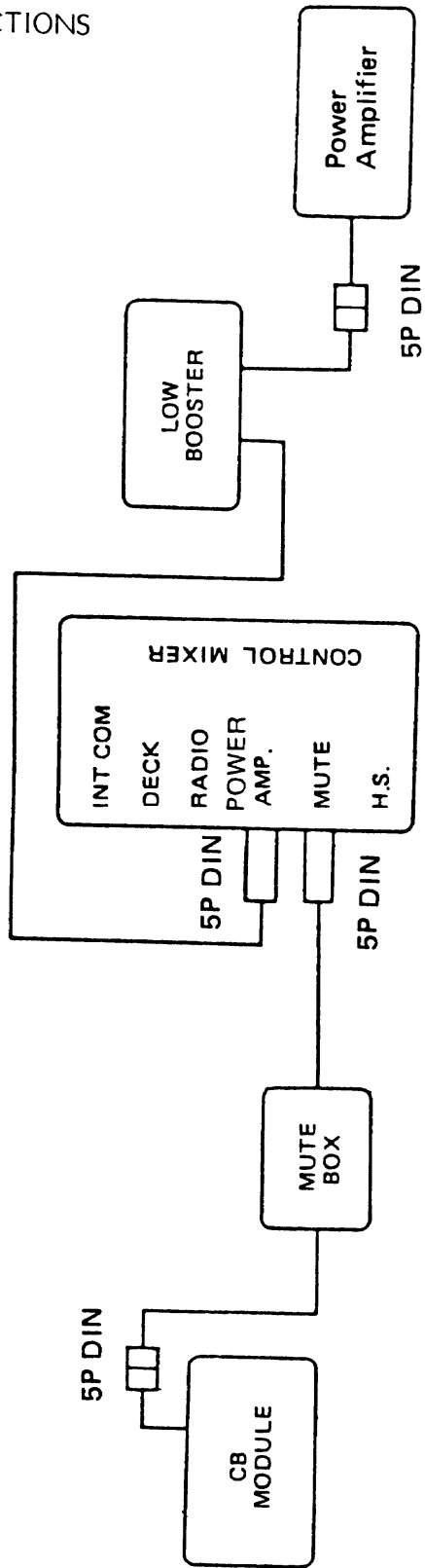

TEST CONNECTIONS
(Bypasses the Mute Box)

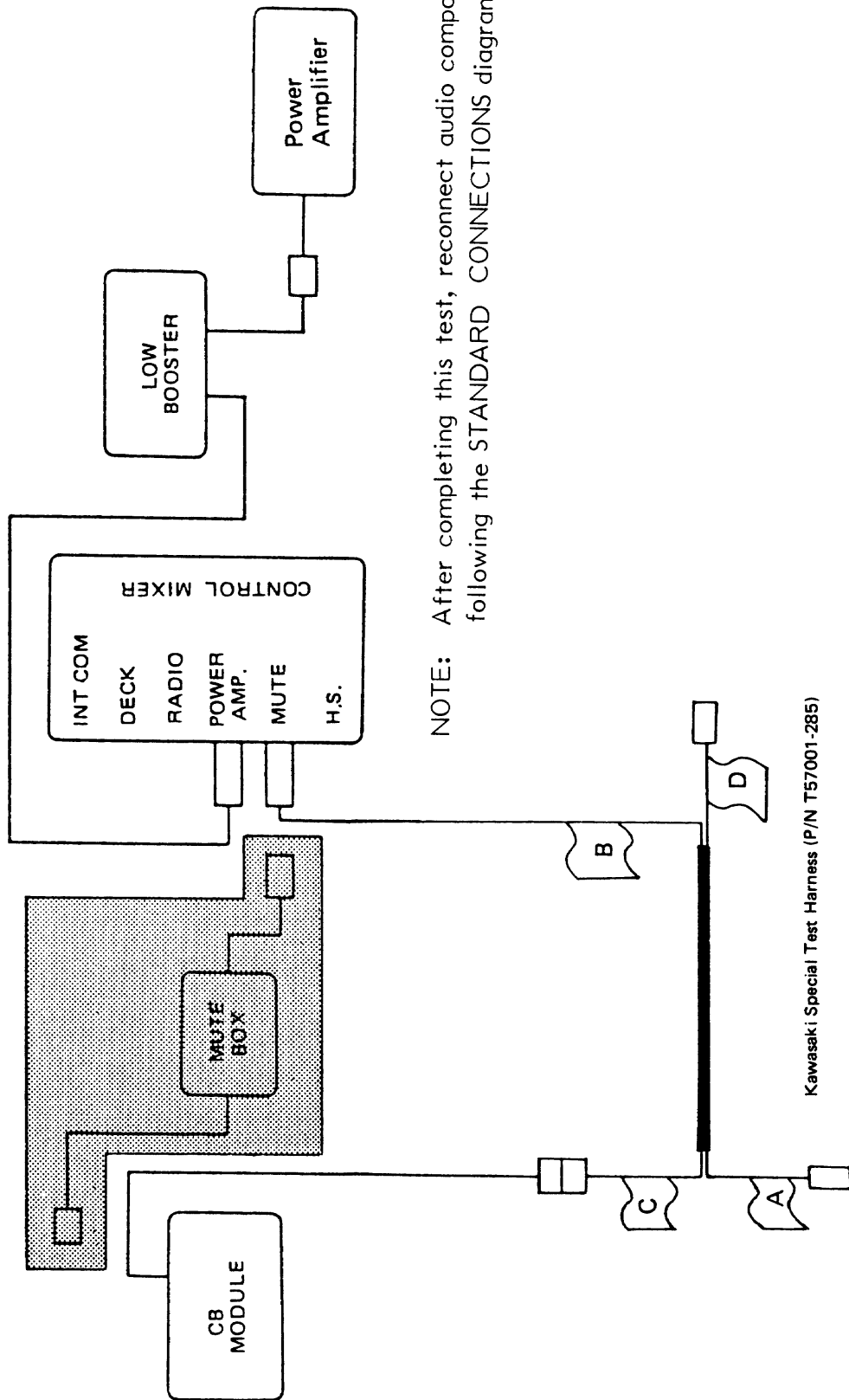

NOTE: After completing this test, reconnect audio components following the STANDARD CONNECTIONS diagram above.

Kawasaki Special Test Harness (P/N T57001-285)

TEST #12 ANTENNA CONNECTION TEST

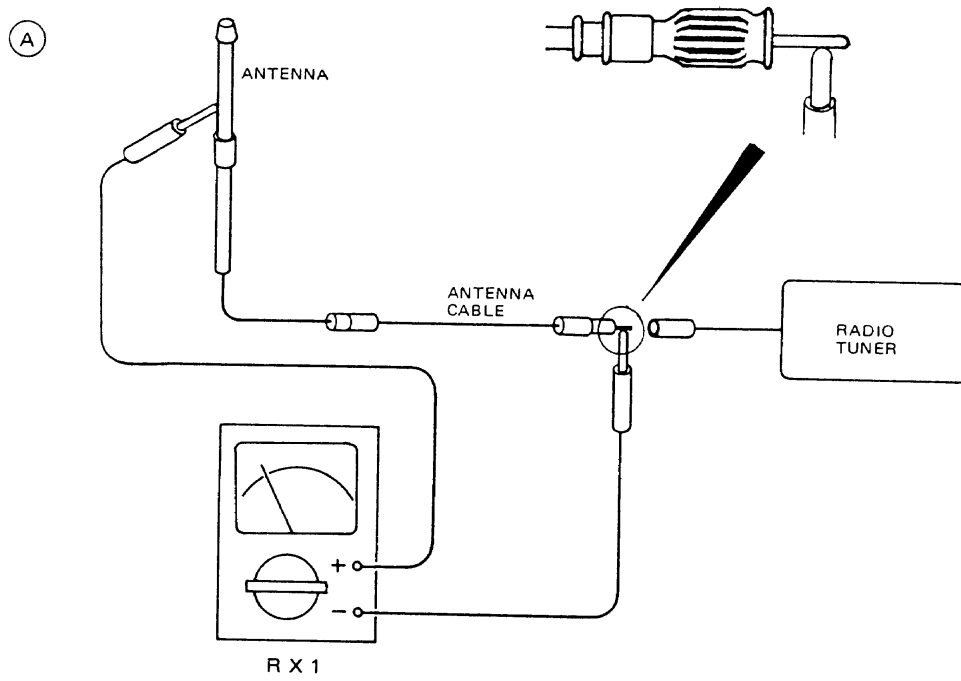

The meter should indicate almost 0 Ω .

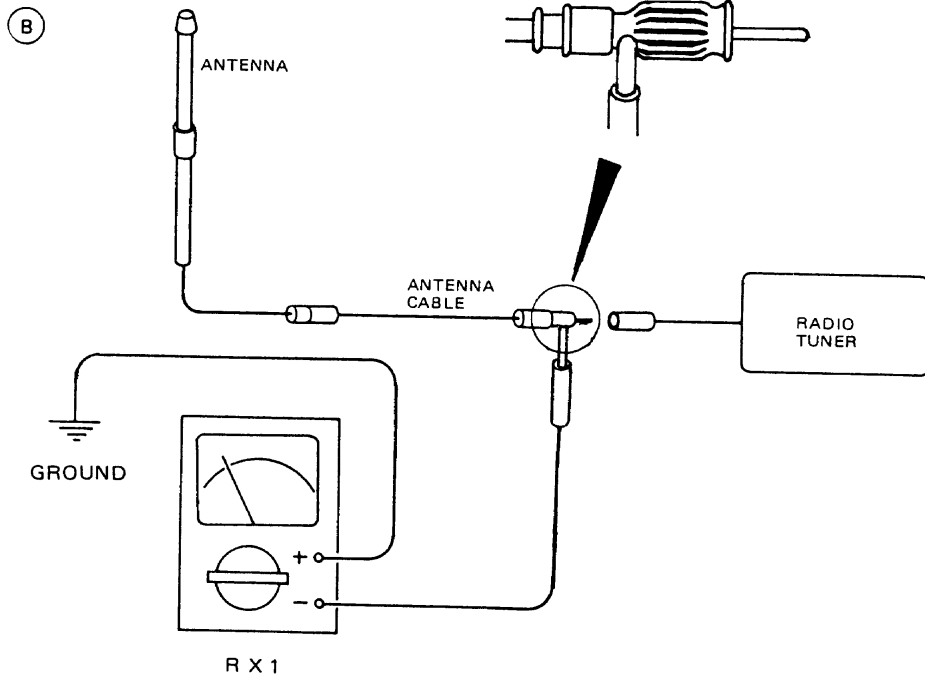

The meter should indicate almost 0 Ω .

TEST #13 ANTENNA BOX BYPASS TEST

STANDARD CONNECTION

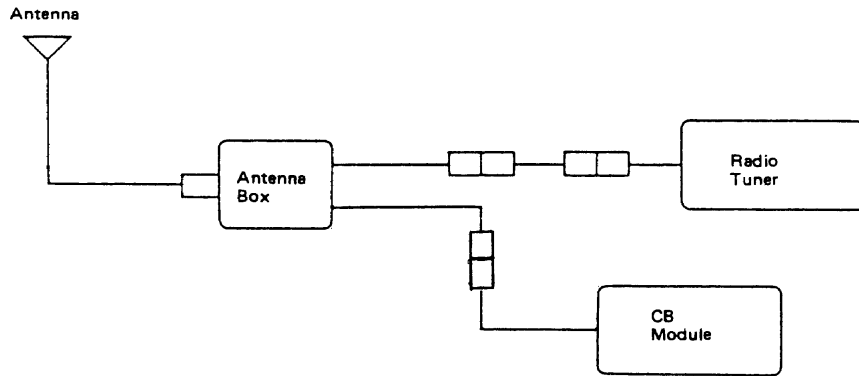

TEST #13A

TEST CONNECTION
(Bypass Antenna Box)

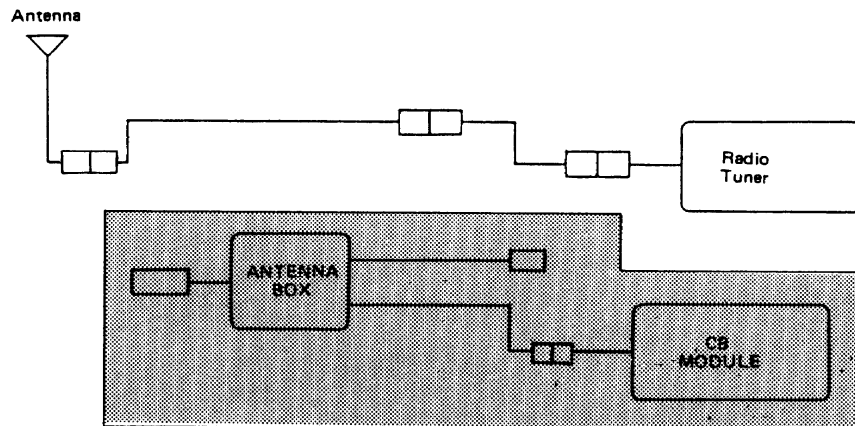

TEST #13B

TEST CONNECTION
(Bypass Antenna Box)

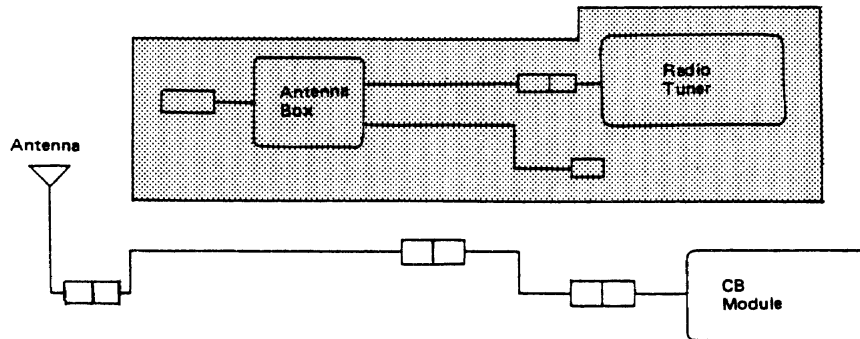

NOTE: After completing this test, reconnect audio components following the STANDARD CONNECTIONS diagram above.

TEST #14 CB ANTENNA ADJUSTMENT

CB adjustment consists of tuning the antenna system for maximum FS (Field Strength) and minimum SWR. (Standing Wave Ratio). An FS/SWR meter is required. This type of meter is commonly available at electronic supply stores such as Radio Shack for about \$20.00. The antenna box and the CB module are mounted under the fairing storage compartment.

CB adjustments must be performed outdoors, in an open area, away from any electrical interference.

FIELD STRENGTH

Adjust FS first, then SWR. After adjusting SWR, check FS again and adjust if necessary.

- o Set the FORWARD/REFLECTED switch on the meter to the FORWARD position.
- o Place the meter on the fairing, inside the wind screen.
- o Turn the vehicle ignition switch to ACC.
- o Set the CB on CHANNEL 20.
- o Press and hold the CB Talk Switch.
- o Adjust the calibration knob so that the meter needle is about mid-scale.
- o Using a non-metallic screwdriver, adjust the CB antenna trimming screw on the antenna box.
- o Adjust the trimming screw for maximum FS as indicated by the meter needle.

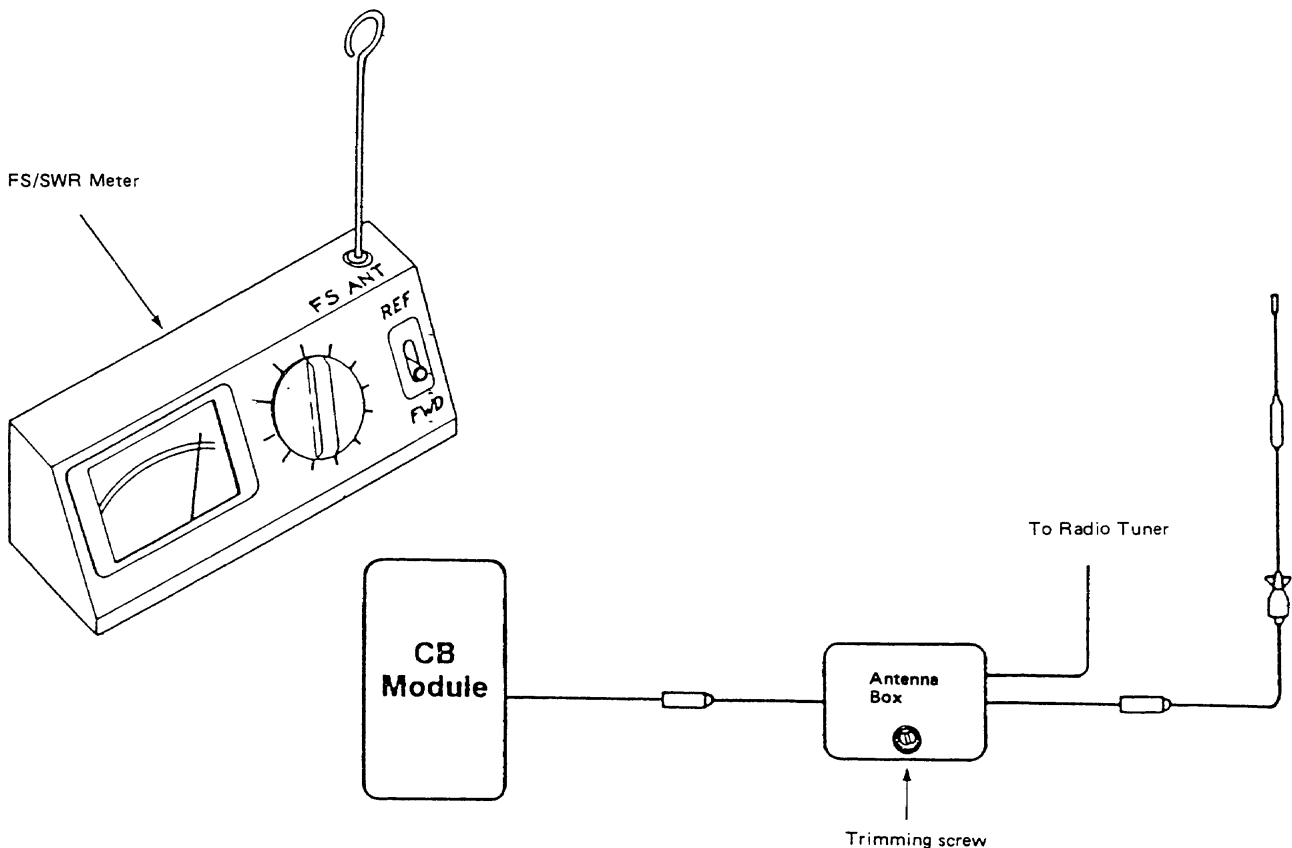

STANDING WAVE RATIO

- o Connect the meter as shown.
- o Turn the vehicle ignition switch to ACC.
- o Set the FORWARD/REFLECTED switch on the meter to the FORWARD position.
- o Set the CB on CHANNEL 20.
- o While holding down the CB TALK button, adjust the calibration knob so that the meter indicates CAL.
- o Release the talk button.
- o Flip the FORWARD/REFLECTED switch to the REFLECTED position.
- o Depress the talk button and read the SWR meter. If the antenna is tuned properly, the meter will indicate an SWR of 1.5 or less.

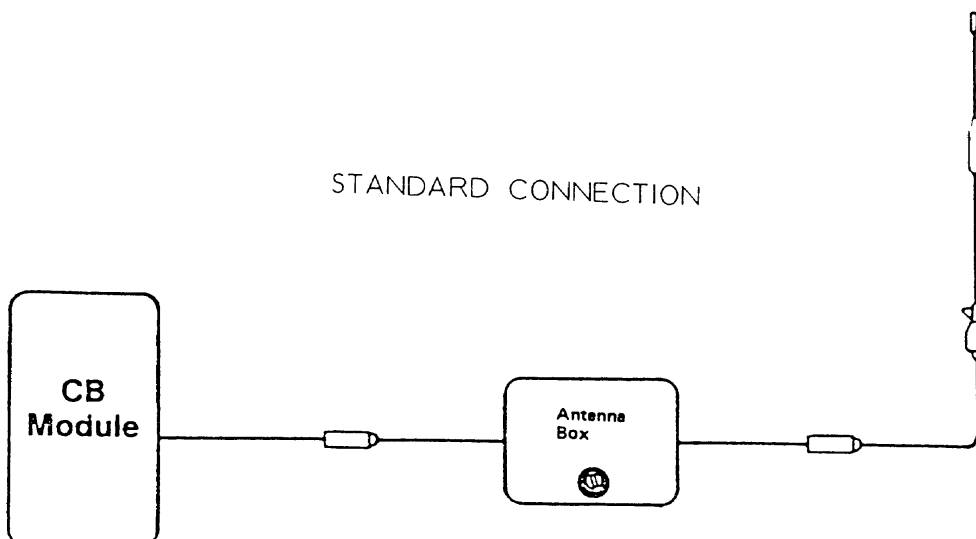
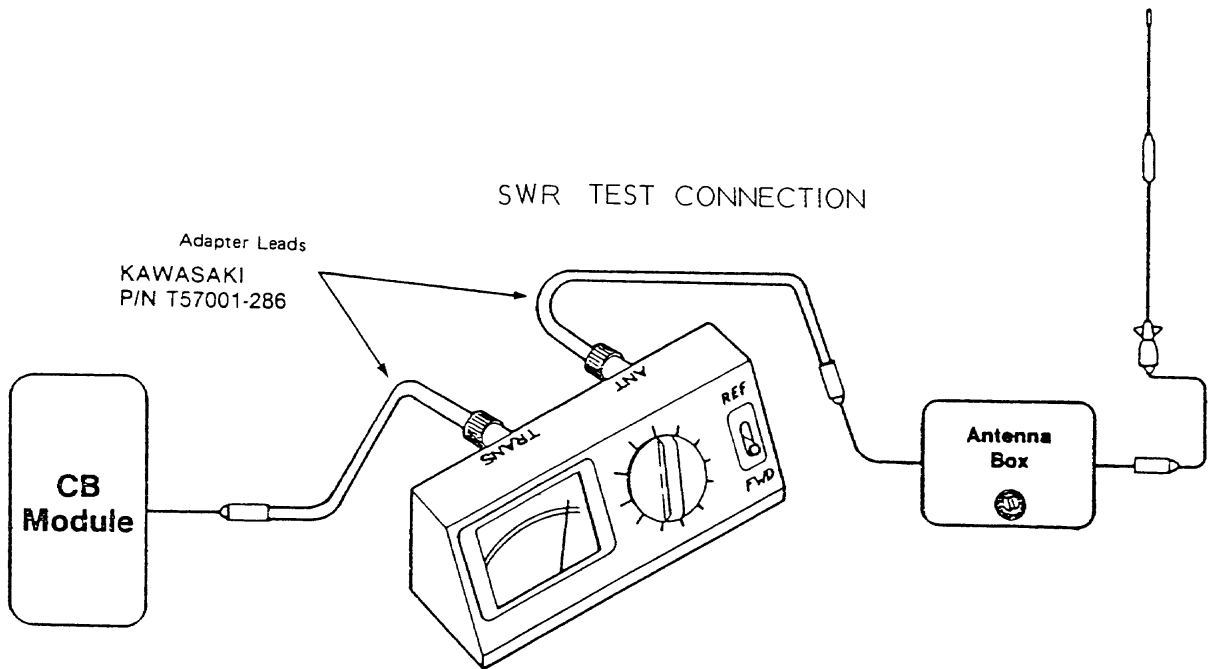

ANTENNA ADJUSTMENT

- o If the SWR is higher than 1.5, loosen the setscrew (see note below) and remove the antenna upper section from the aluminum housing.
- o Cut 3 mm from the bottom of the antenna upper section.
- o Reinstall the antenna upper section in the housing and repeat the SWR test procedure.
- o Continue cutting 3 mm at a time from the antenna upper section and repeating the SWR test procedure until the SWR begins to increase.
- o Raise the antenna upper section in the aluminum housing until the SWR drops again to the lowest meter reading, then tighten the setscrew.

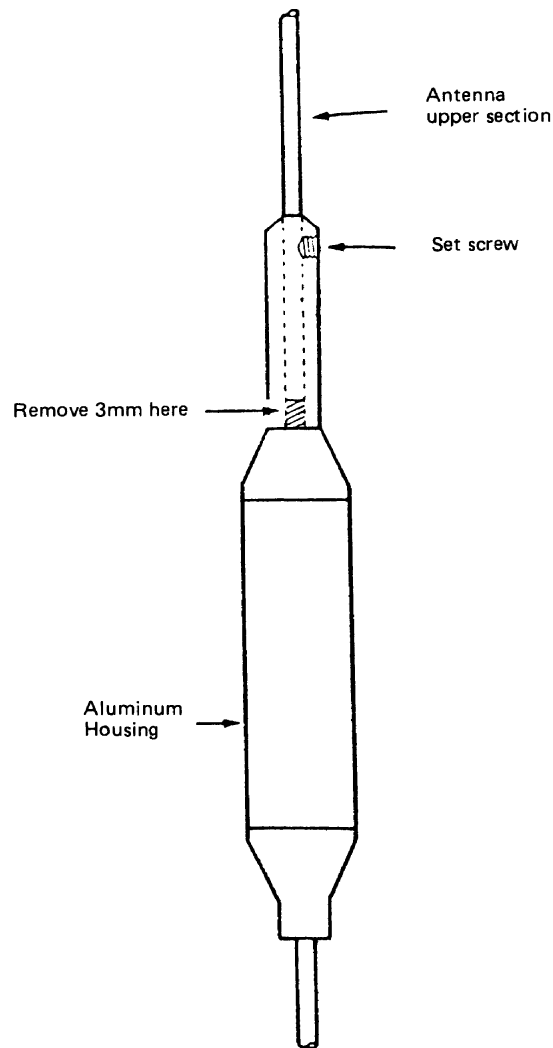

TEST #15 HANDLE SWITCH TEST

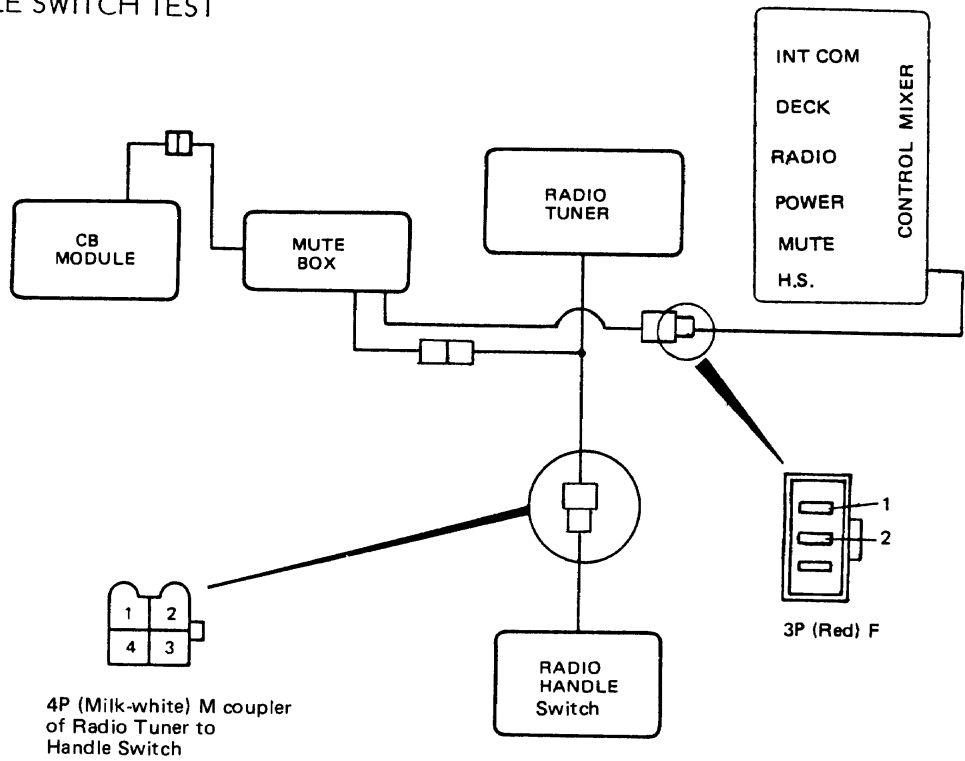

TEST #15A AUTO SEEK TUNING

Check if AUTO SEEK works by connecting Pin #1 and Pin #2 by a jumper wire.

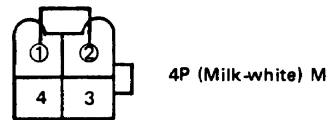

TEST #15B MUTING (I)

Check if MUTING works by connecting Pin #3 and Pin #4 by a jumper wire

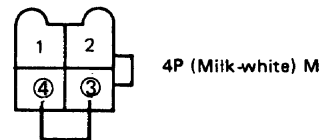

TEST #15C MUTING (II)

Check if MUTING works by connecting Pin #1 and Pin #2 by a jumper wire

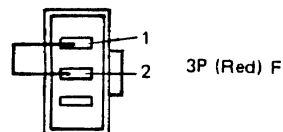

TEST #16 RADIO DISPLAY TEST

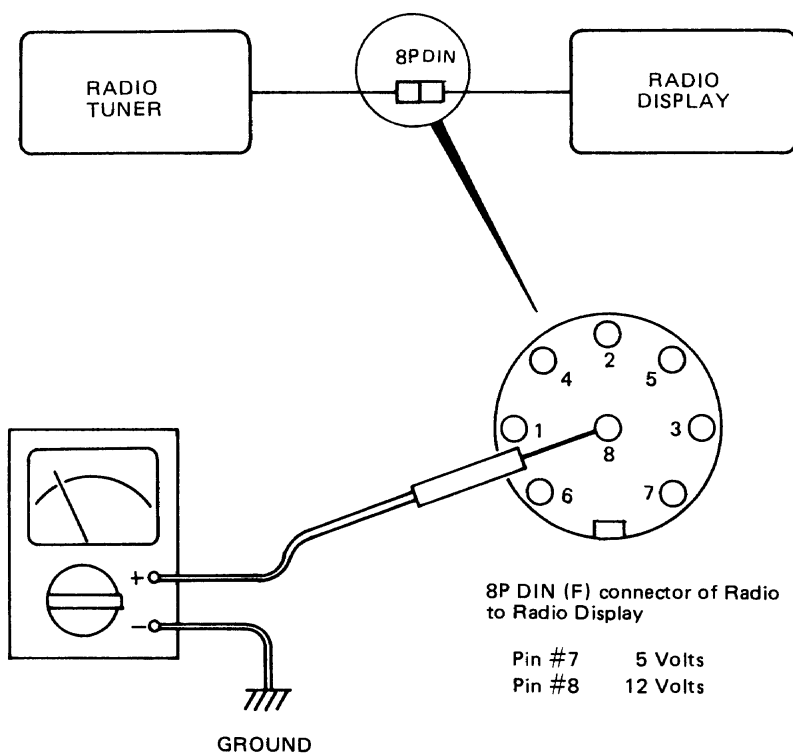

Use a multimeter in 10 volts or 50 volts D.C. range.

CAUTION

Take care not to short circuit.

TEST #17 CB DISPLAY TEST

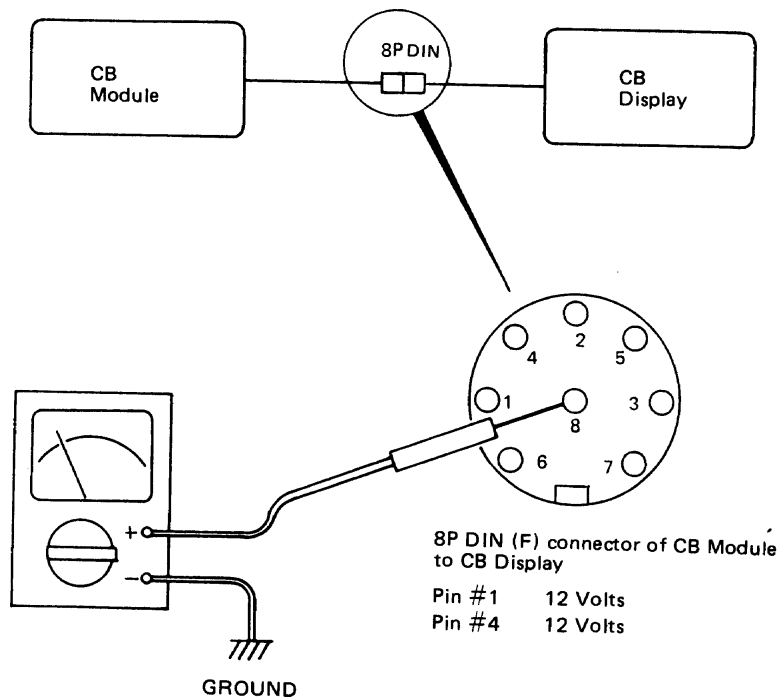

Use a multimeter in 50 volts D.C. range.

CAUTION

Take care not to short circuit.

TEST #18 INTERCOM CONTROLLER TEST

Remove Intercom Controller from Controller case

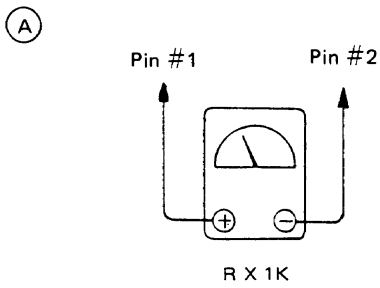
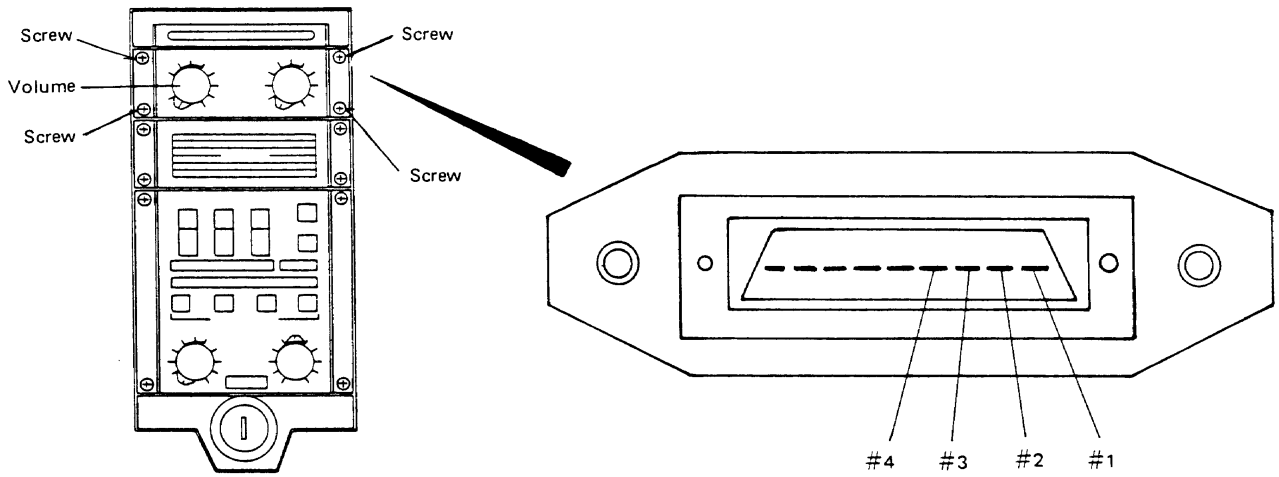

When turning the Volume, multimeter should show 0 to 20K Ω .

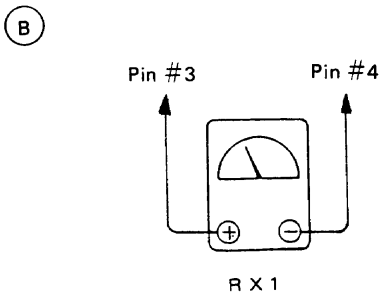

Volume OFF ∞
 ON 0 Ω
 (at any position)

TEST #19 CONTROLLER TEST

Remove CB Controller from controller case

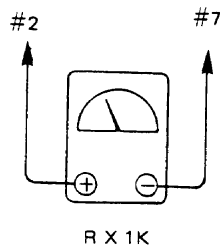
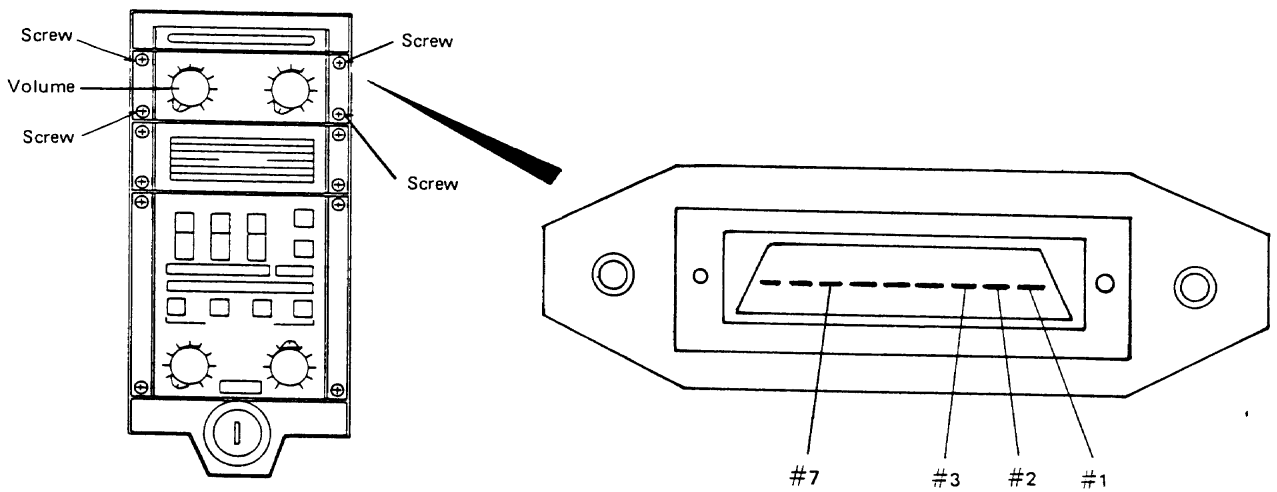

When turning the Volume, multimeter should show 0 to 30K Ω .

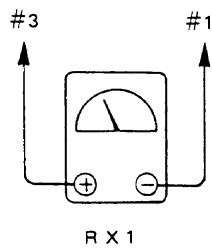

Volume OFF ∞
ON 0 Ω
(at any position)

TEST #20 SPEAKER SWITCH TEST

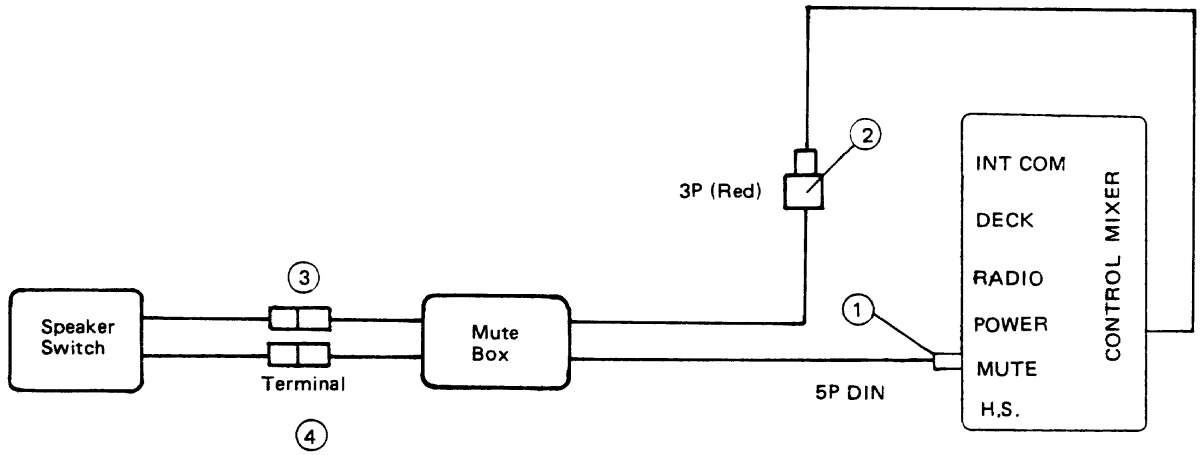

TEST #20A

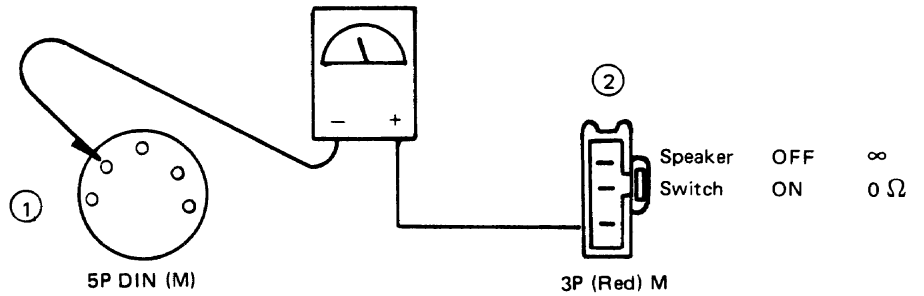

TEST #20B

NOTE: If Test #20A is OK, no need for this test.

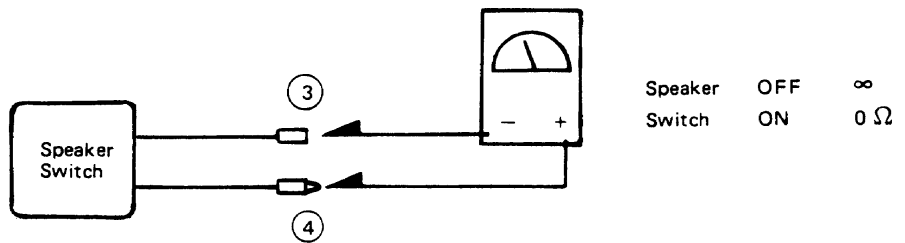

TEST #21 HELMET SOUND SYSTEM (AND BRANCH LEAD) TEST

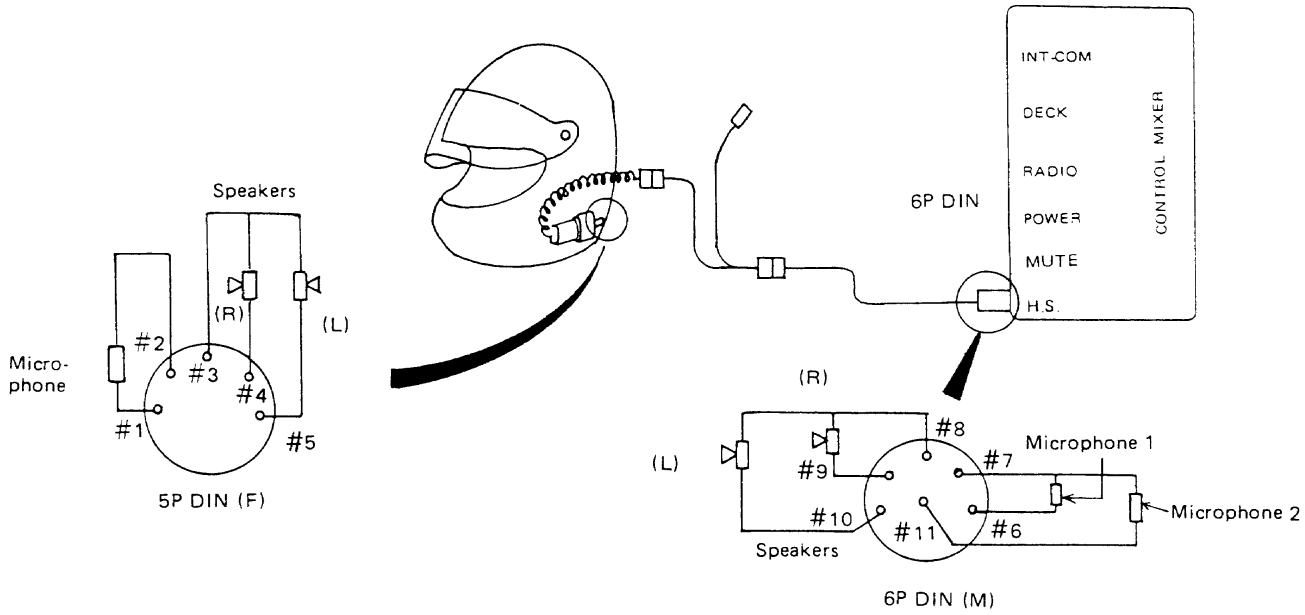

TEST #21A SPEAKER TEST

TEST #21B

NOTE: If Test #21A is OK, no need for this test.

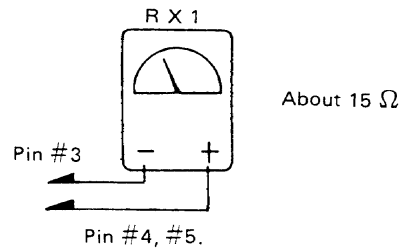
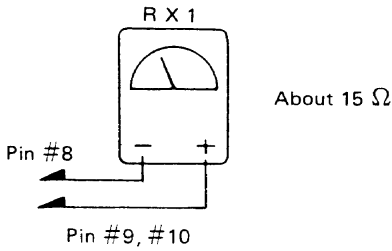

TEST #21C MICROPHONE TEST

TEST #21D

NOTE: If Test #21C is OK, no need for this test.

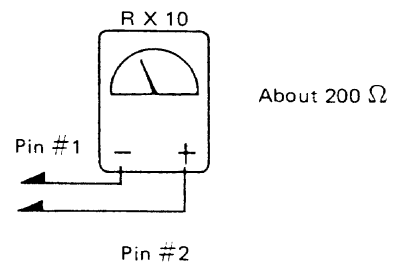
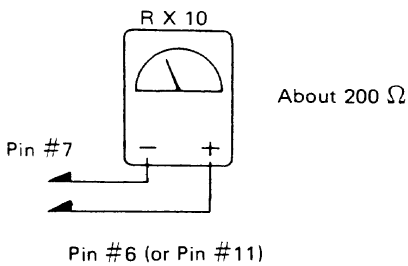

TEST #22 HANDLE SWITCH TEST (CB)

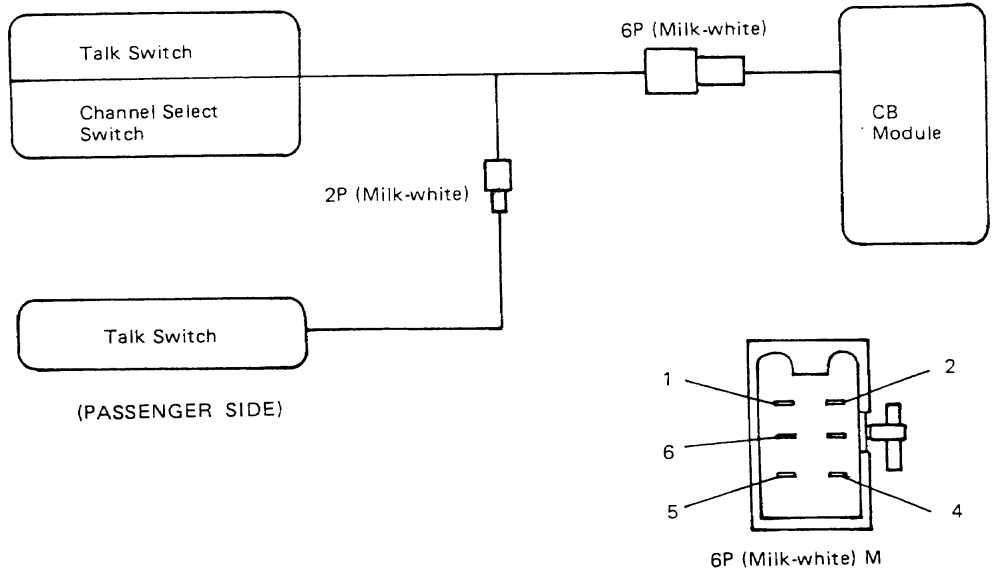

TEST #22A TALK SWITCH TEST

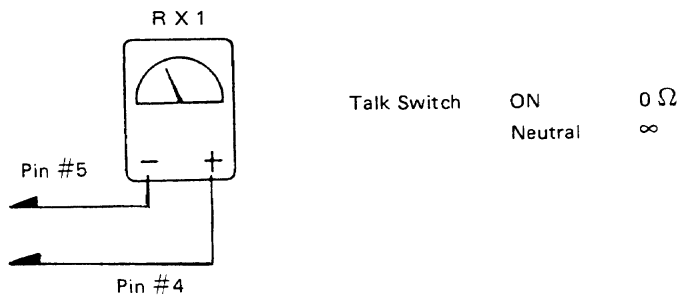

TEST #22B CHANNEL SELECT SWITCH

(CHANNEL UP)

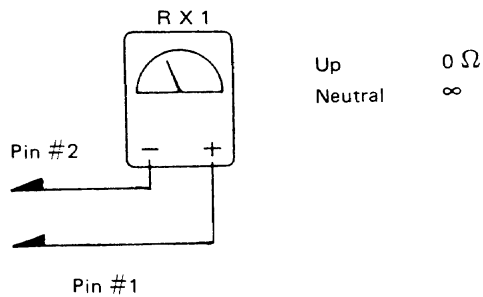

(CHANNEL DOWN)

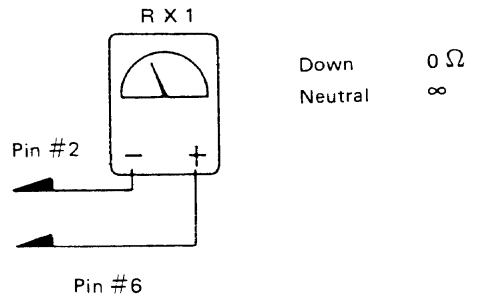

TEST #23 MUTE BOX BYPASS TEST

STANDARD CONNECTIONS

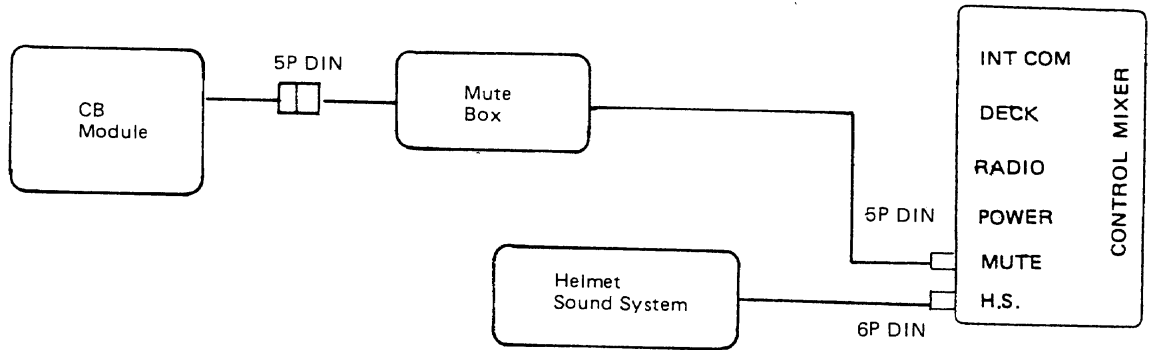

TEST CONNECTIONS (Bypass Mute Box)

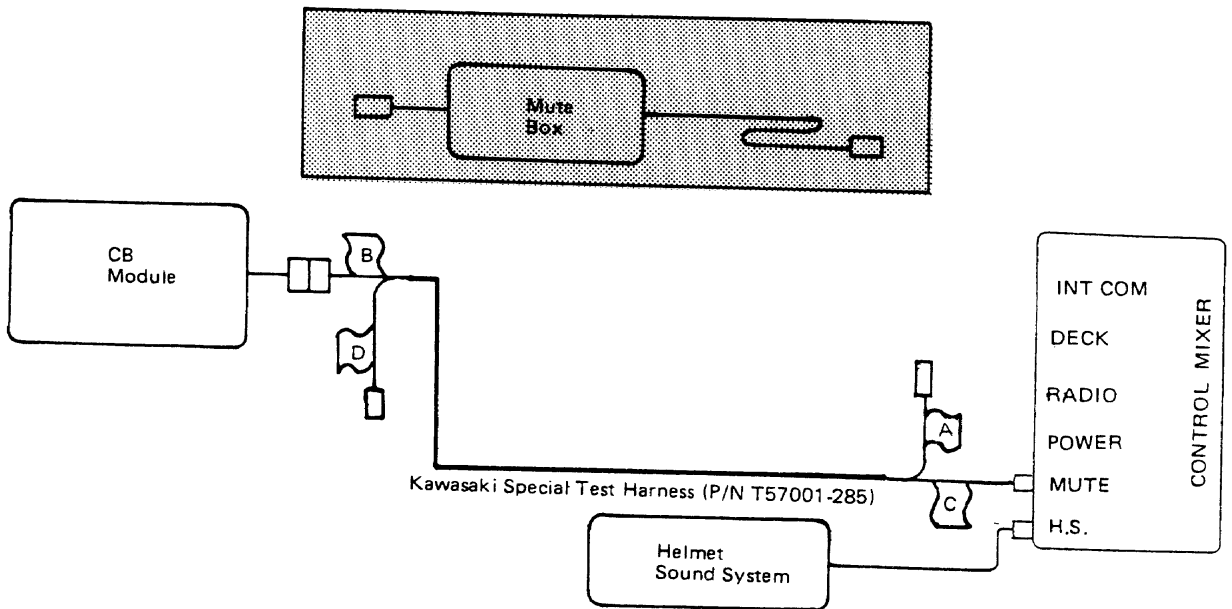

CAUTION

Speakers do not work with this test connections.

NOTE: After completing this test, reconnect audio components following the STANDARD CONNECTIONS diagram above.

ATTACHMENT I WIRING AND CONNECTOR IDENTIFICATION

Two-color Lead Identification

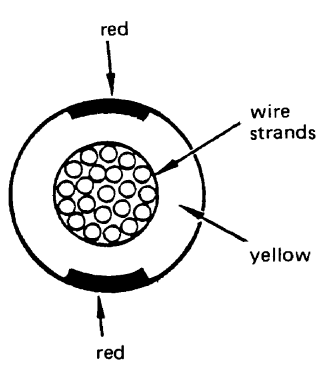
<p>Lead (cross-section)</p>	
<p>Name of Wire Color</p>	<p>yellow/red (YEL/RED)</p>

Electrical connectors:

Female-Connectors (F)

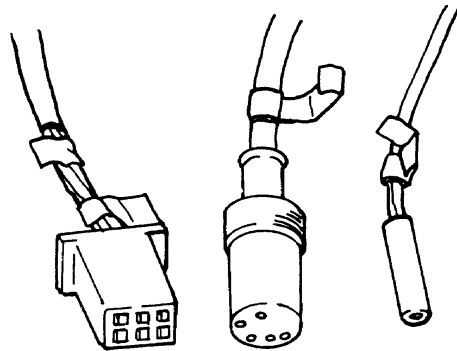

Male Connectors (M)

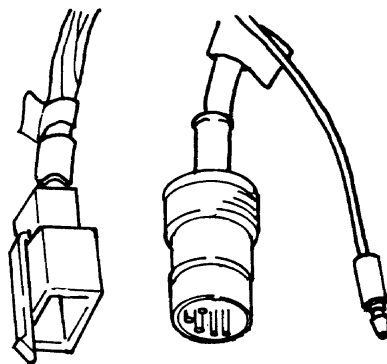

ATTACHMENT II WIRING DIAGRAMS (STANDARD)

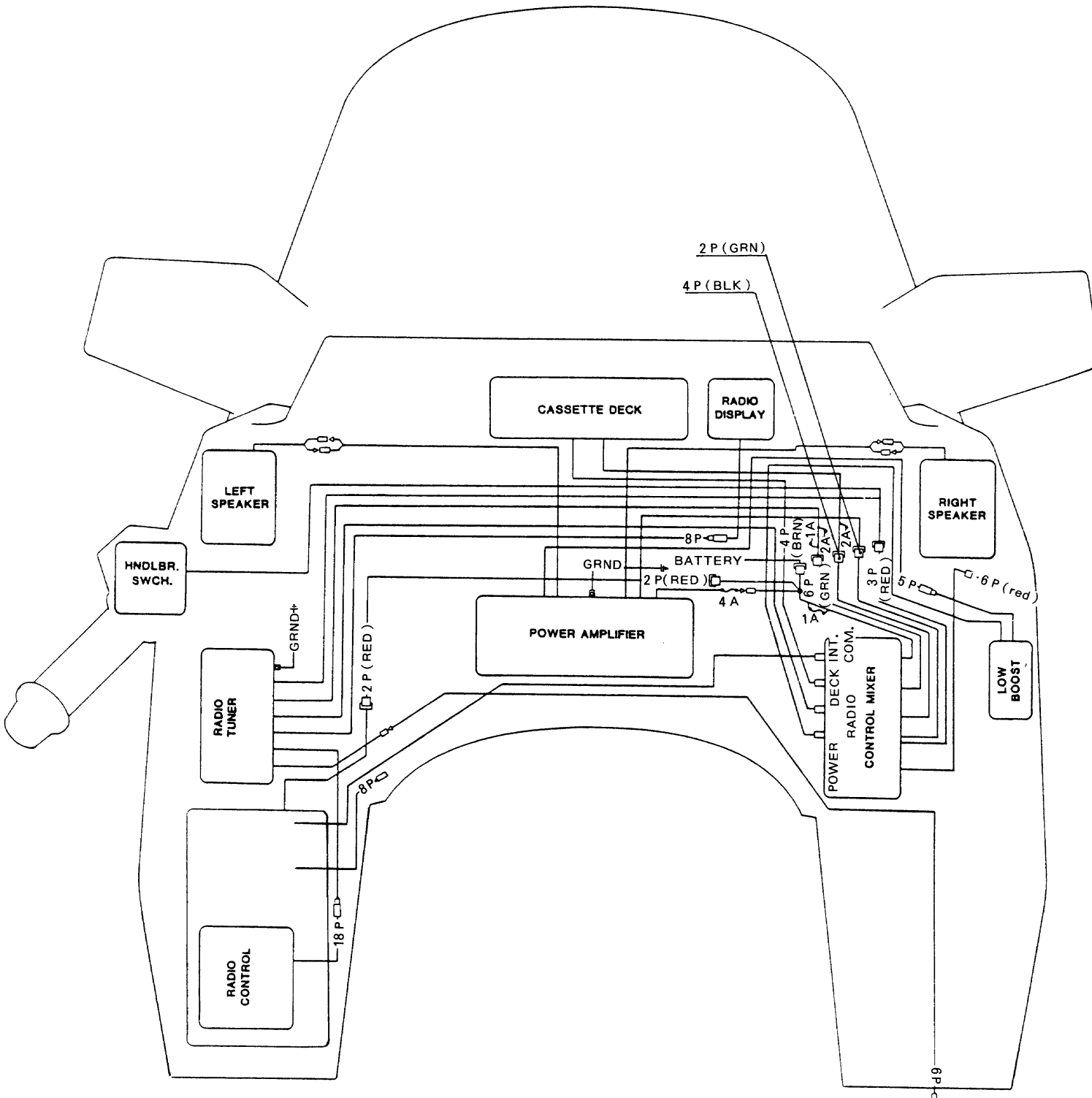

ATTACHMENT III WIRING DIAGRAMS (INCLUDES ALL OPTIONAL UNITS)

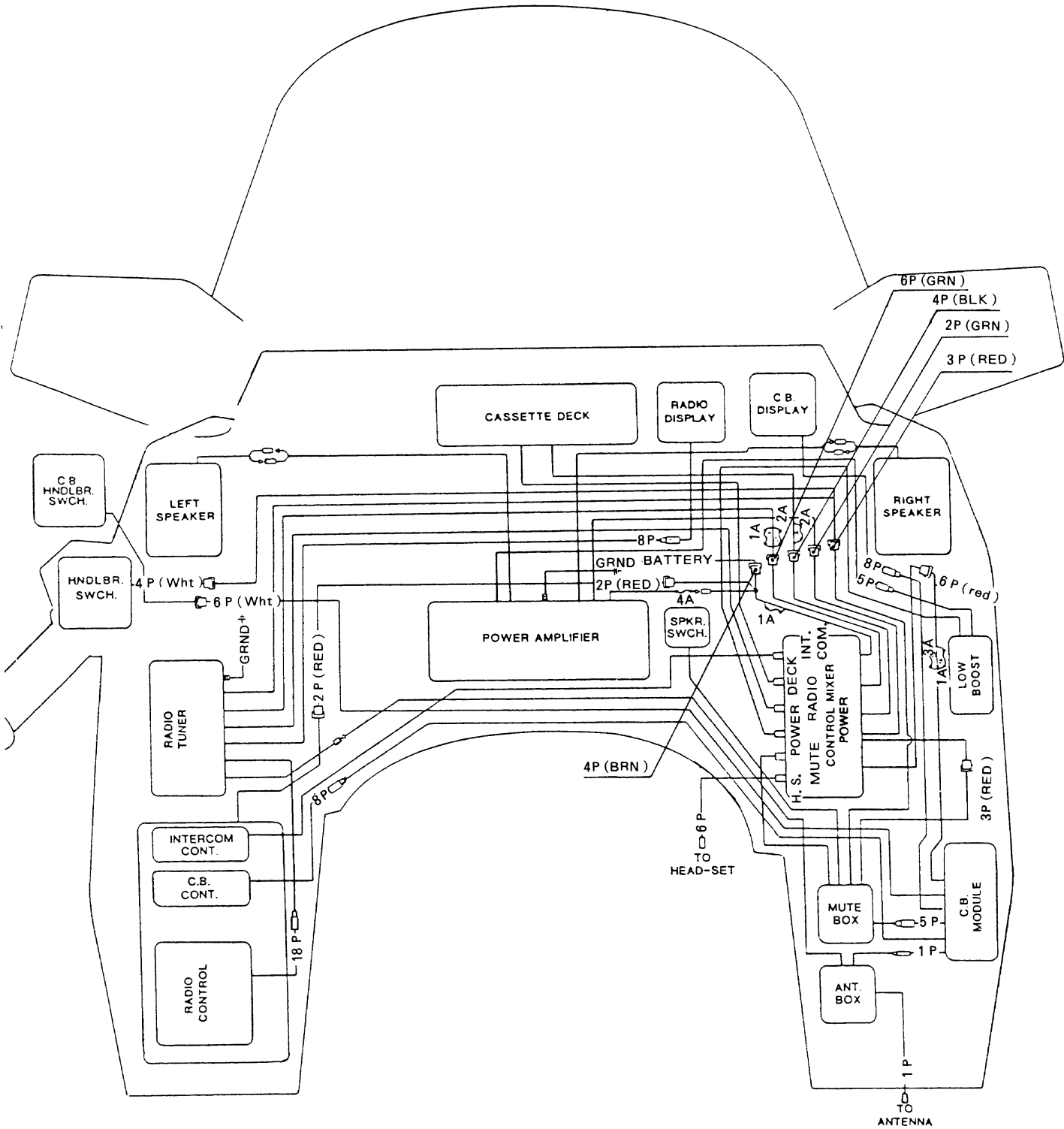

ATTACHMENT IV AUDIO SYSTEM OPERATION CHECKLIST

Before moving on to the individual troubleshooting flow charts and test procedures, take a few minutes to check the operation of the entire audio system. Since the functions of many components are interrelated, there may be other problems not reported by your customer. Knowing the whole picture will simplify your job by ensuring that you start troubleshooting with the proper flow charts and test procedures.

Be sure to complete this checklist before calling the HOT LINE with any audio system problem. The HOT LINE staff will ask questions based on this checklist.

Make the operation checks as requested. If any malfunctions occur, check the box to the right, then check the affected components and controls or features.

Operation Checks

Malfunctions?

1. Is radio reception normal?
 AM FM CB
2. Do all audio systems produce sound?
 AM/FM Radio Cassette Deck
 CB Transceiver Intercom
3. Does left channel function?
 Headset Fairing Speaker
4. Does right channel function?
 Headset Fairing Speaker
5. Does CB transceiver transmit normally?
6. Do left handlebar switches function?
 TUNE MUTE
 TALK DN-UP
7. Does passenger Talk Switch function?
8. Do Radio Controller controls function?
 Power/Volume Control Switch TONE
 MEMORY TUNING buttons FM/AM switch
 DX/LO switch UP/DN switch
 FREQ button ADJ button
9. Do CB controls function?
 Power/Volume Control Switch
 Squelch
10. Do Intercom controls function?
 Power/Volume Control Switch
 SP/MUTE switch

Operation Checks

Malfunctions?

11. Does Radio/Clock Display function?
- a.m. p.m. STEREO
- LOCAL AM FM
- MEMORY Time
- Radio Frequency
12. Does CB display function?
- CB TX
- Channel
13. Does speaker switch for CB function?
14. Do cassette Deck controls function?
- Power/Volume Control Switch
- TONE PROGRAM change button
- Program Indicators STOP/EJECT button
- F.F./Rew. Buttons

PLEASE CORRECT THE FOLLOWING TYPOGRAPHICAL ERRORS

INCORRECT

CORRECT

1/-Page 2

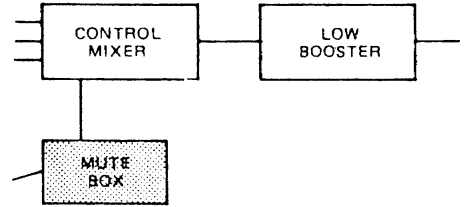
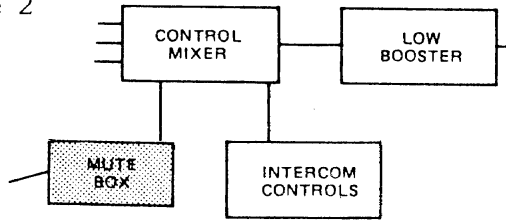

2/-Page 11
(line 1)

... at the back of this manual
(page 15)

... at the back of this manual
(page 61)

3/-Page 34
and 35



4/-Page 35

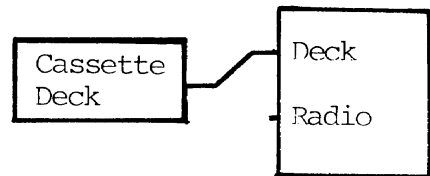
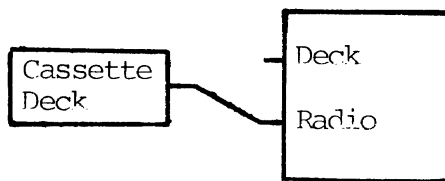

5/-Page 52

