

Quick Reference Guide

To use, bend the manual back and match the desired chapter below against the black spot showing at the edge of these pages.



Junction Box	1
Air Horns	2
Remote Controlled Headlight	3
Air Adjustable Suspension	4
Ignition System	5
Electronic Compass System	6
Trip Computer	7
Digital Fuel Injection (D.F.I.)	8
Instrument System	9
Audio System Operator's Manual	10
Component Layout, Function & Identification	11
Audio System Troubleshooting (Before You Begin)	12
No Sound from Radio or Cassette (Both)	13
No Sound from Cassette Deck (Only)	14
No Sound from Radio (Only)	15
Radio Difficulty	16
Radio Memory Malfunction	17
Intercom Difficulty	18
No Sound from CB (Only)	19
CB Difficulty	20
Wiring Diagrams & Component Schematics	21
Special Tools & Equipment	22

All rights reserved. No part of this publication may be reproduced, stored in a retrieval system, or transmitted in any form or by any means, electronic mechanical photocopying, recording or otherwise, without the prior written permission of Technical Services/Kawasaki Motors Corp., U.S.A. No liability can be accepted for any inaccuracies or omissions in this publication, although every possible care has been taken to make it as complete and accurate as possible. All procedures and specifications subject to change without prior notice or obligation. Illustrations in this publication are intended for reference use only and may not depict actual model component parts.

The junction box contains the following electrical components:

- Fuses
- Relays
- Diodes
- Accessory 2-Pin Connector

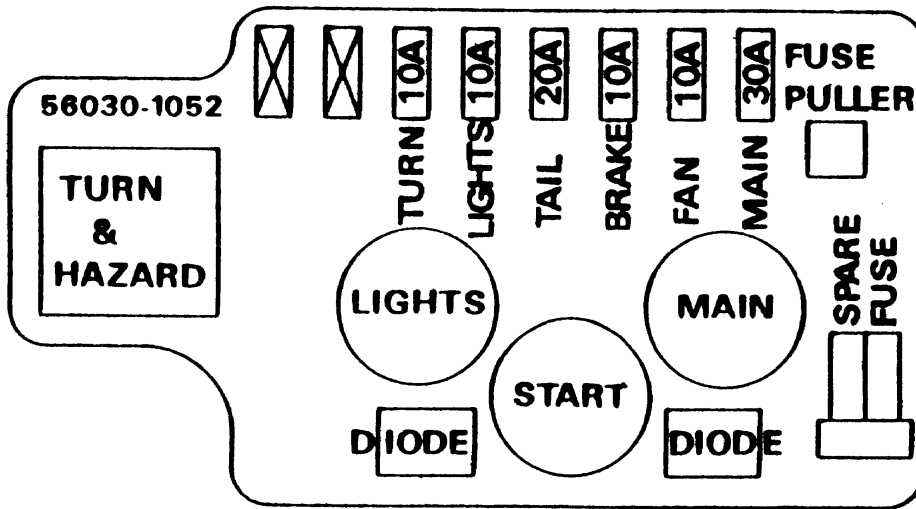
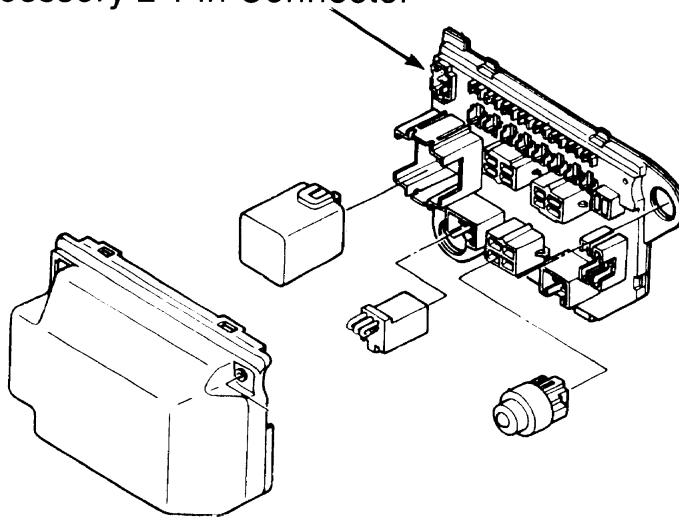

Two Ways To Start Engine

Transmission in gear and clutch lever in

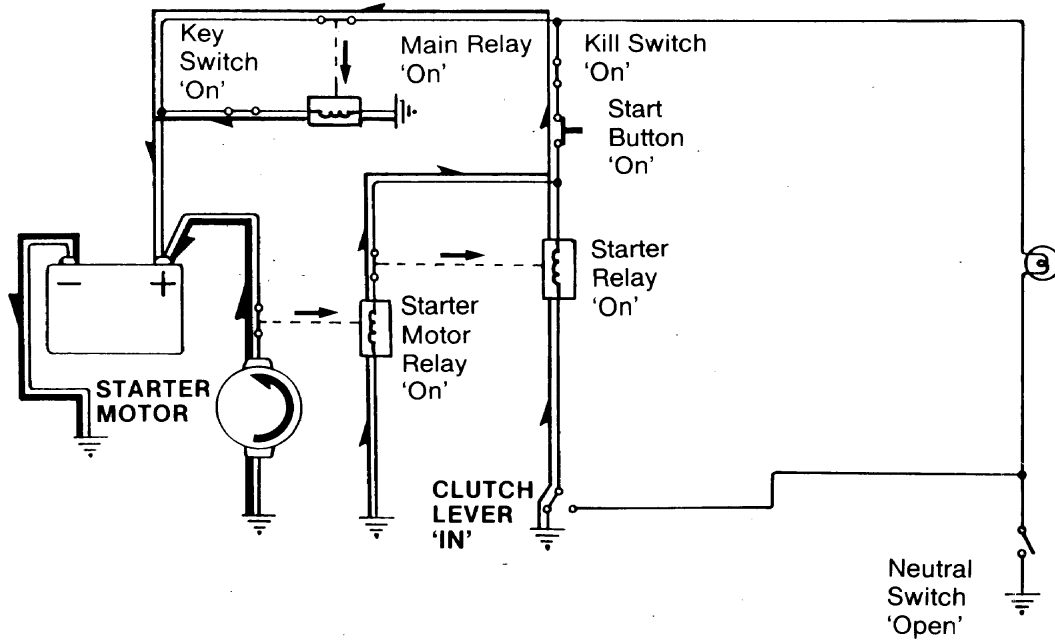

Transmission in neutral and clutch lever out

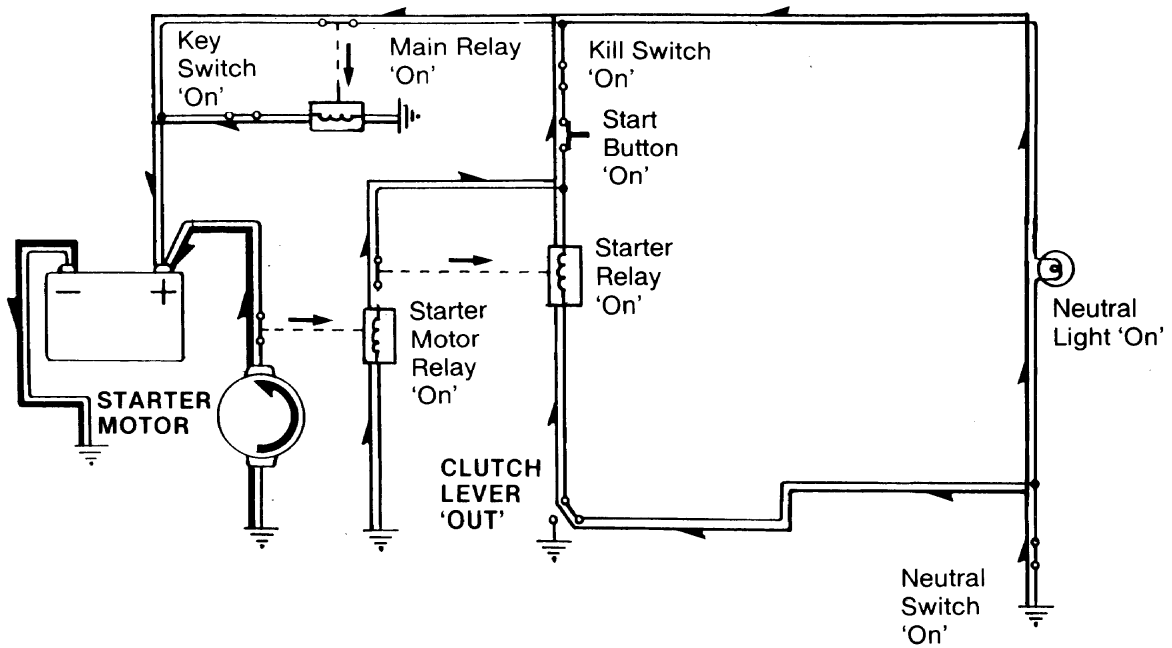

Headlight System

As start button is released the lighting relay is activated

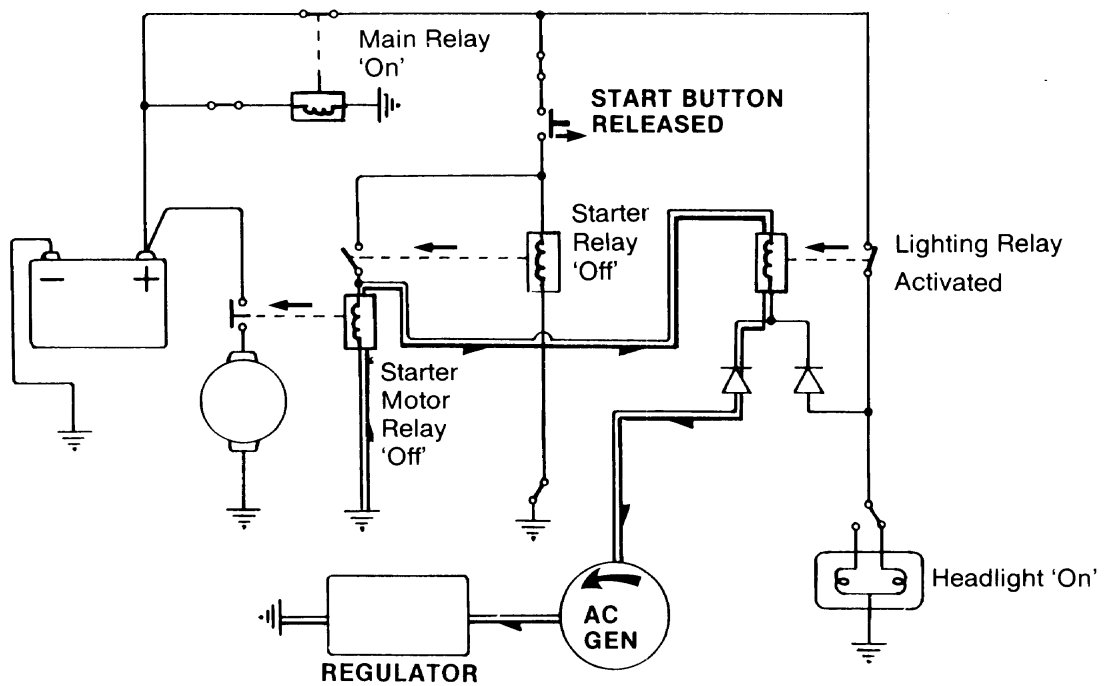

Headlight goes on automatically and lighting relay holds itself 'on'. Lighting relay receives ground when starter button is released, through the starter motor relay windings.

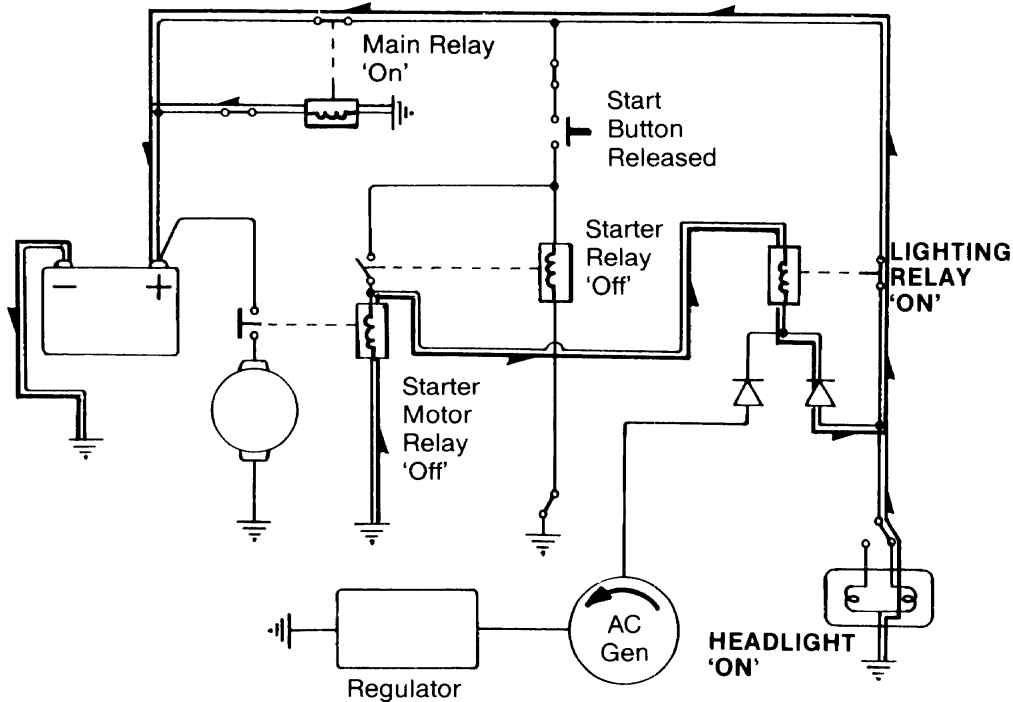

Junction Box Test

Junction Box Internal Circuit

- Remove the junction box from the motorcycle.
- Disconnect all the fuses, relays, diode assemblies, and connectors from the junction box.
- Make sure all connector terminals are clean, tight and none of them have been bent.
- ★ Clean the dirty terminals, and correct the bent terminals.
- Check conductivity of the internal circuit. Both terminals of the same number should conduct, and the differently numbered terminals should not conduct.
- ★ If there are open or short circuit, replace the junction box.

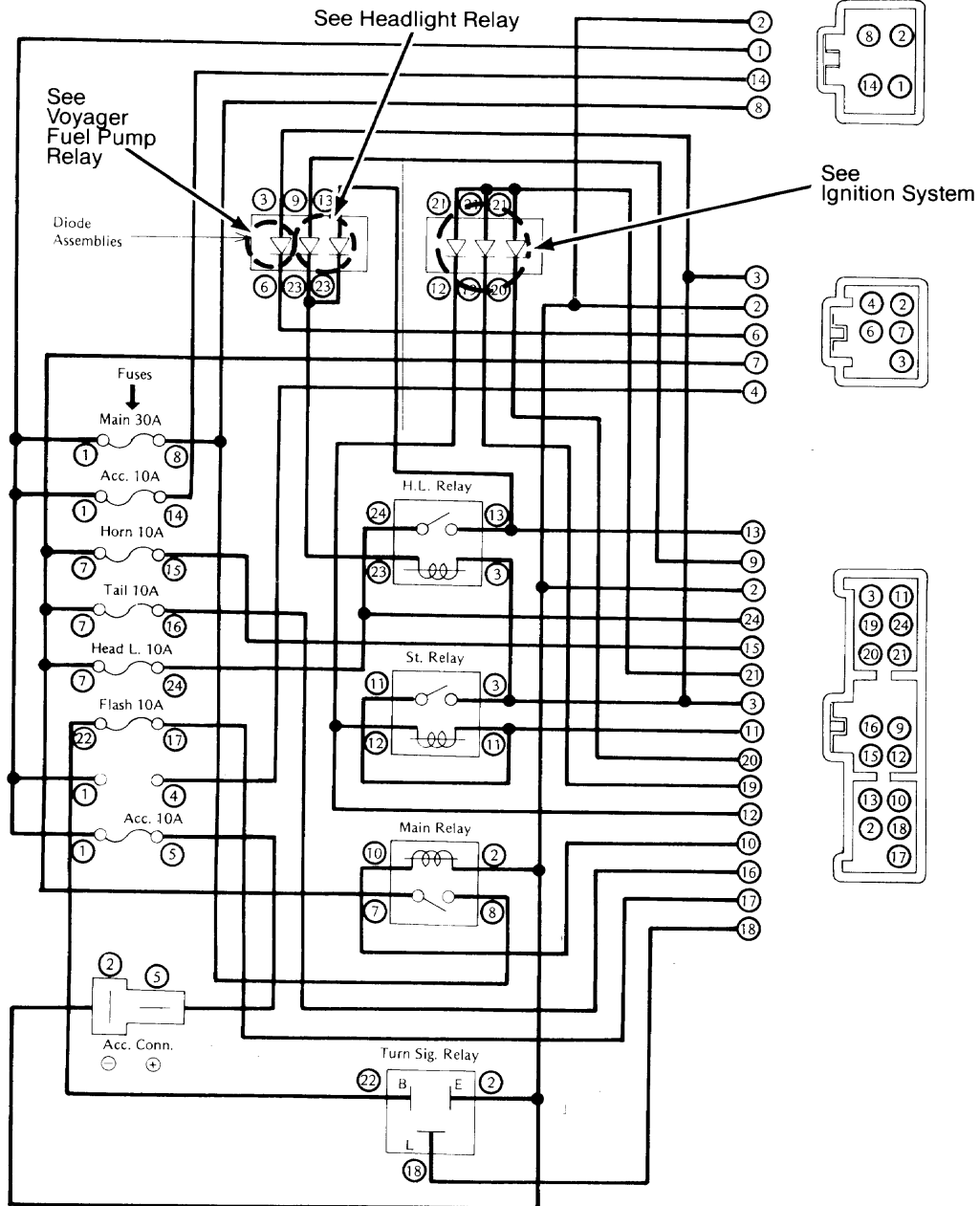

Diode and Turn Signal Relay Tests

(Example: Two lights are connected.)

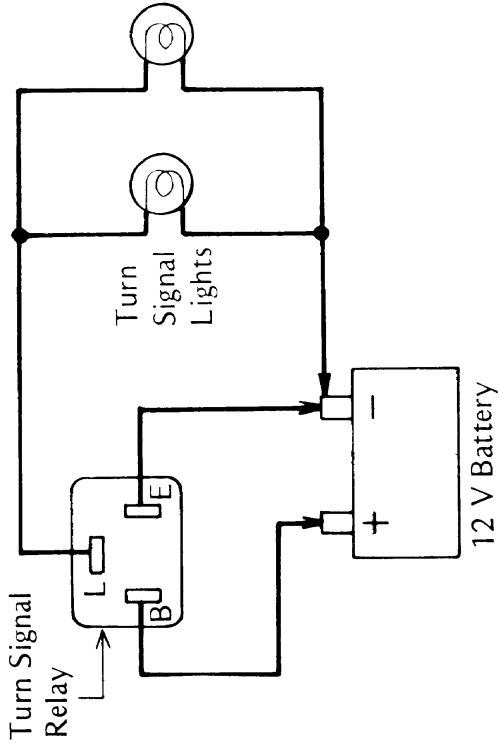

Testing Turn Signal Relay

The Number of Turn Signal Lights	Load		Flashes per Minute
	Wattage (W)		
1	21 - 23		More than 150
2	42 - 46		75 - 95
3	63 - 69		
4	84 - 92		

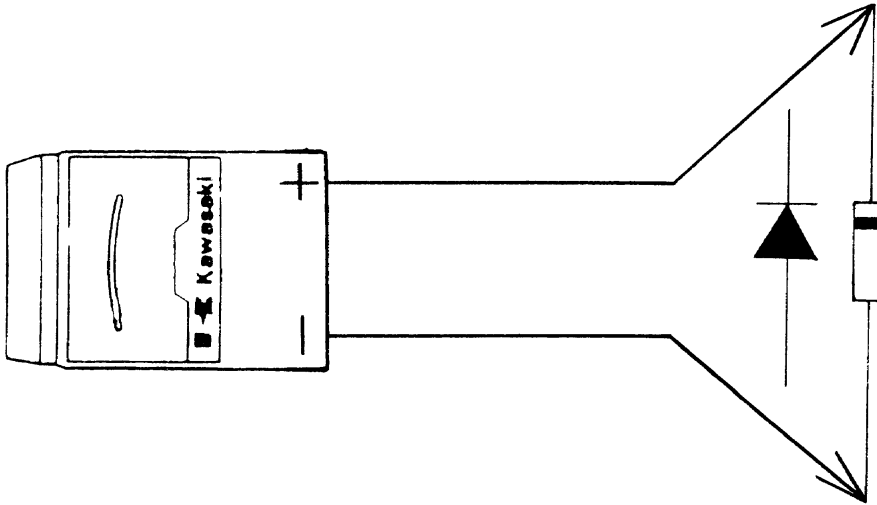

Diode Test

- Set meter to x 1K Ω range
- Connect meter to diode
- Meter should indicate low ohms
- Reverse meter leads on diode
- Meter should indicate infinity (∞) ohms

Relay and Fuse Tests

Main, Lighting and Starting Relay Tests

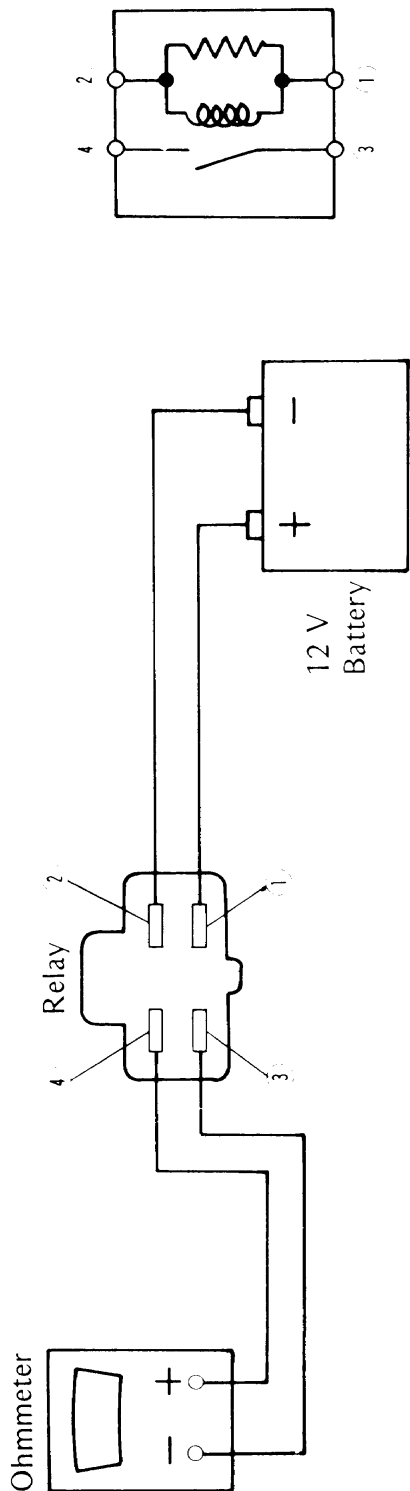

(1) and (2) : Relay Coil Terminals
 (3) and (4) : Relay Switch Terminals

Testing Relay

Meter range:	x 1 Ω range
Criteria:	
When battery is connected	$\rightarrow 0 \Omega$
When battery is disconnected	$\rightarrow \infty \Omega$

Inspecting Fuses

- Remove the fuse from the junction box.
- Inspect the fuse element for blowout.
- ★ If it has been blown out, replace the fuse.

Fuse

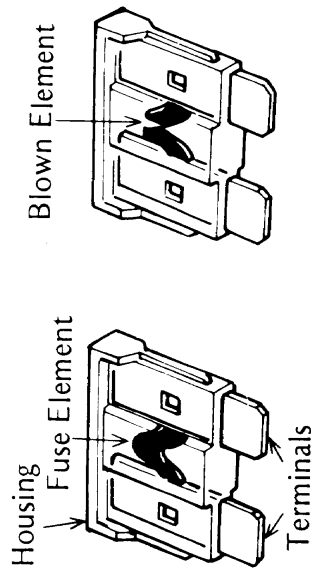

- Dual air horns
- Self-contained system

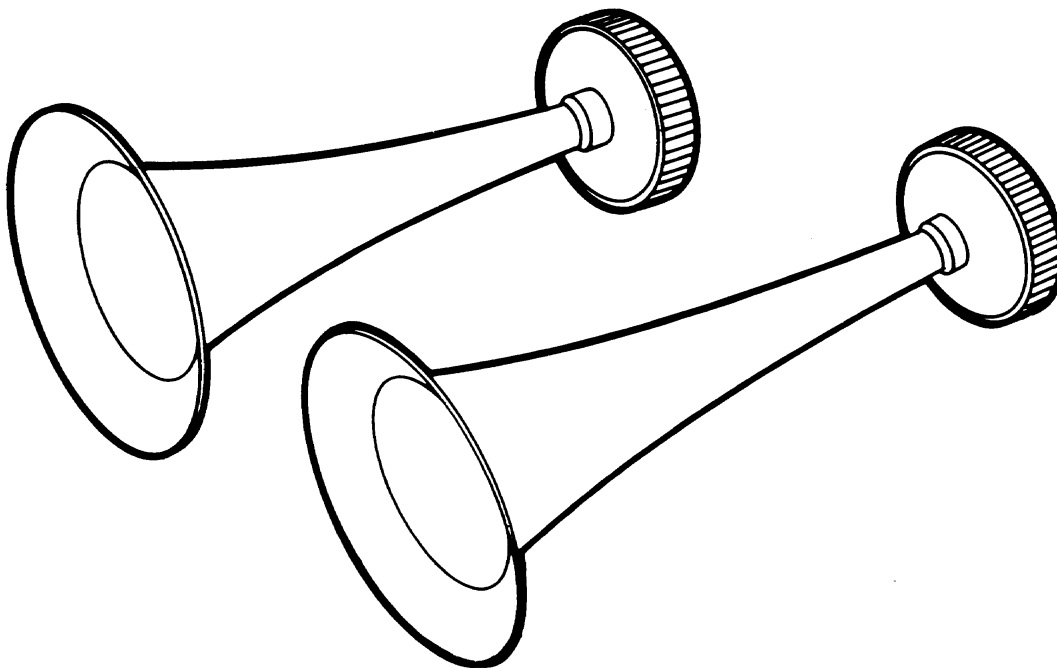

Air Horn System

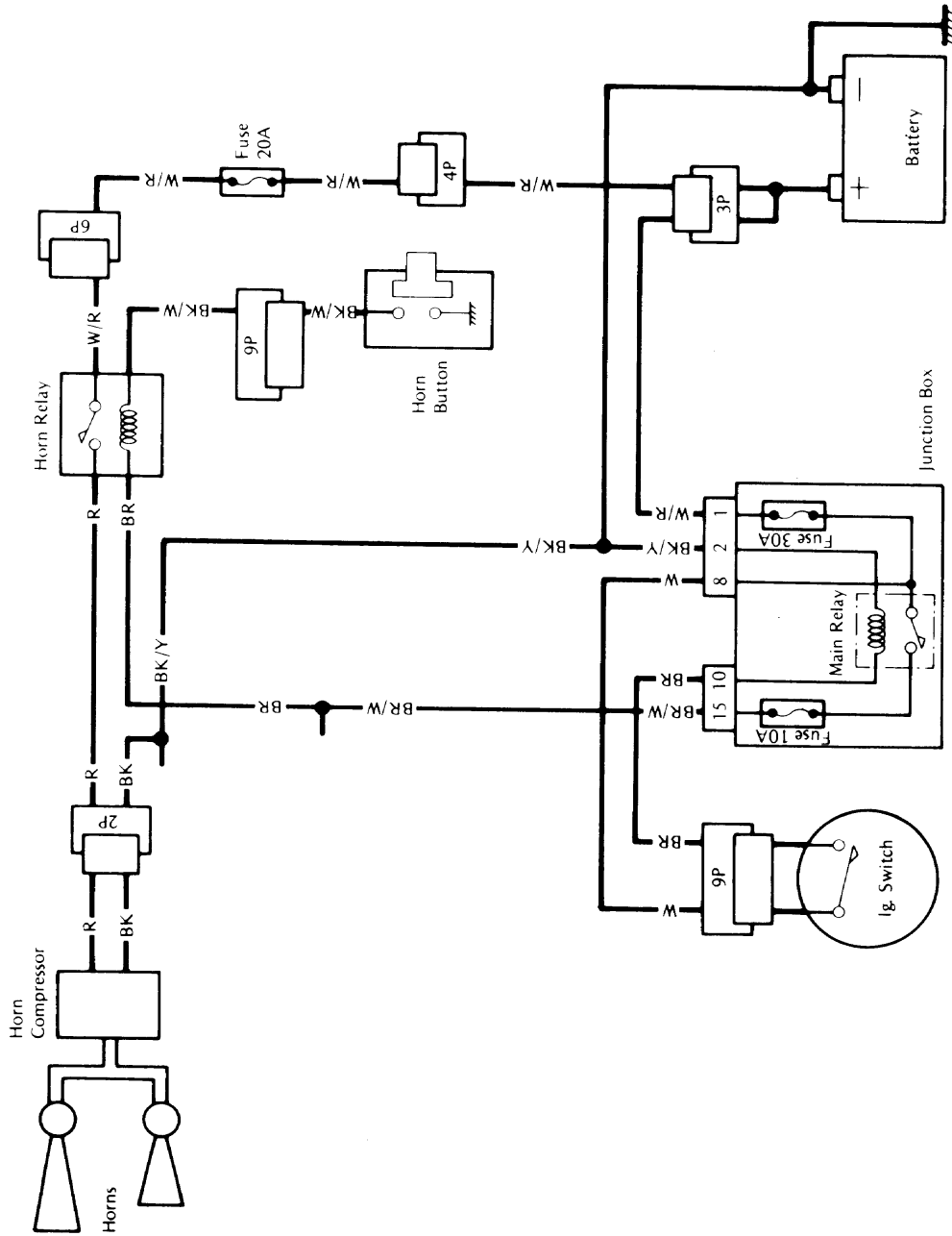

Horn Compressor Test

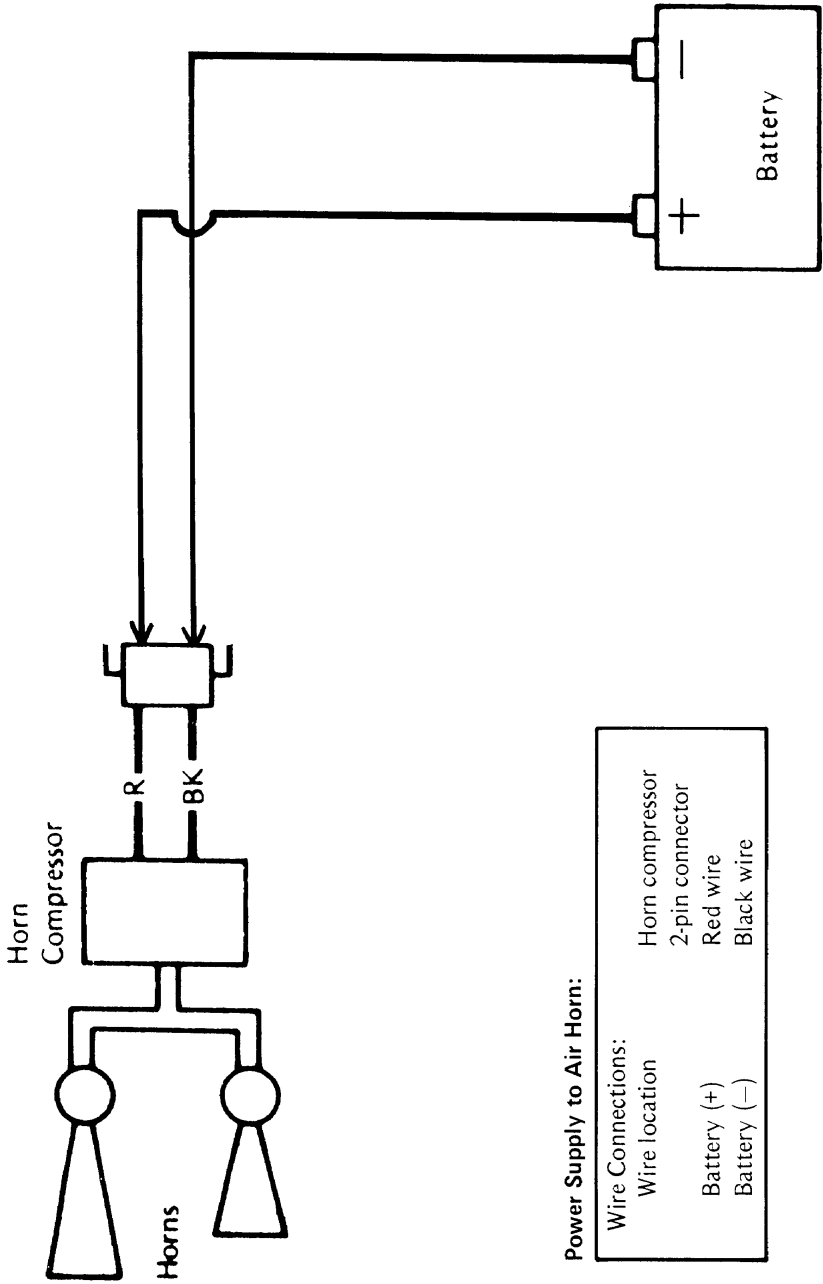

Power Supply to Air Horn:

Wire Connections:	
Wire location	Horn compressor
Battery (+)	2-pin connector
Battery (-)	Red wire
	Black wire

Horn Power Supply Test

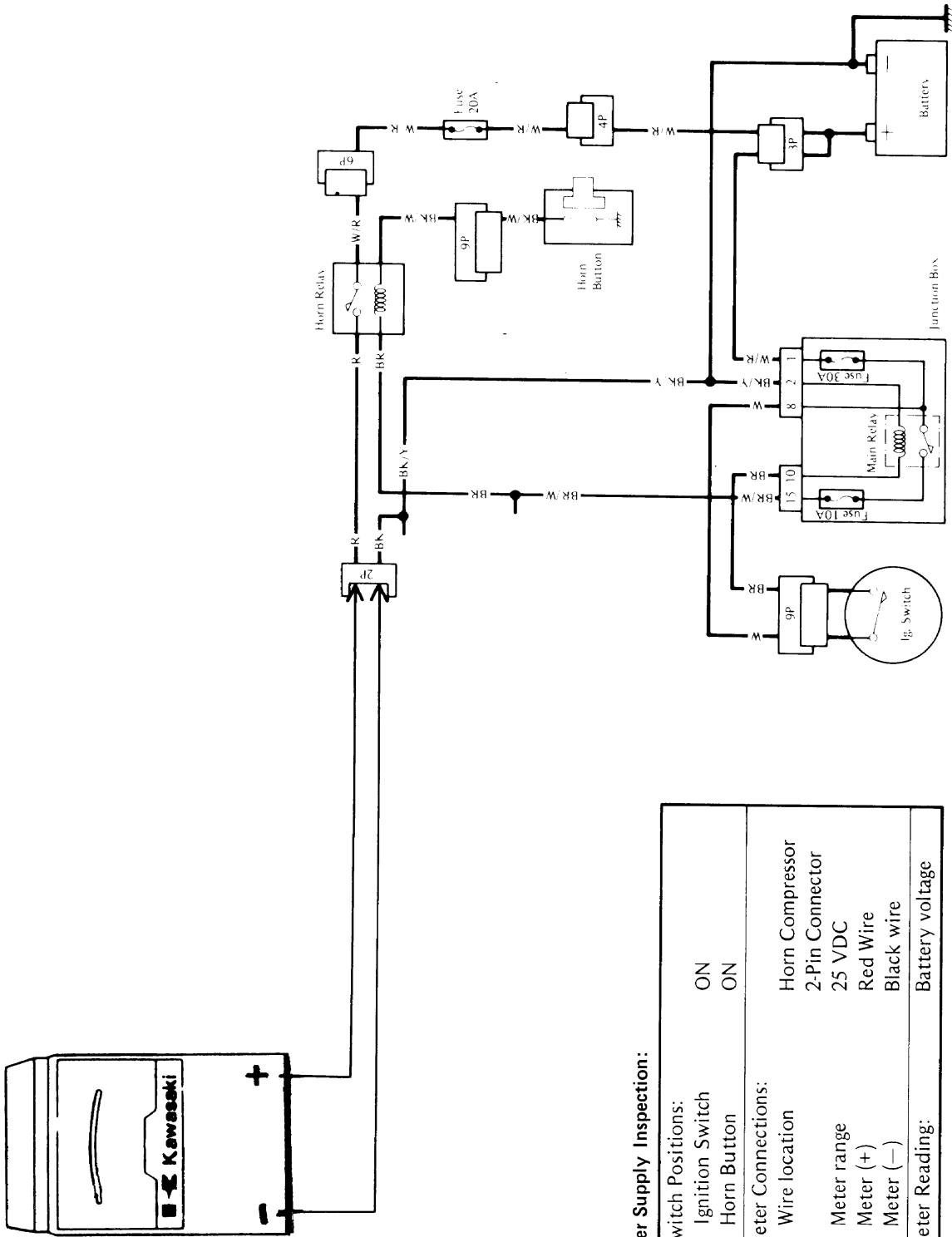

Power Supply Inspection:

Switch Positions:	ON
Ignition Switch	ON
Horn Button	ON
Meter Connections:	Horn Compressor
Wire location	2-Pin Connector
Meter range	25 VDC
Meter (+)	Red wire
Meter (-)	Black wire
Meter Reading:	Battery voltage

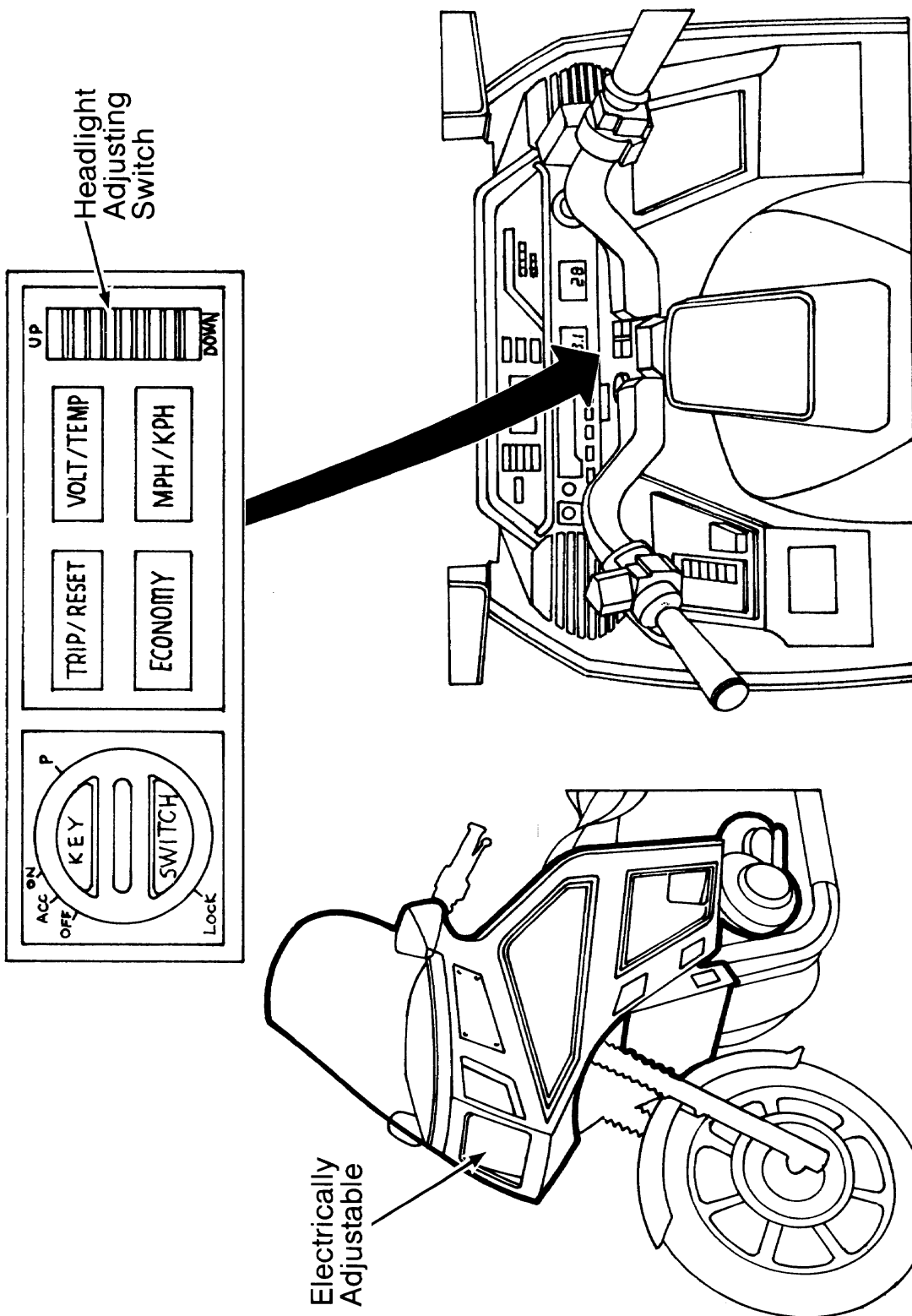

Headlight System

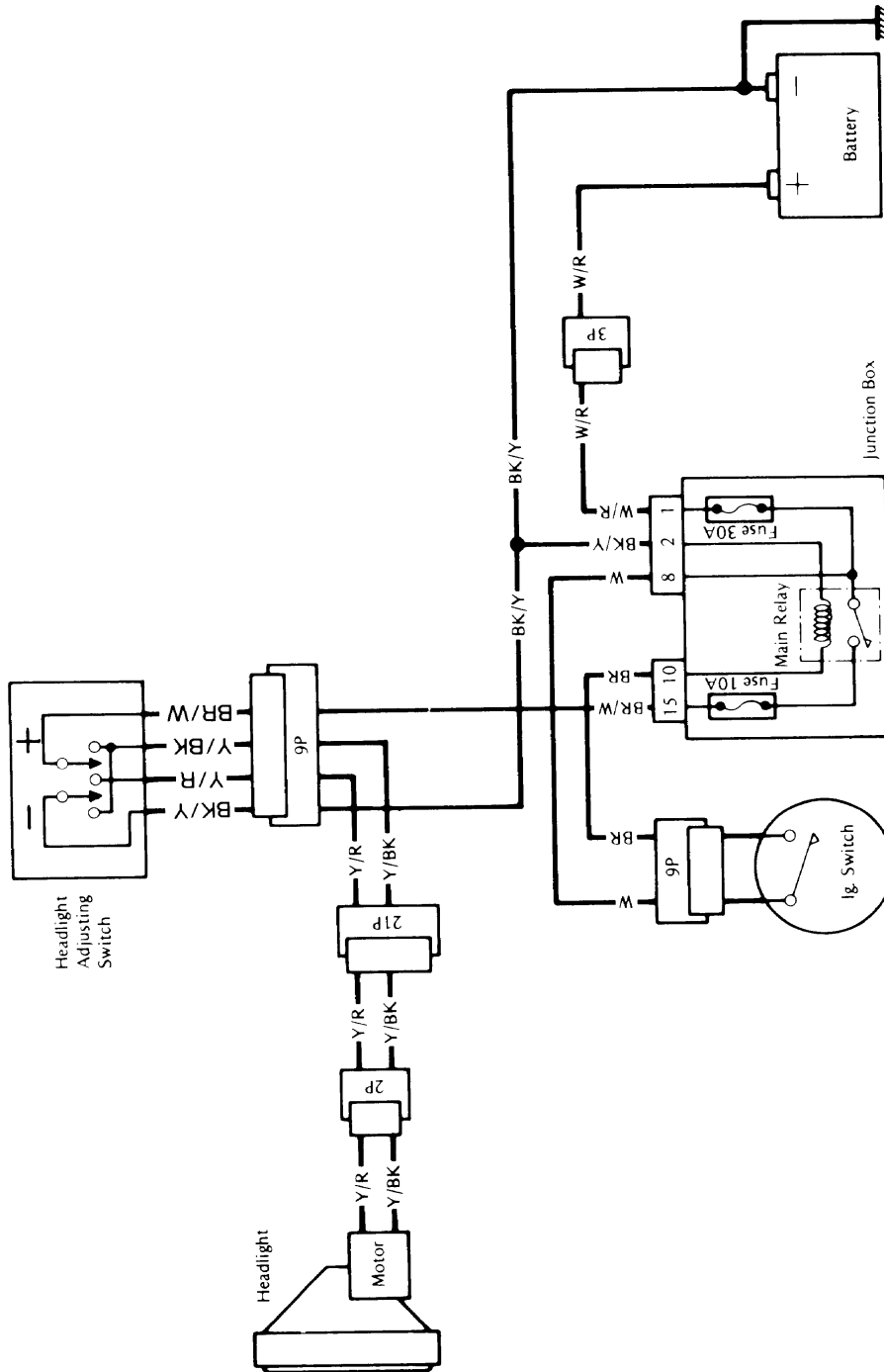

Motor Test

Headlight Down

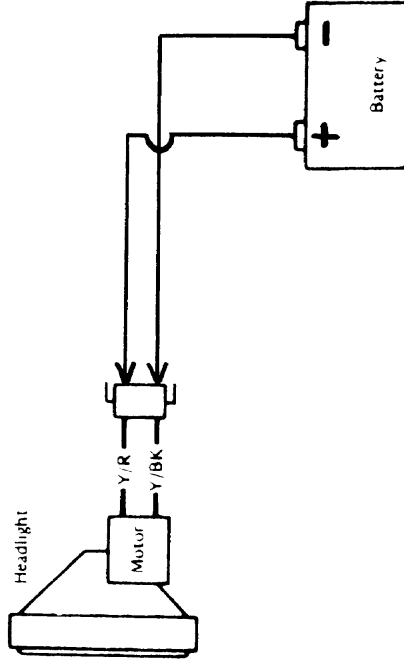

Headlight Up

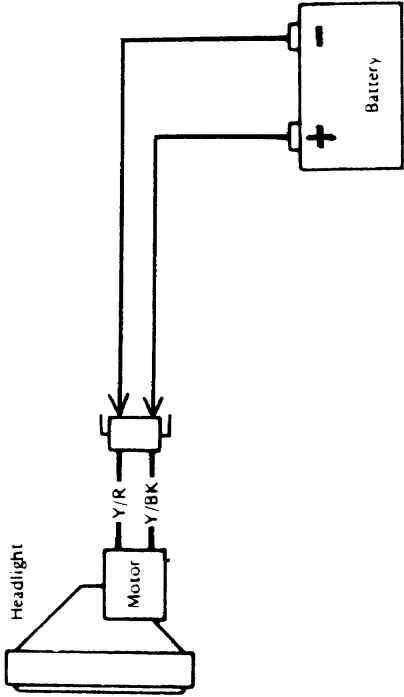

Voltage Test — Down

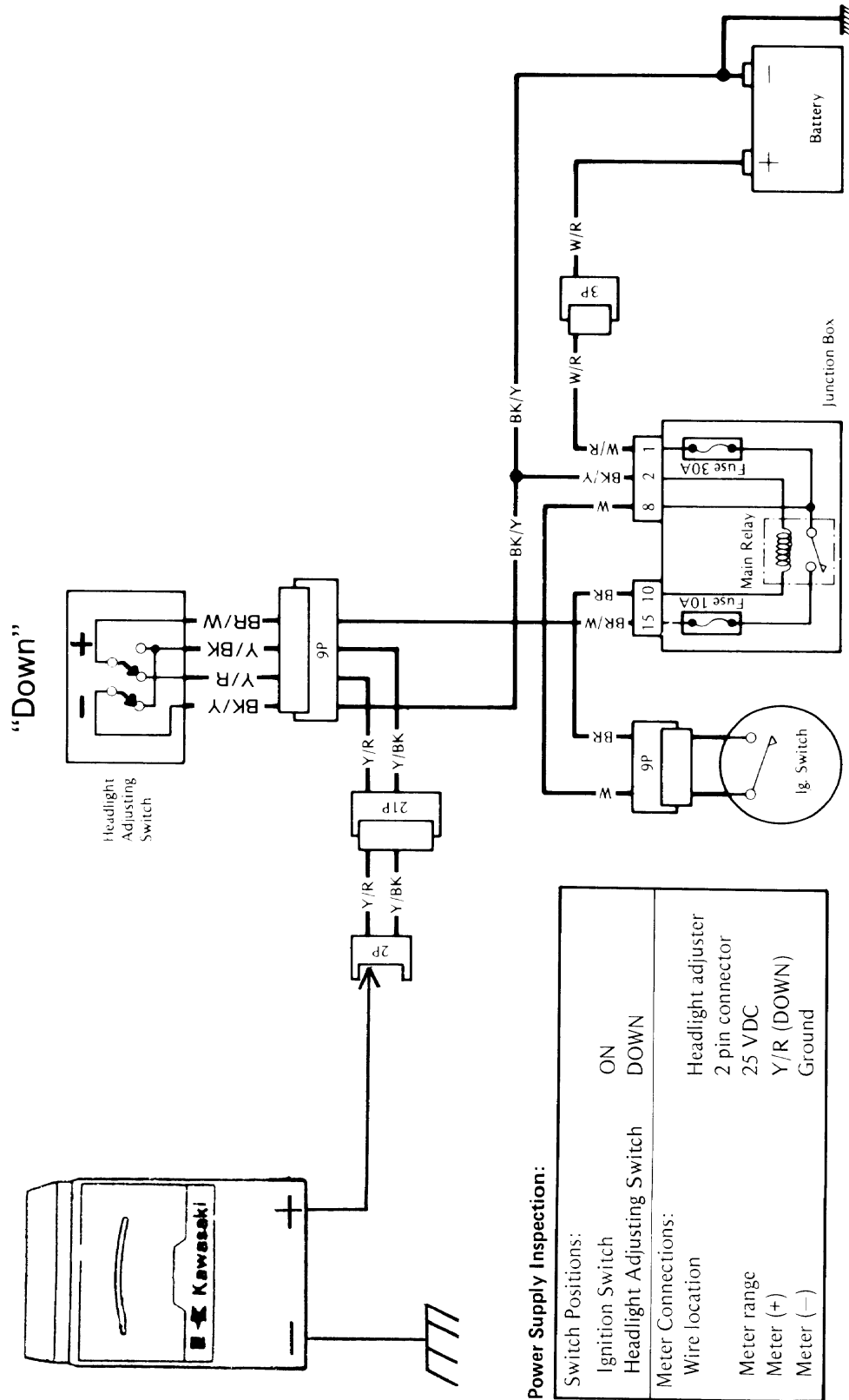

Power Supply Inspection:

Switch Positions:	ON	DOWN
Ignition Switch		
Headlight Adjusting Switch		
Meter Connections:		
Wire location	Headlight adjuster	
Meter range	2 pin connector	
Meter (+)	25 VDC	
Meter (-)	Y/R (DOWN)	
	Ground	

Switch Tests

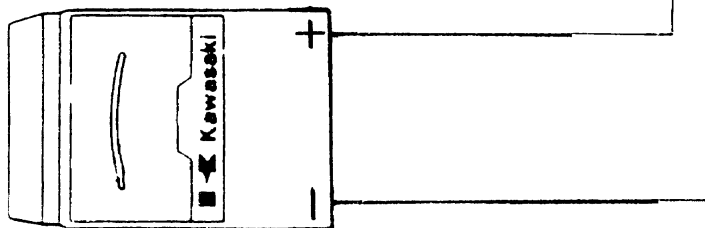
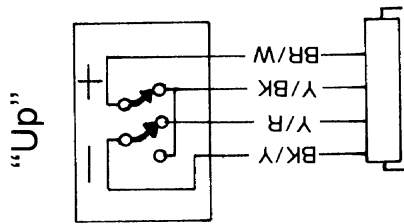
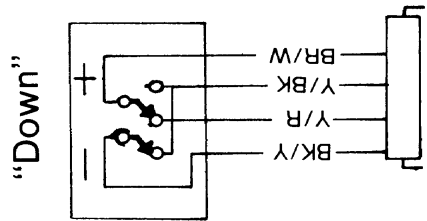

Headlight Adjusting Switch Operation:

Ignition Switch Position:	OFF					
Meter Connections:	Female headlight adjusting switch connector (disconnected)					
Wire location	x 1 Ω					
Meter range						
Headlight Adjusting Switch Position:	UP			DOWN		
One meter wire \rightarrow	BR/W	Y/R	BR/W	Y/BK	Y/R	Y/BK
Other meter wire \rightarrow	Y/BK	BK/Y	Y/R	BK/Y	BK/Y	BK/Y
Meter Reading:	0 Ω	0 Ω	$\infty \Omega$	0 Ω	$\infty \Omega$	$\infty \Omega$
Headlight Adjusting Switch Position:						
One meter wire \rightarrow	BR/W	Y/BK	BR/W	Y/R	Y/R	Y/R
Other meter wire \rightarrow	Y/R	BK/Y	Y/BK	BK/Y	BK/Y	BK/Y
Meter Reading:	0 Ω	0 Ω	$\infty \Omega$	0 Ω	$\infty \Omega$	$\infty \Omega$

- Transmission in NEUTRAL and key ON
- Can exceed 75 P.S.I.
- On-board air compressor

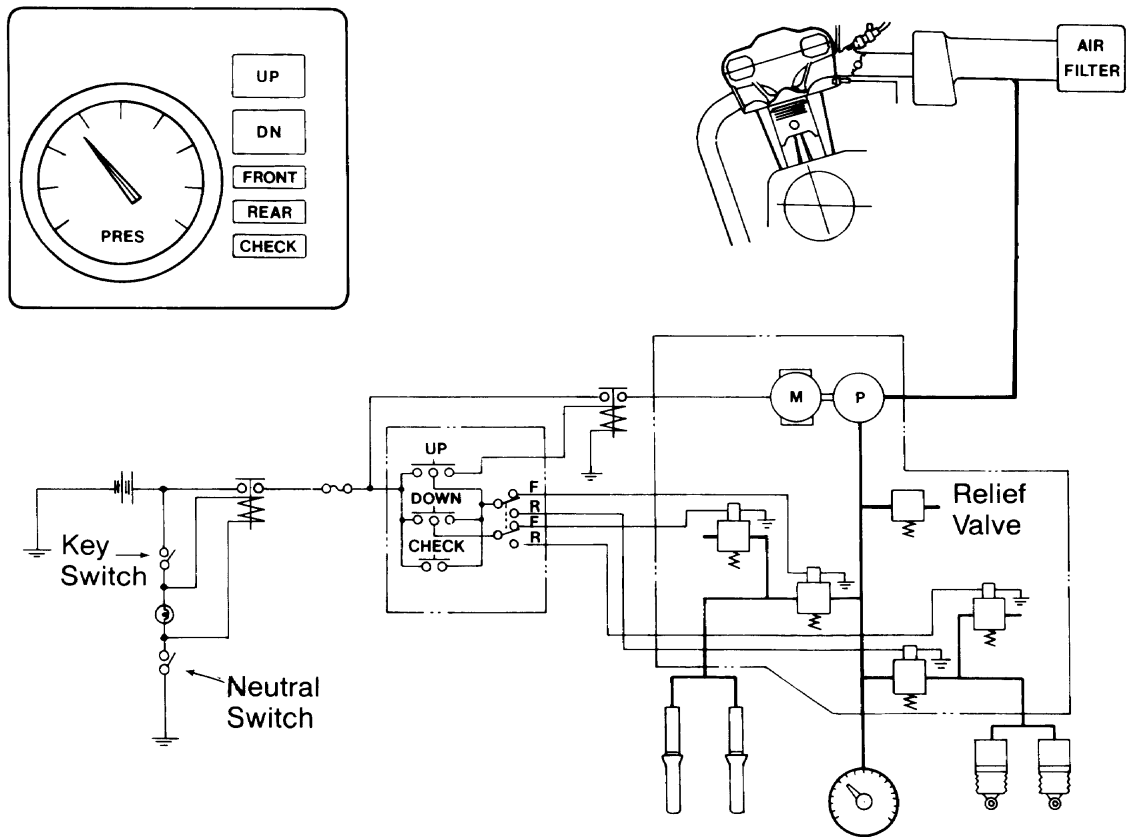

Air Suspension System

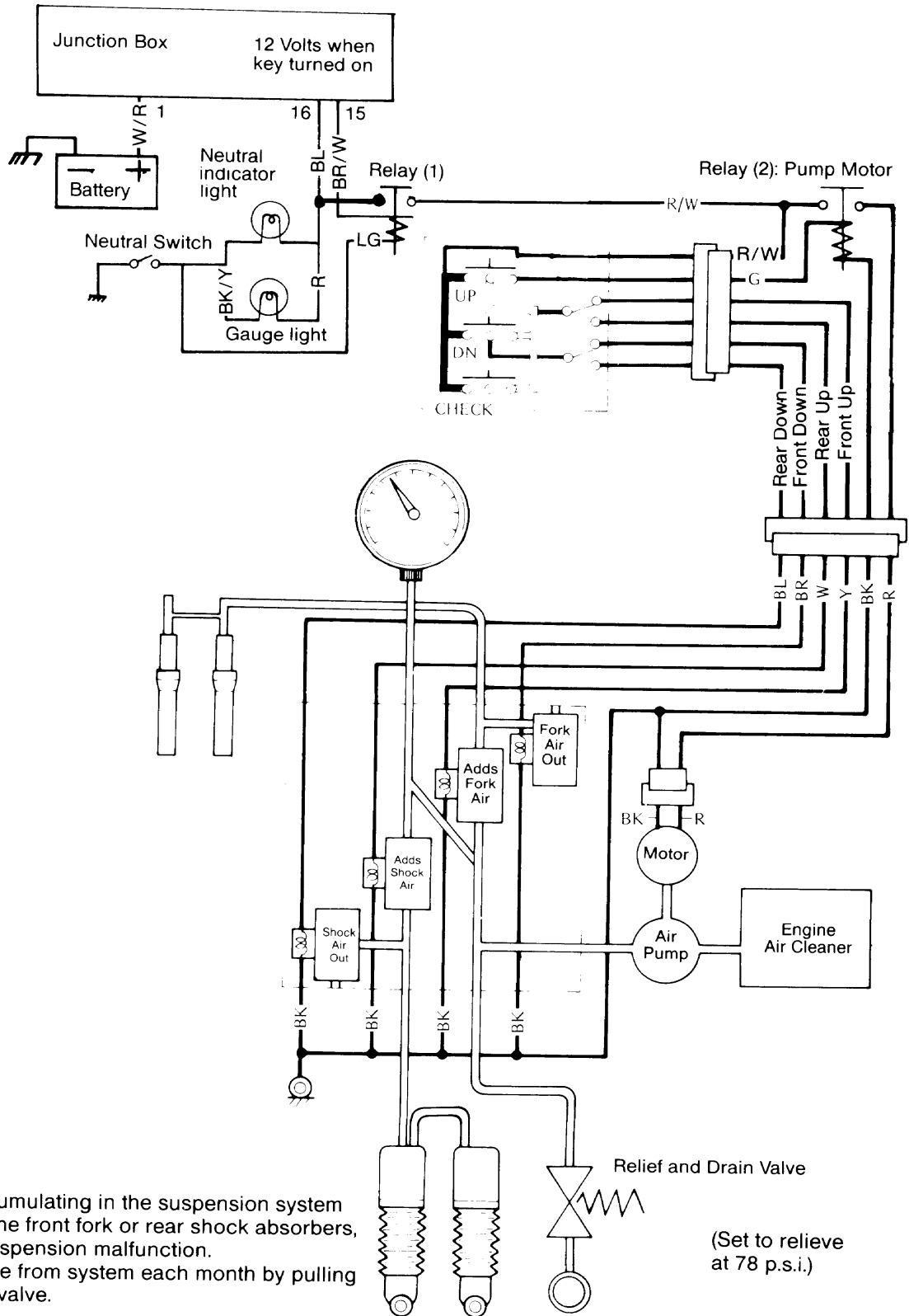

NOTE:

- Moisture accumulating in the suspension system can get into the front fork or rear shock absorbers, and cause suspension malfunction.
- Drain moisture from system each month by pulling ring on relief valve.

(Set to relieve at 78 p.s.i.)

Air Pump and Motor Test

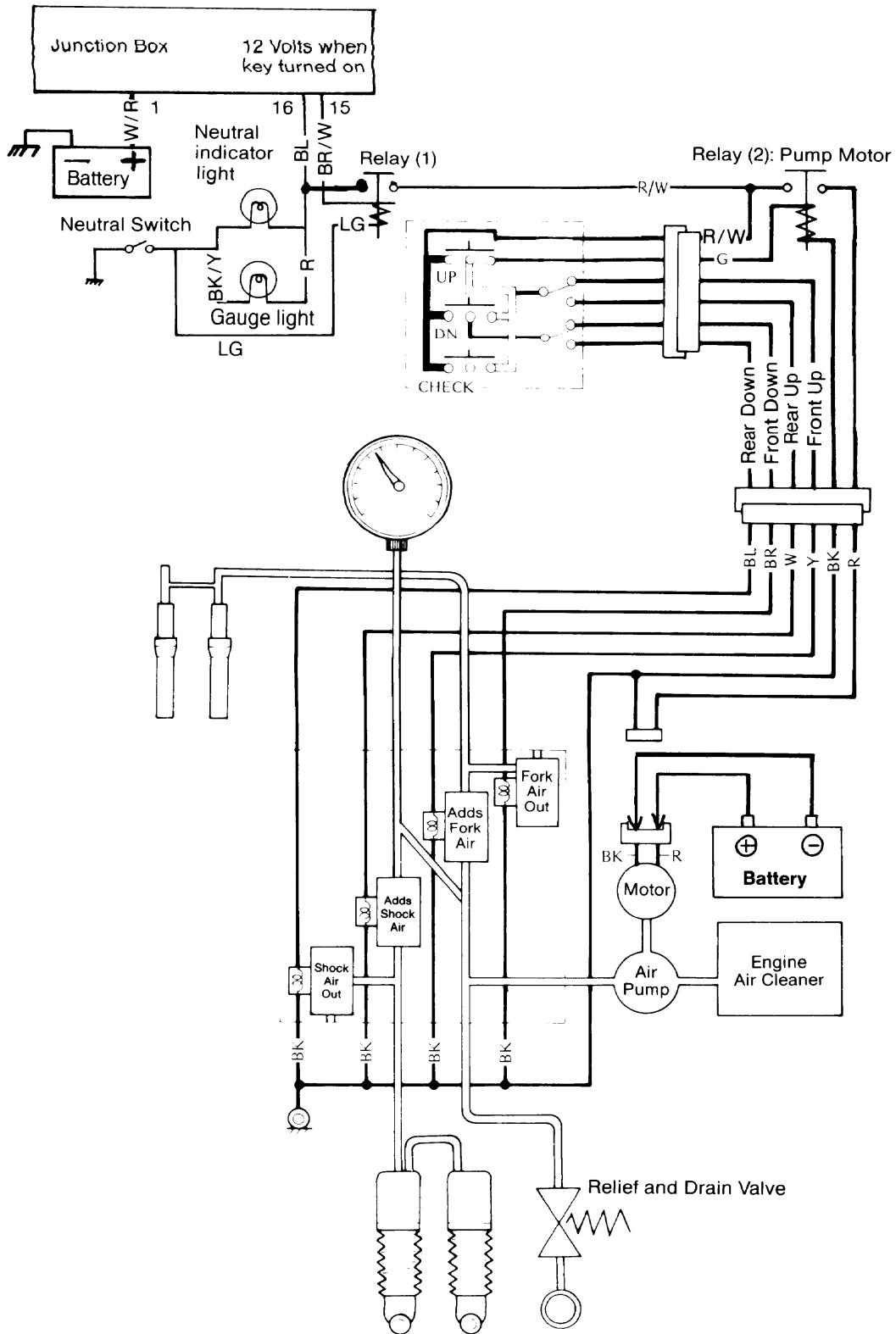

Air Valve Solenoid Tests

Solenoid Valve Resistance

Meter Range:	x 1 Ω
Connections:	BL — Ground lead (BK) BR — Ground lead (BK) W — Ground lead (BK) Y — Ground lead (BK)
Reading:	7 — 8.5 Ω (all)

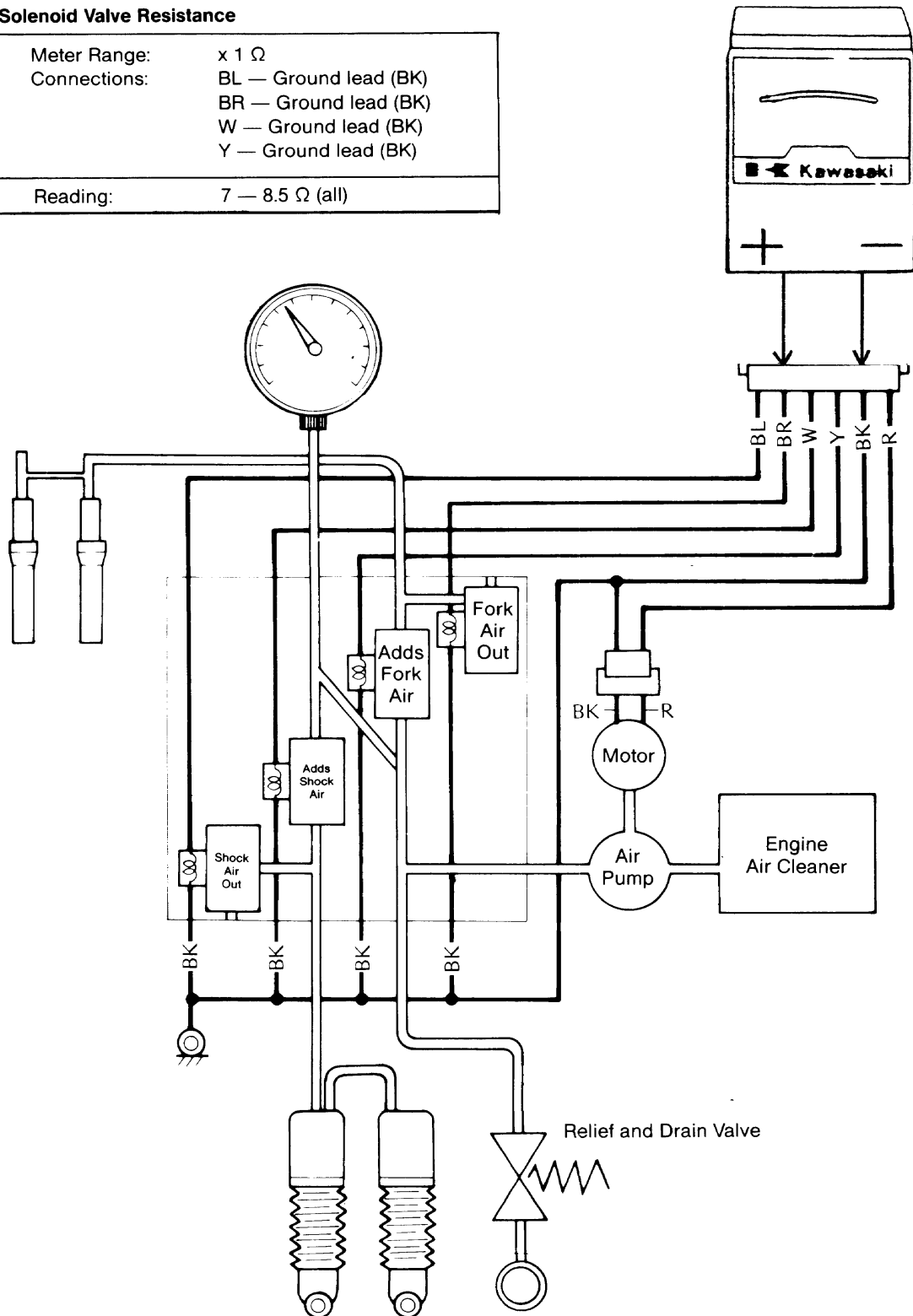

Suspension Switch Tests

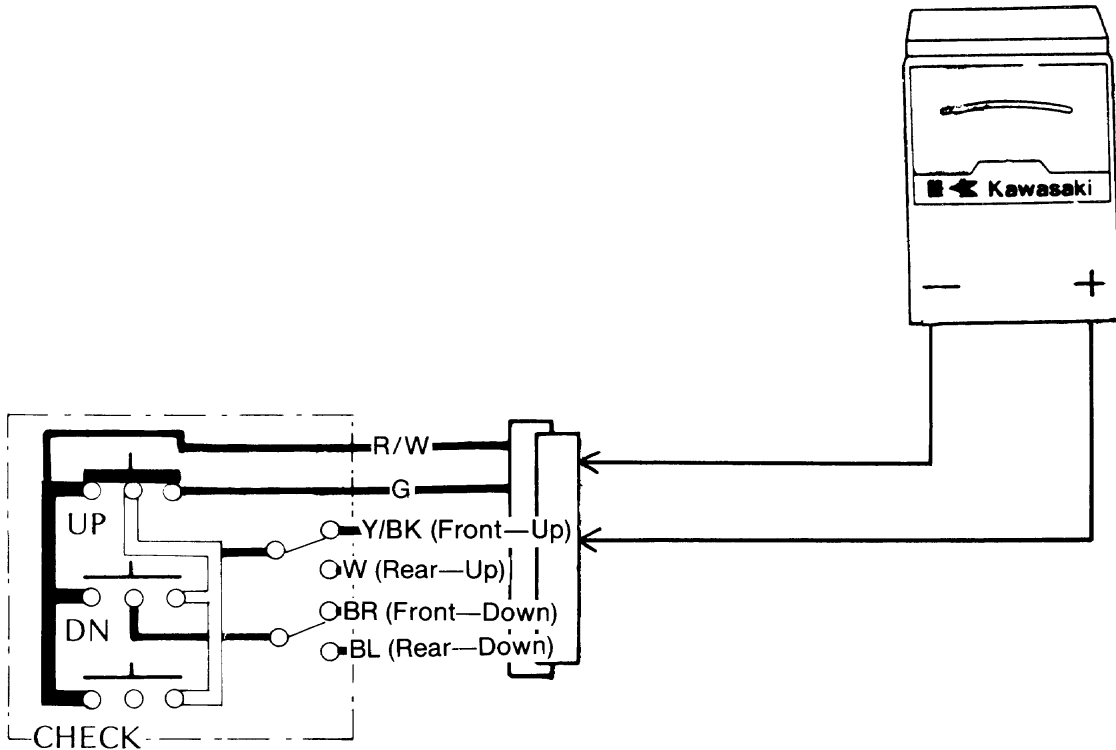

Meter Range: x 1 Ω
 Meter Reading: 0 Ω between wire colors indicated

Suspension Switch Connections

Button		Lead Color					
		R/W	G	Y/BK	BR	W	BL
UP	FRONT	●	●	●			
	REAR	●	●			●	
DOWN	FRONT	●		●	●		
	REAR	●				●	●
CHECK	FRONT	●		●			
	REAR	●				●	

Leakage Inspection

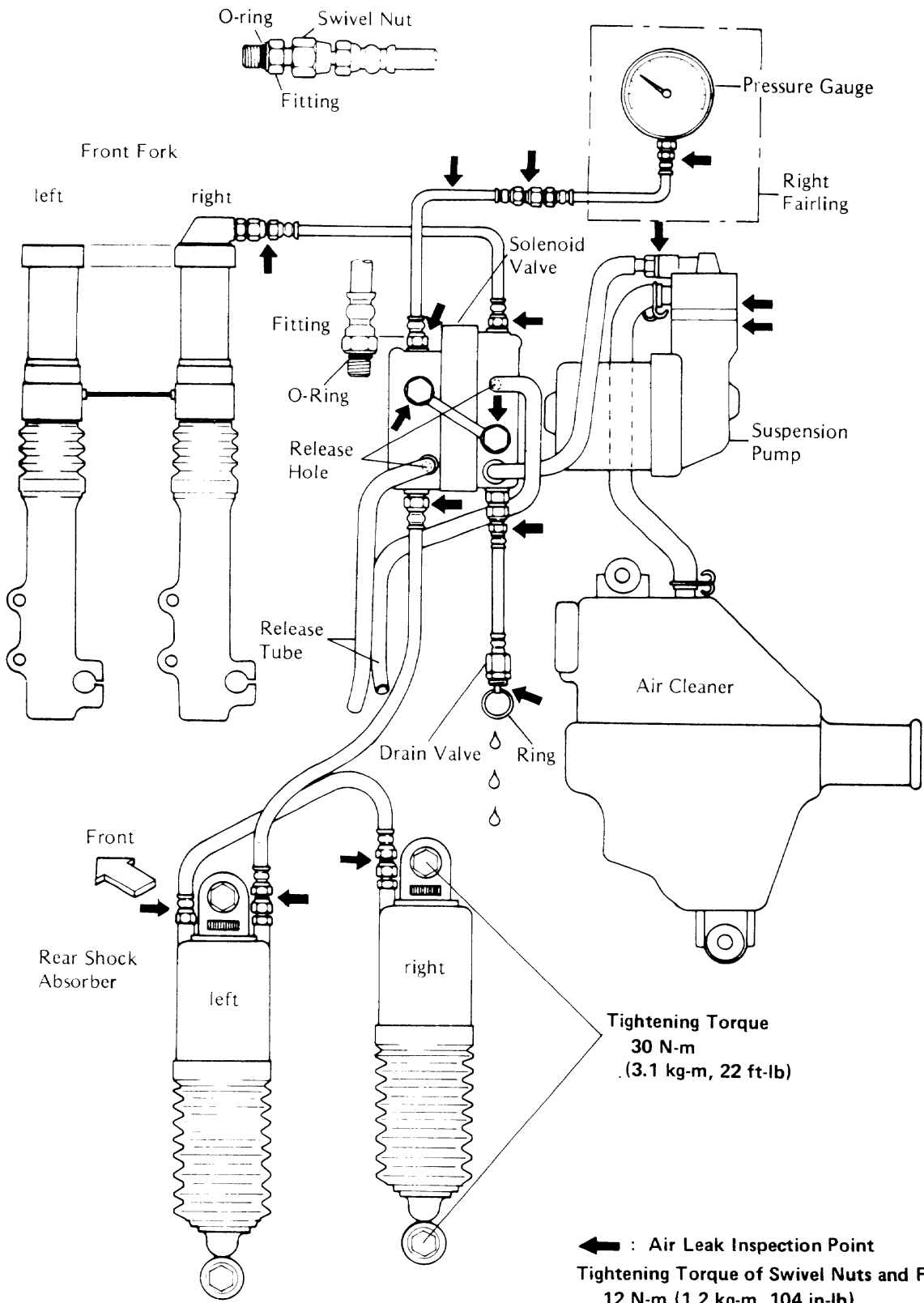

NOTE: The BK/W wire of the igniter must be connected to ground () for the ignition system to operate. The igniter is grounded through the diodes of the sidestand, starter lockout or neutral switch circuits located in the Junction Box.

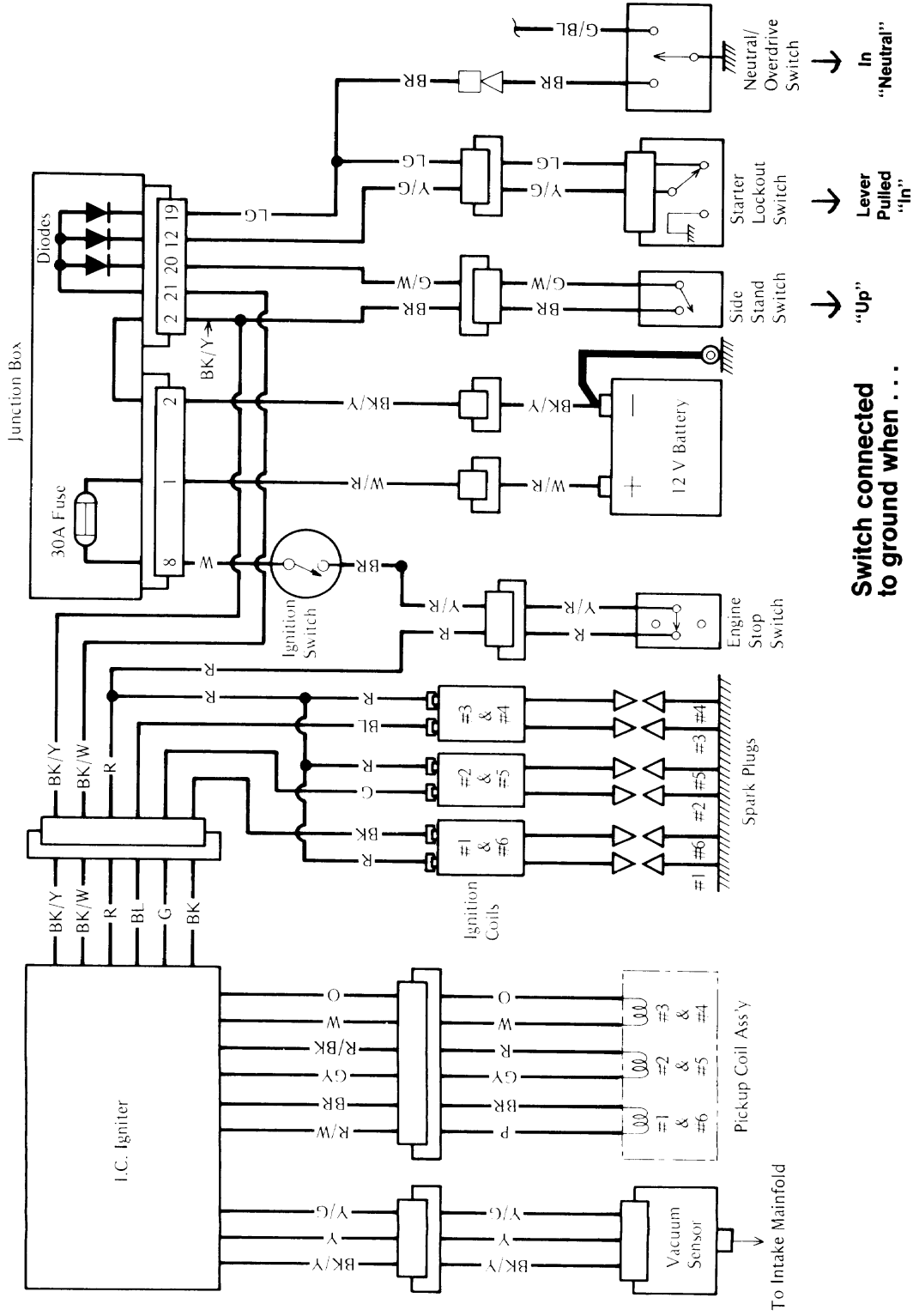

Ignition System Operation

Ignition System

Introduction:

This model employs a transistorized ignition system with a vacuum advance system. Since this ignition system has no moving mechanical parts to wear out, no maintenance is required. The vacuum advance system utilizes the vacuum in the intake manifold. Under part throttle operation, the intake manifold vacuum is high and, therefore, a smaller amount of mixture is drawn into the engine and compression pressure is relatively low. With low pressure, the mixture does not burn as rapidly, and to obtain maximum efficiency under such conditions, the spark should be more advanced. This additional advance is obtained by means of the vacuum advance system. The current for the ignition coil primary circuit is controlled by use of an electronic switch called a power transistor in the IC igniter. Each spark plug fires every time the piston rises. Although the spark jumps across the electrodes during the exhaust stroke, it has no effect on engine operation since there is no compression and no fuel to burn.

Main Components:

Pickup Coil Assembly:

The pickup coil is a magnetic signal generator which consists of a permanent magnet and coil. Every time the projection on the alternator rotor passes under the pickup coil core, signals are generated and sent to the IC igniter.

IC Igniter:

The IC igniter has the following functions.

(1) Electronic Ignition Timing Advance

The timing control circuit is provided in the IC igniter, and the ignition timing is controlled electronically in order to obtain efficient operation throughout the range of engine speed and load (intake vacuum).

(2) Time-controlled Primary Current Cut Off

If the ignition switch is left turned on but the engine is not running, the primary current may continue to flow through a certain ignition coil (depending on the crankshaft position). If this condition continues, the battery will be discharged, and the ignition coil and the power transistor will be damaged by overheating. To prevent such problems, the primary current is automatically cut off a few seconds after the engine stops. However, once the engine is turned over and the first signal from the pickup coil arrives at the igniter, the primary current again flows.

(3) Dwell Angle Control

The dwell angle is electronically controlled by the dwell angle control circuit so that it increases as the engine speed increases. This is to save the electric power at low engine speed, and to produce a spark of sufficient strength at high engine speed.

(4) Voltage Regulation

A voltage regulating circuit is incorporated in the circuitry. The voltage regulating circuit supplies an even voltage to the other circuits in the igniter despite variations in the battery voltage. As a result, stable operation of the igniter is ensured. Moreover, the voltage regulating circuit protects the circuitry from surge currents in the power lines.

Ignition Coil:

Every time both pistons rise, the ignition coil fires both spark plugs simultaneously which are connected in series. The polarity of the two spark plug leads are as shown in the figure when the primary wires are connected as indicated on the ignition coil body.

Polarity of Ignition Coil

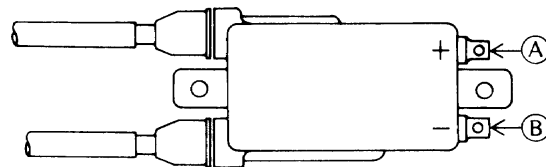

(A) : Connect Red Wire

(B) : Connect Black, Blue or Green Wire

1. Spark Plug Lead
2. Ignition Coil
3. Marking
4. Primary + Terminal
5. Primary - Terminal

Vacuum Sensor:

The vacuum sensor detects intake vacuum from the engine and provides voltage to the IC igniter in proportion to the intake vacuum. The vacuum sensor consists of a semiconductor type pressure sensor and an output signal amplifier.

Safety Instructions:

There are a number of important precautions that must be observed when servicing the transistorized ignition system. Failure to observe these precautions can result in serious system damage. Learn and observe all the rules listed below.

(1) Because of limited capacity of the voltage regulating circuit in the IC igniter, do not disconnect the battery leads or any other electrical connections when the ignition switch is in the "ON" or "ACC" position. This is to prevent IC igniter damage.

(2) Do not install the battery backwards. The negative side is grounded. This is to prevent damage to the diodes and IC igniter.

Igniter Unit Circuits

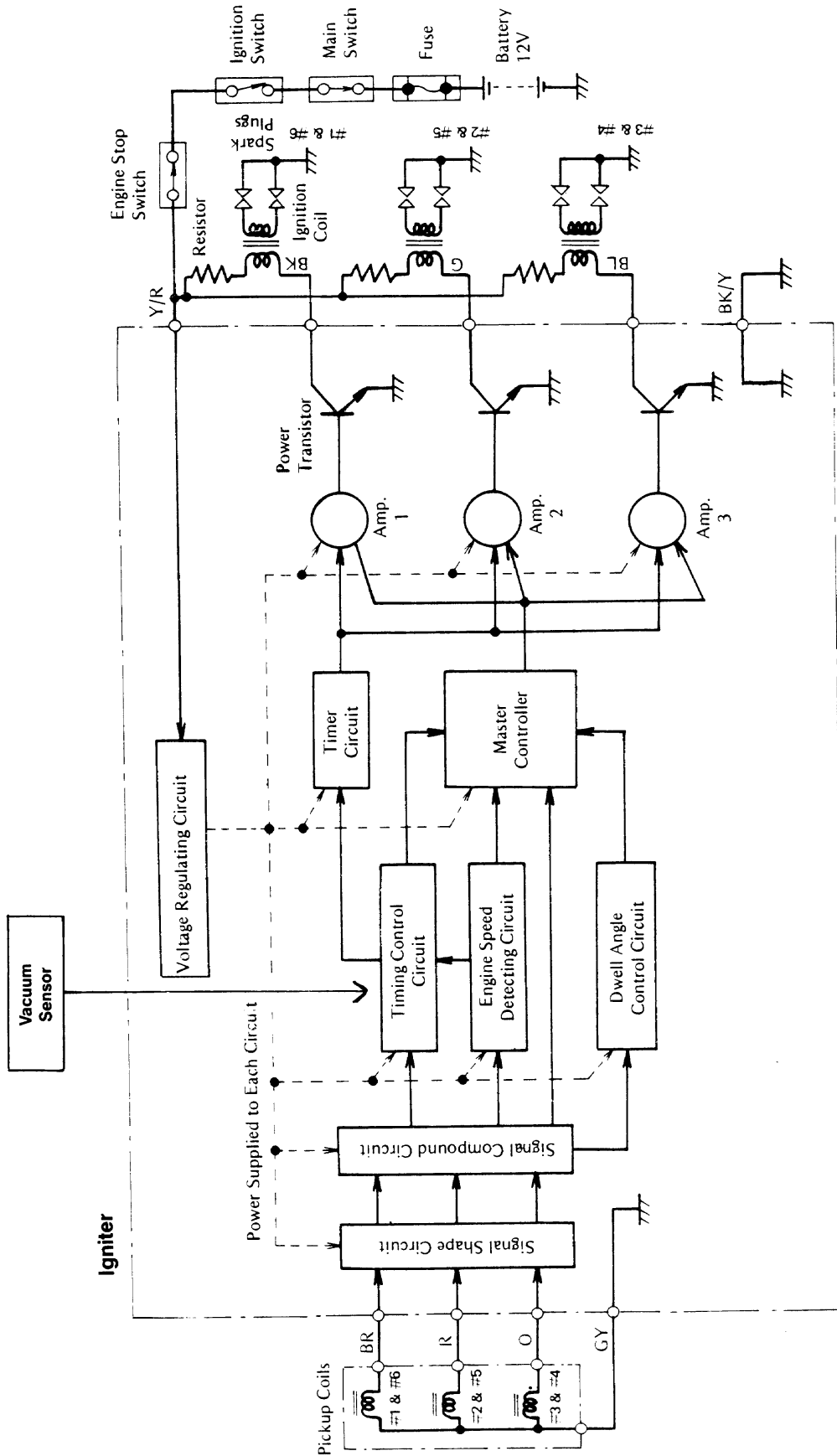

Ignition Timing Check

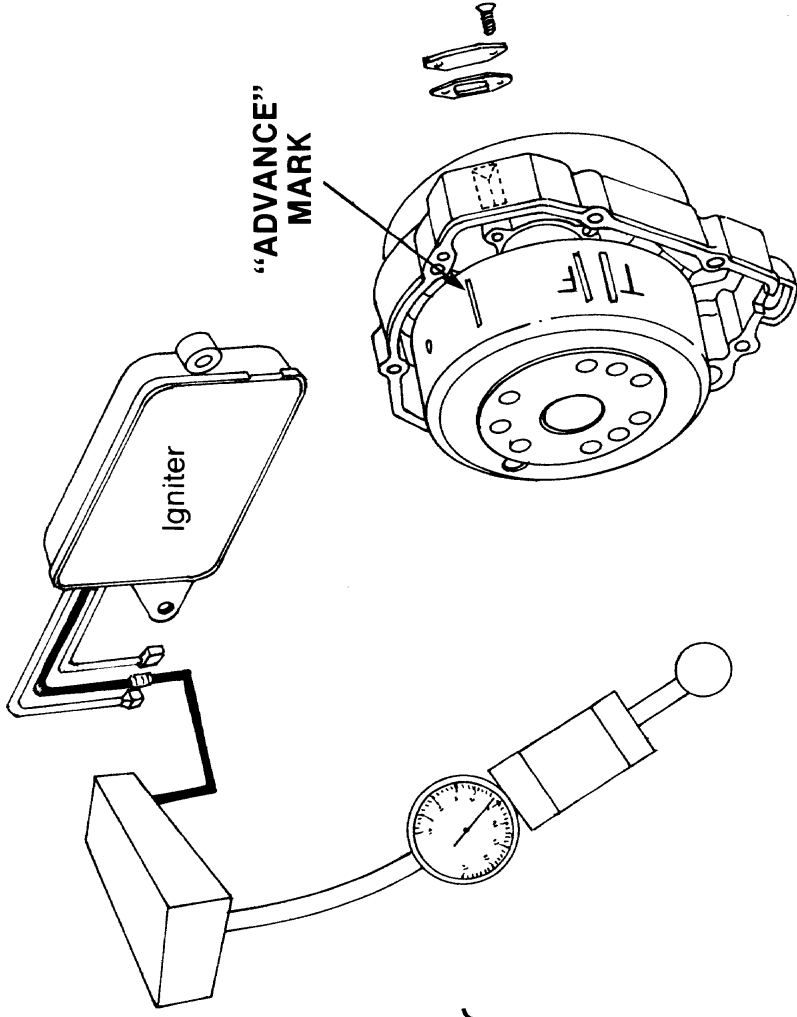

- Remove hose from vacuum sensor.
- Run engine at idle RPM.
- “F” mark on rotor should align with pointer on alternator cover.
- Increase engine speed to 2,000 RPM and “ADVANCE” mark on rotor should align with pointer on alternator cover.
- Replace Igniter if timing is not as specified.
- Return engine to idle RPM. Timing should be on “F” mark.
- Using a vacuum pump, apply 15 to 20 inches of vacuum to sensor.
- Timing should advance approximately to the “ADVANCE” mark.
- Replace vacuum sensor if timing is not as specified.

The sensor electronically detects magnetic north. Vehicle direction is determined by comparing a reference signal to the geomagnetic signal. Thus, the information sent to the control unit is the vehicle geomagnetic direction rather than its geographic direction.

The difference between geomagnetic direction and geographic direction varies, depending on where the compass is located in relation to the north and south poles. Adjustment is required to compensate for this phenomenon. The deviation adjuster has six position marks at 16° intervals, and can be turned 48° each way from center.

Interprets geomagnetic information from the sensor unit and generates an appropriate signal for the display unit to indicate correct vehicle travel by darkening the corresponding directional segment pointer.

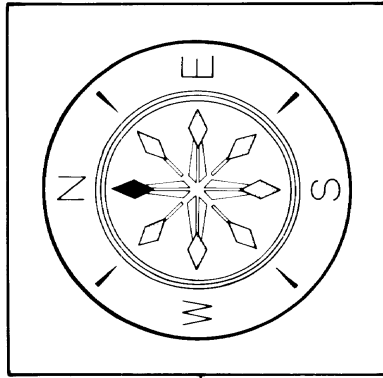

Display Unit

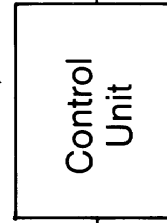

Control Unit



12 Volts When Key Switch is "ON"

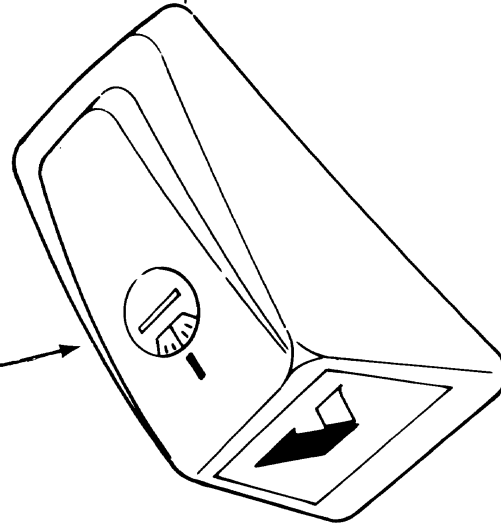

Sensor Unit

Compass System Wiring

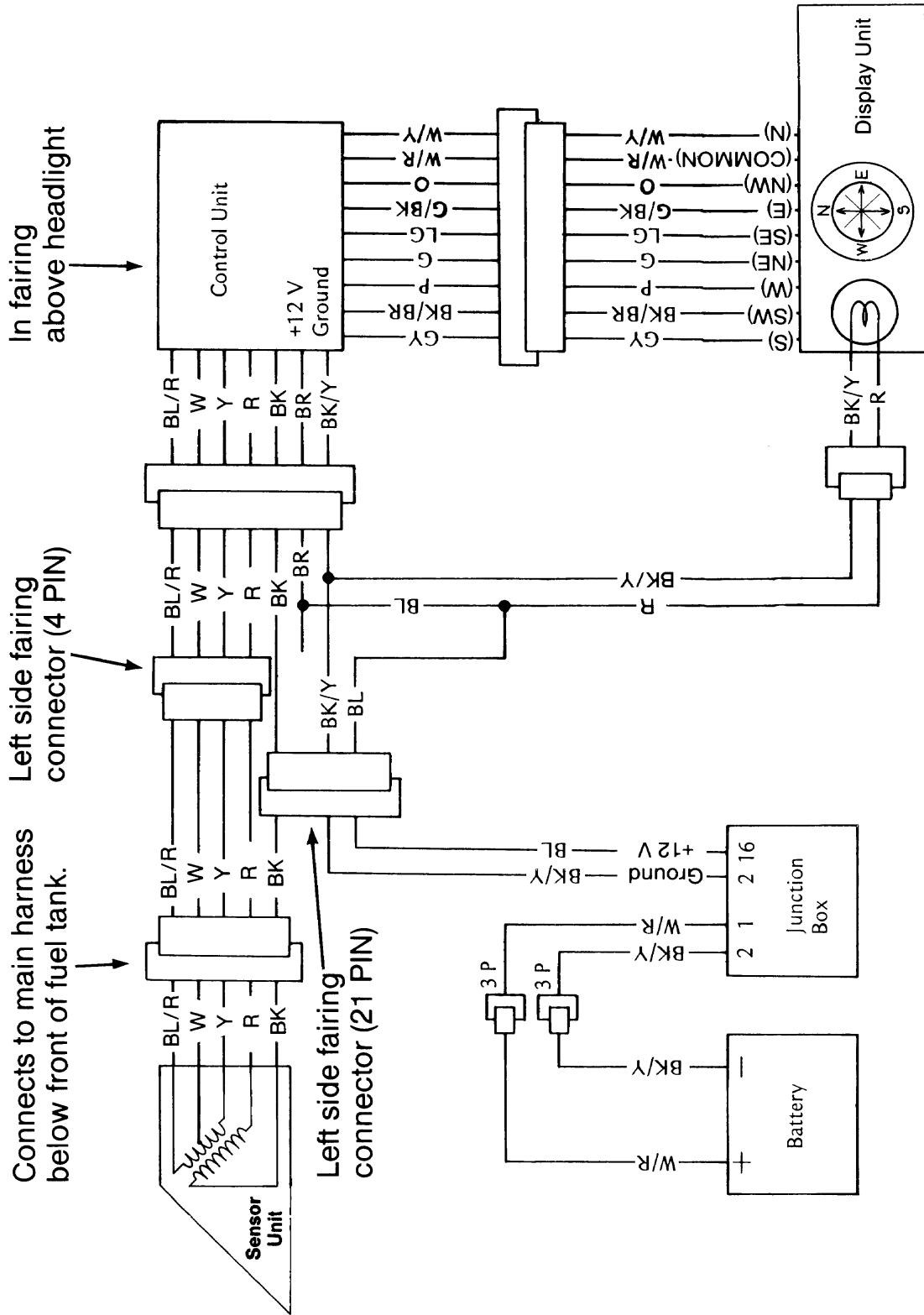

Compass System Quick Check

- Place a magnet next to sensor housing and move the magnet 360 degrees completely around the housing as indicated.
- Each compass segment should darken (one at a time) as the magnet is moved around the sensor housing. One complete revolution with the magnet should cause all segments to darken.
- If all segments do not darken, then perform the following component tests on the display unit, sensor unit and control unit.

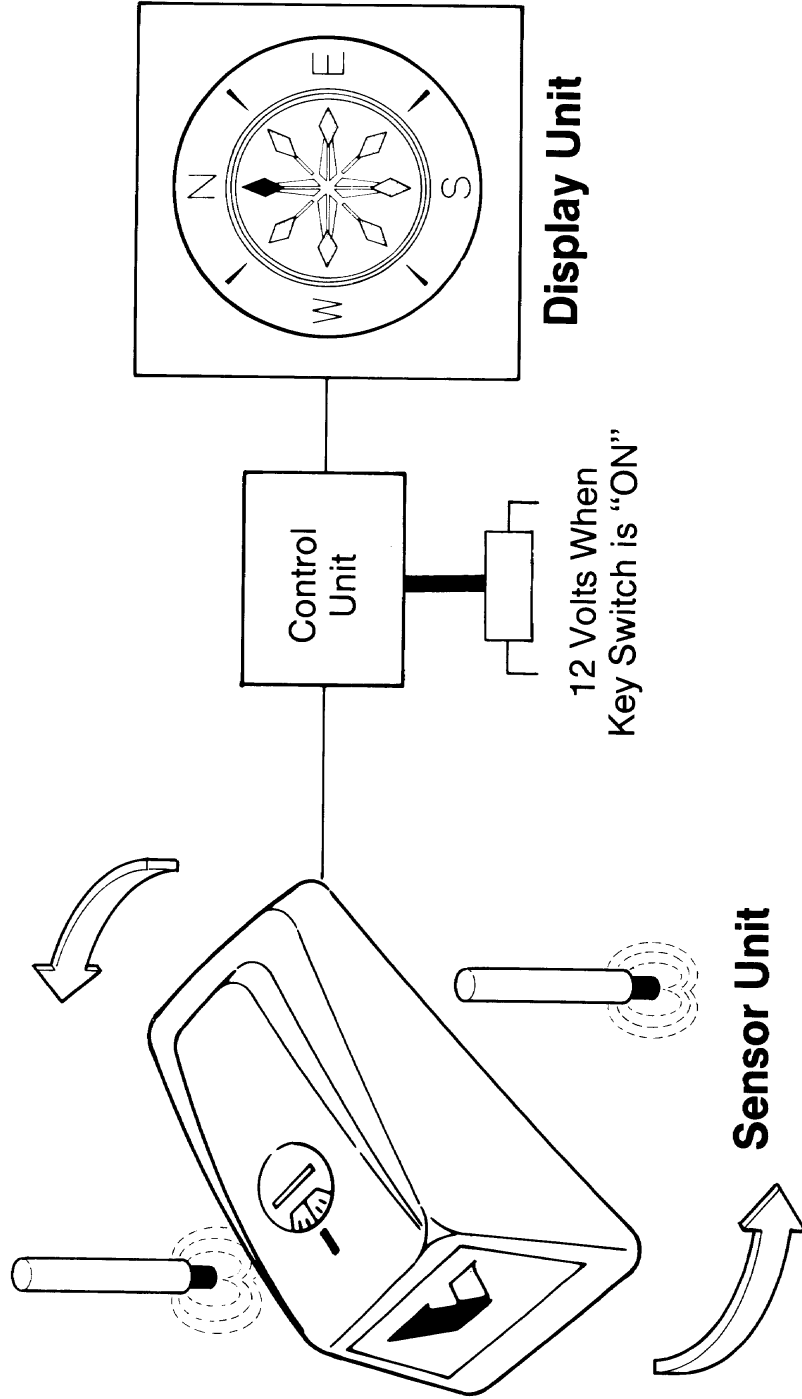

Compass Display Test

- Connect negative (-) terminal of 9 volt battery to W/R (common) wire.
- Touch positive (+) terminal of battery to remaining wires, one at a time, and the compass segments indicated in parenthesis should darken.
- Replace display if any segment will not darken with 9 volts applied.

NOTE: After removing battery voltage the segments will fade slowly.

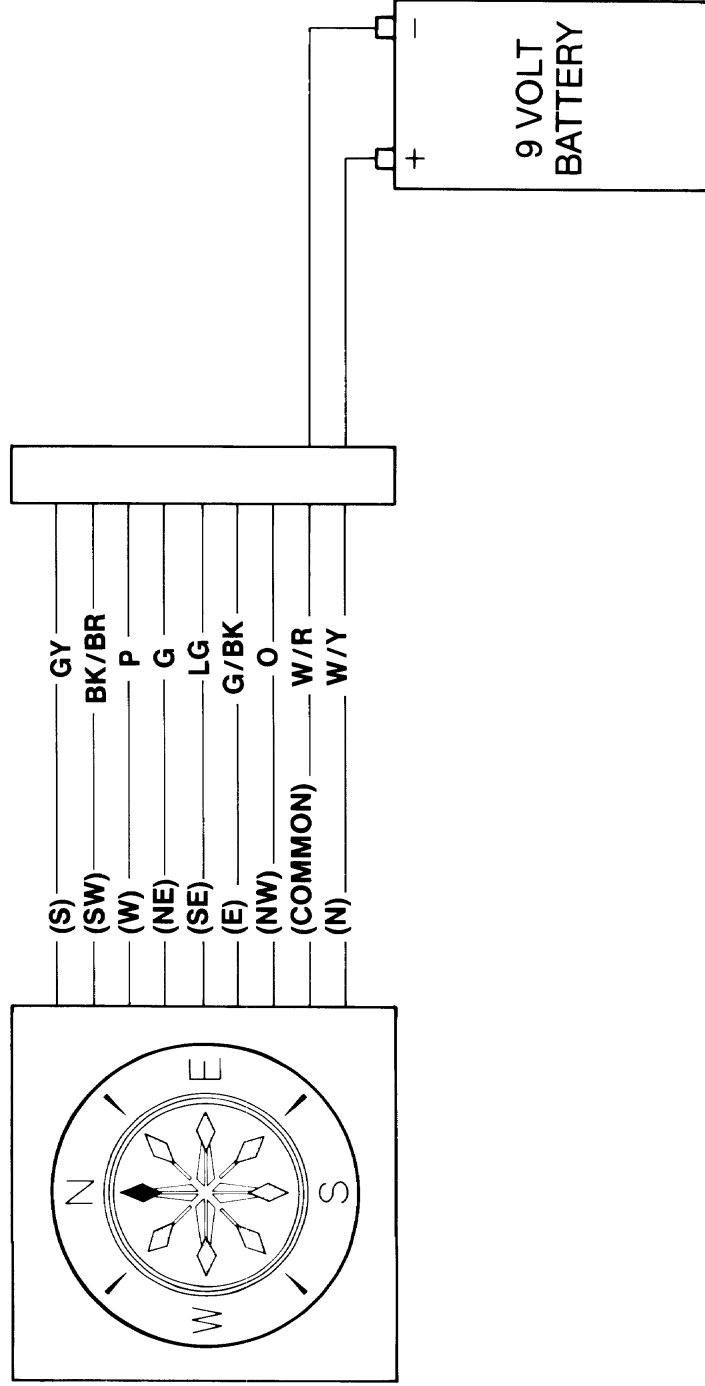

Sensor Unit Test

- Check for proper resistance between the lead wires as shown.
- Check each wire to be sure it is not shorted to ground or to the other wires.
- Replace sensor unit if resistance values are not within $\pm 5 \Omega$ of specified value.

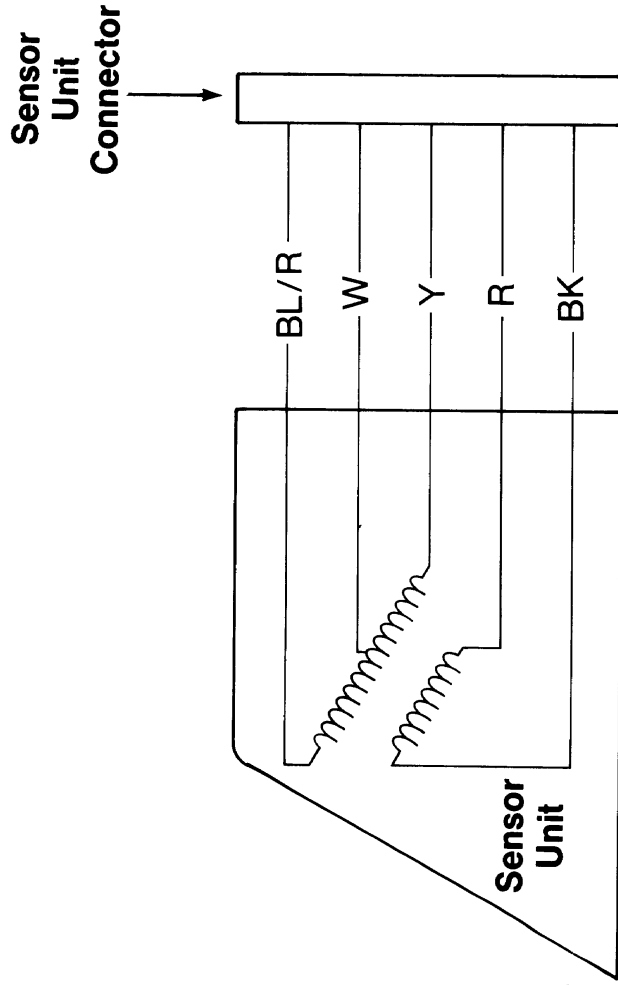
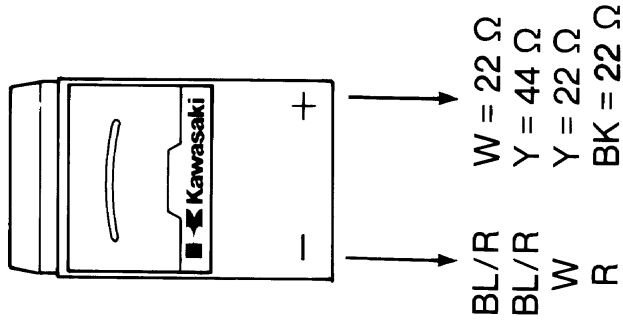

Control Unit Test

With sensor unit disconnected, display should indicate SE.

Connect jumper wire between these leads	Display Indicates
Black to Red	E
Black to Yellow	E
Black to Blue/Red	E
Black to White	N, SE

NOTE: If display indications are not as specified, replace control unit. Replace control unit if display and sensor units test good.

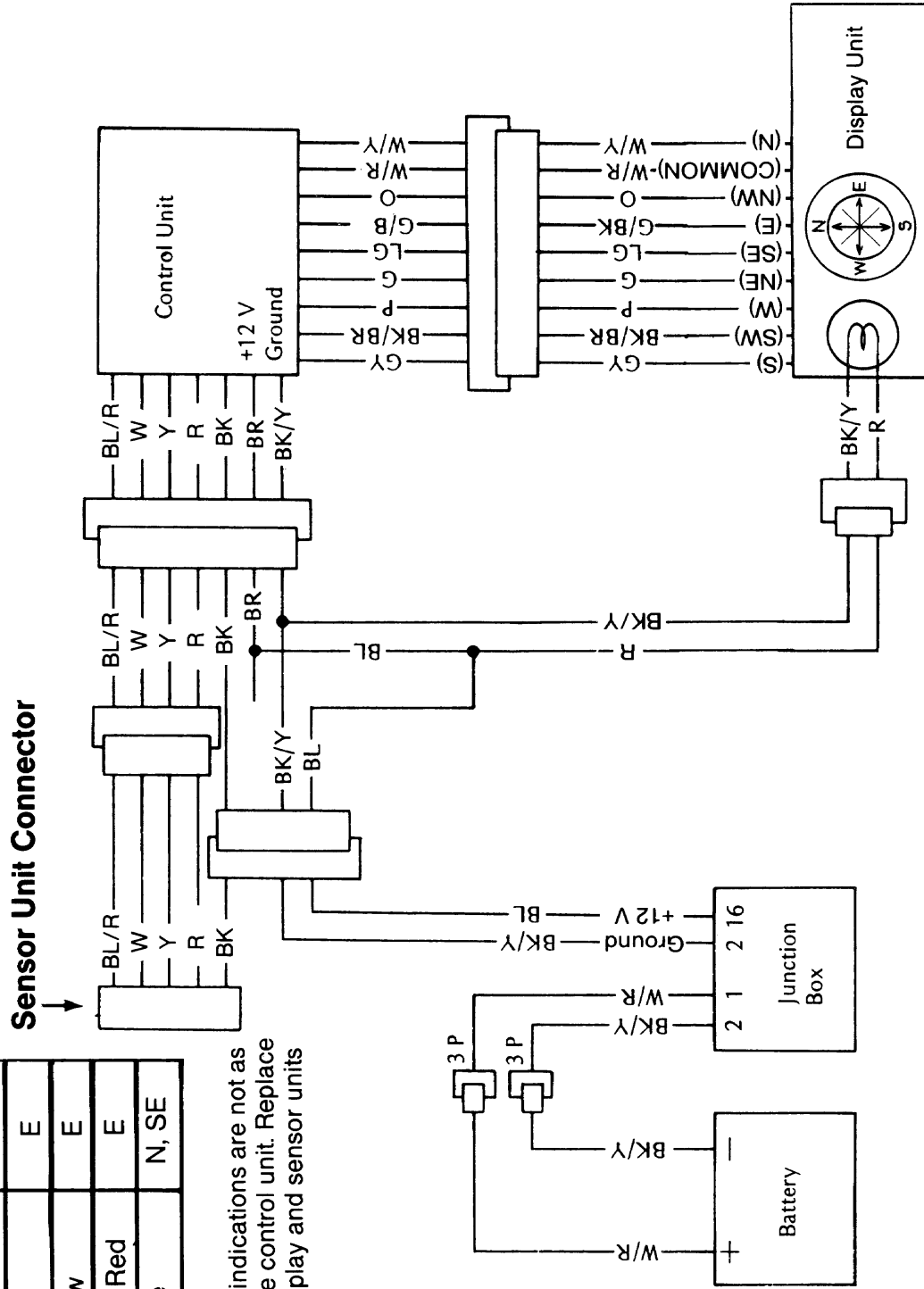

- Operator must update computer information:
 - ★ upon each engine start
 - ★ each time fuel is added
- Automatic memory clearing feature

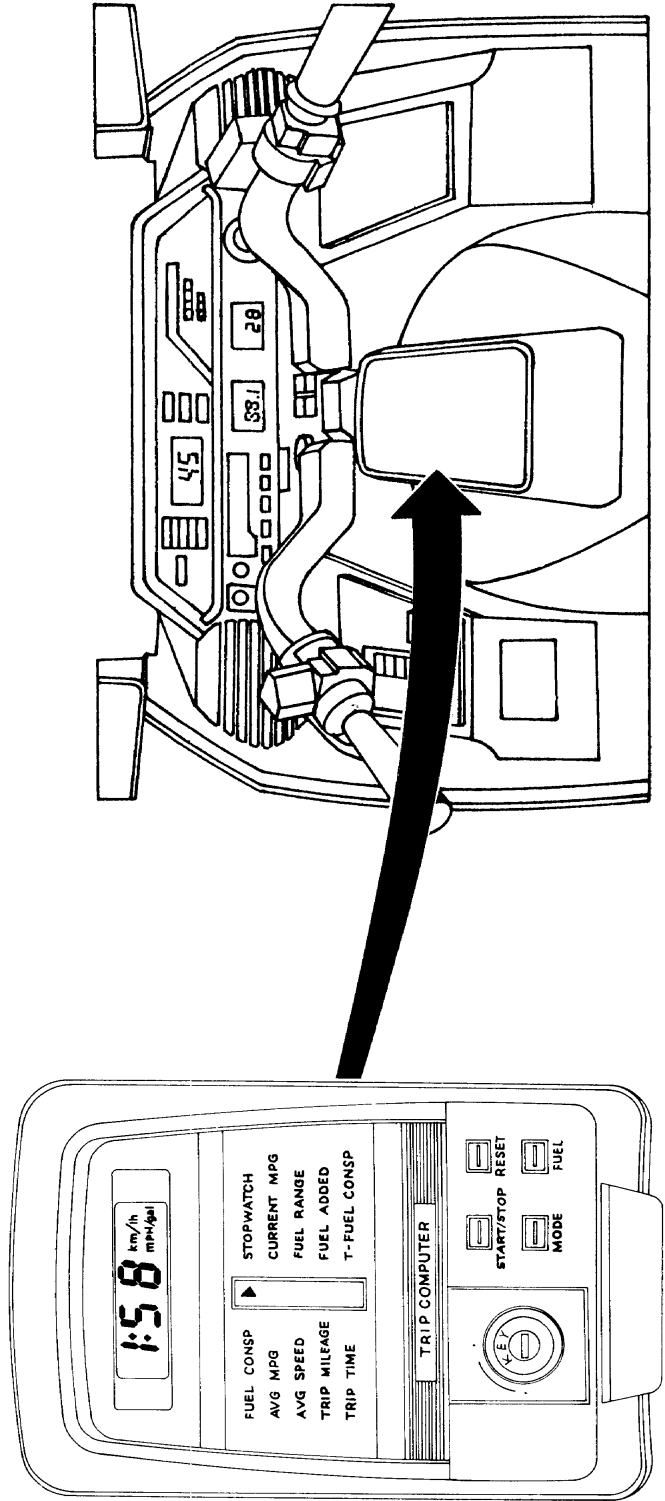

Trip Computer Modes (Functions)

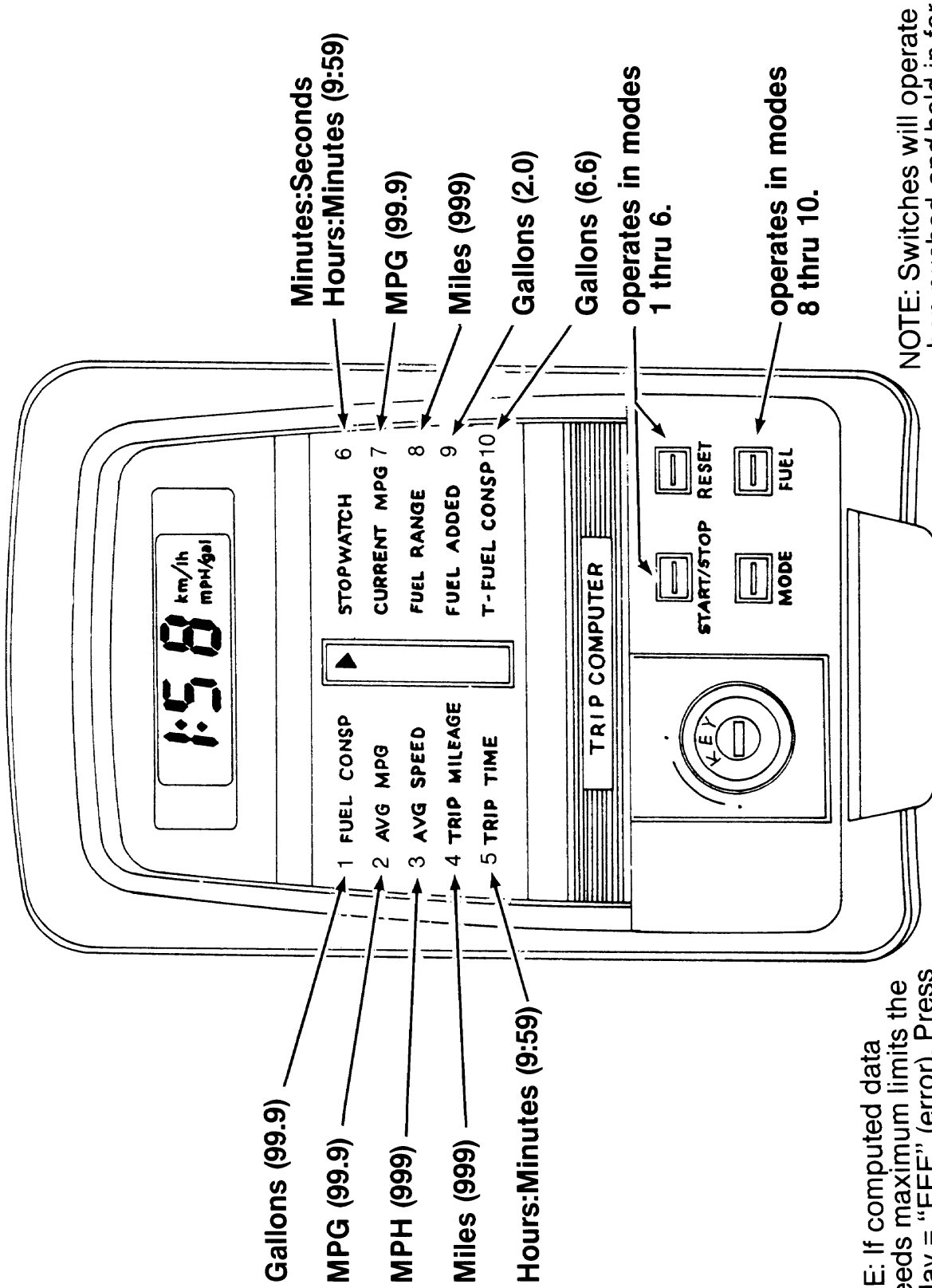

NOTE: If computed data exceeds maximum limits the display = "EEE" (error). Press RESET button to clear computer memory.

NOTE: Switches will operate when pushed and held in for more than 1/2 second.

Trip Computer Modes (Functions)

All displays are in U.S. measure only.

- FUEL CONSUMPTION**—Determines trip fuel consumption by counting the fuel injector pulse durations.
Display is in 0.1 gallon increments with 99.9 maximum.
- AVG. MPG** — Calculates average MPG of trip:

$$\text{AVG MPG} = \frac{\text{TRIP MILEAGE}}{\text{FUEL CONSP.}}$$
 Display is 0.1 gallon increments with 99.9 maximum.
- AVG SPEED** — Calculates average speed of trip:

$$\text{AVG MPH} = \frac{\text{TRIP MILEAGE}}{\text{TRIP TIME}}$$
 Display is in one MPH increments with 999 maximum.
- TRIP MILEAGE** — Counts speedometer sending unit pulses from front axle.
Display is in one mile increments with 999 maximum.
- TRIP TIME** — Determined by timer in trip computer. Does not function when key is OFF.
Display is in hours:minutes with 9:59 maximum.
- STOP WATCH** — Determined by timer in trip computer. Continues to operate when key is OFF.
Display is in minutes:seconds up to 9 minutes and 59 seconds, then becomes hours:minutes 0:10 to 9:59.
- CURRENT MPG** — Computes instantaneous MPG by calculating fuel injector pulse durations and speedometer sending unit pulses each 2.5 seconds of the trip.
Display is in 0.1 MPG increments with 99.9 maximum.
- FUEL RANGE** — Calculates approximate remaining distance that can be traveled at current rate of fuel consumption until fuel

reserve must be selected. This data is computed and updated for display with each 25 cc of fuel used.
Display is in one mile increments with 999 maximum.

9. **FUEL ADDED** — Enters quantity of fuel added to tank during “partial fill-up” into computer memory. Operator must input fuel quantity by pressing the “FUEL” button the required number of times to attain proper amount on display panel. Each time “FUEL” button is pressed, quantity will increase 0.2 of a gallon. Display is in 0.2 gallon increments with 2.0 maximum.

10. **TTL FUEL CONSP** — Displays quantity of fuel consumed from fuel tank.
Display is in 0.1 gallon increments with 6.6 maximum.

MODE BUTTON—When pressed, allows operator to select desired function and display of trip computer system.

START/STOP BUTTON—Controls stopwatch mode operation.

Button must be pressed “each time after key is turned on and prior to initial vehicle movement” if cumulative trip data is desired.

FUEL BUTTON—Enters fuel quantity added into trip computer memory and on display panel (fuel added mode). If fuel tank is “filled,” then enter fuel quantity by selecting “TTL FUEL CONSP” mode, then press “FUEL” button one time. This will reset display to zero, which is an easier process than the “FUEL ADDED” mode.

RESET BUTTON—When pressed, will clear memory information of mode selected. **NOTE:** All five modes on left side of computer will reset simultaneously.

Trip Computer Input Signals

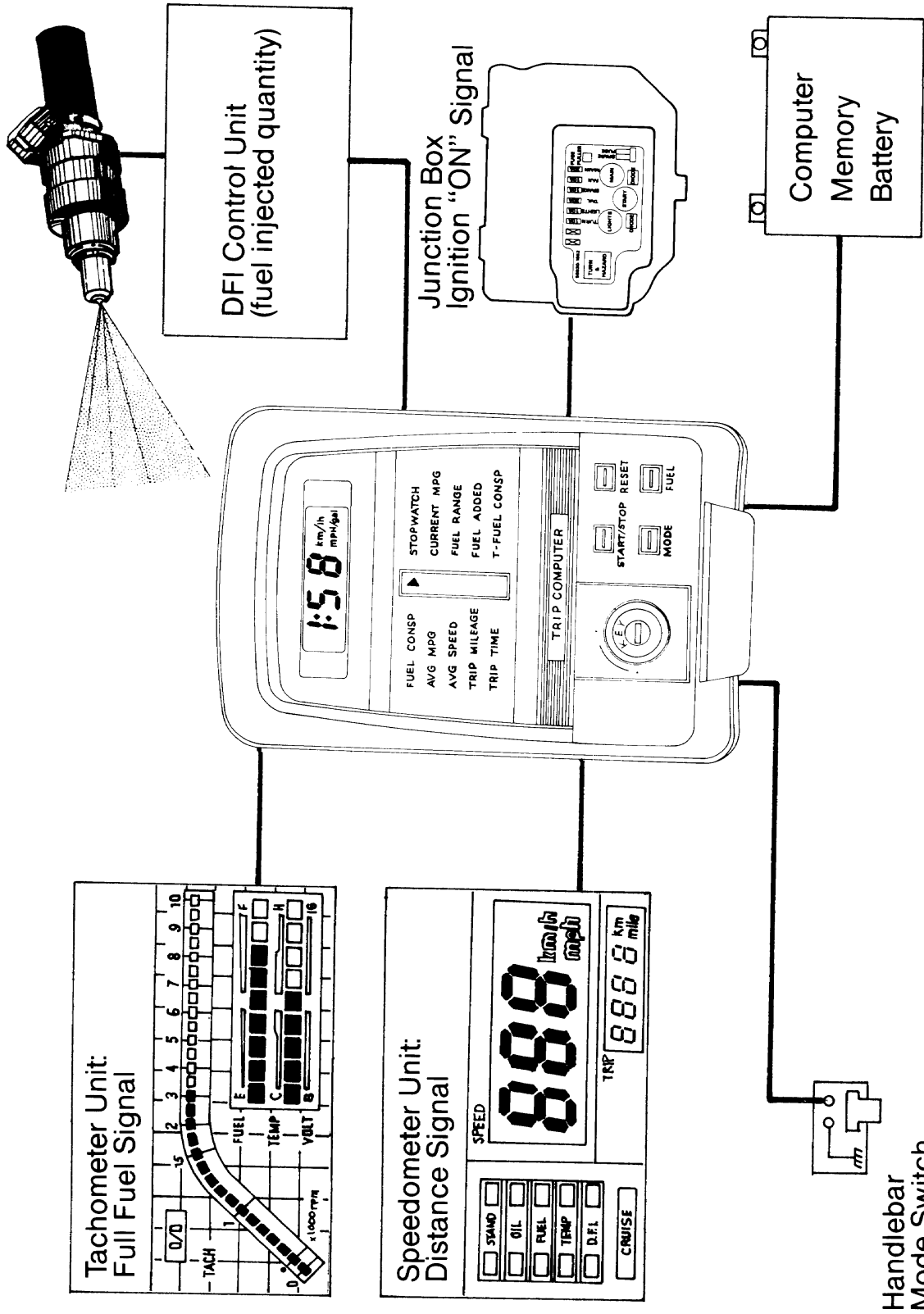

Trip Computer System

Located below fuel tank

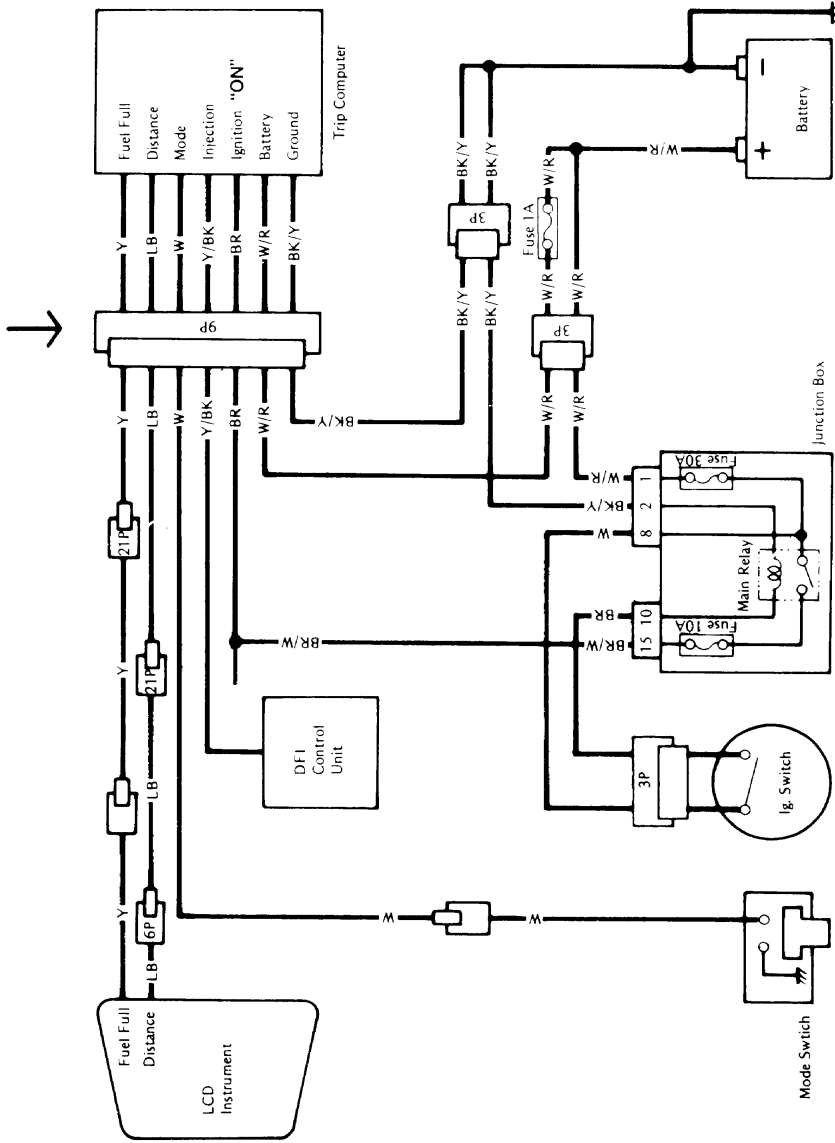

Power Supply To Trip Computer

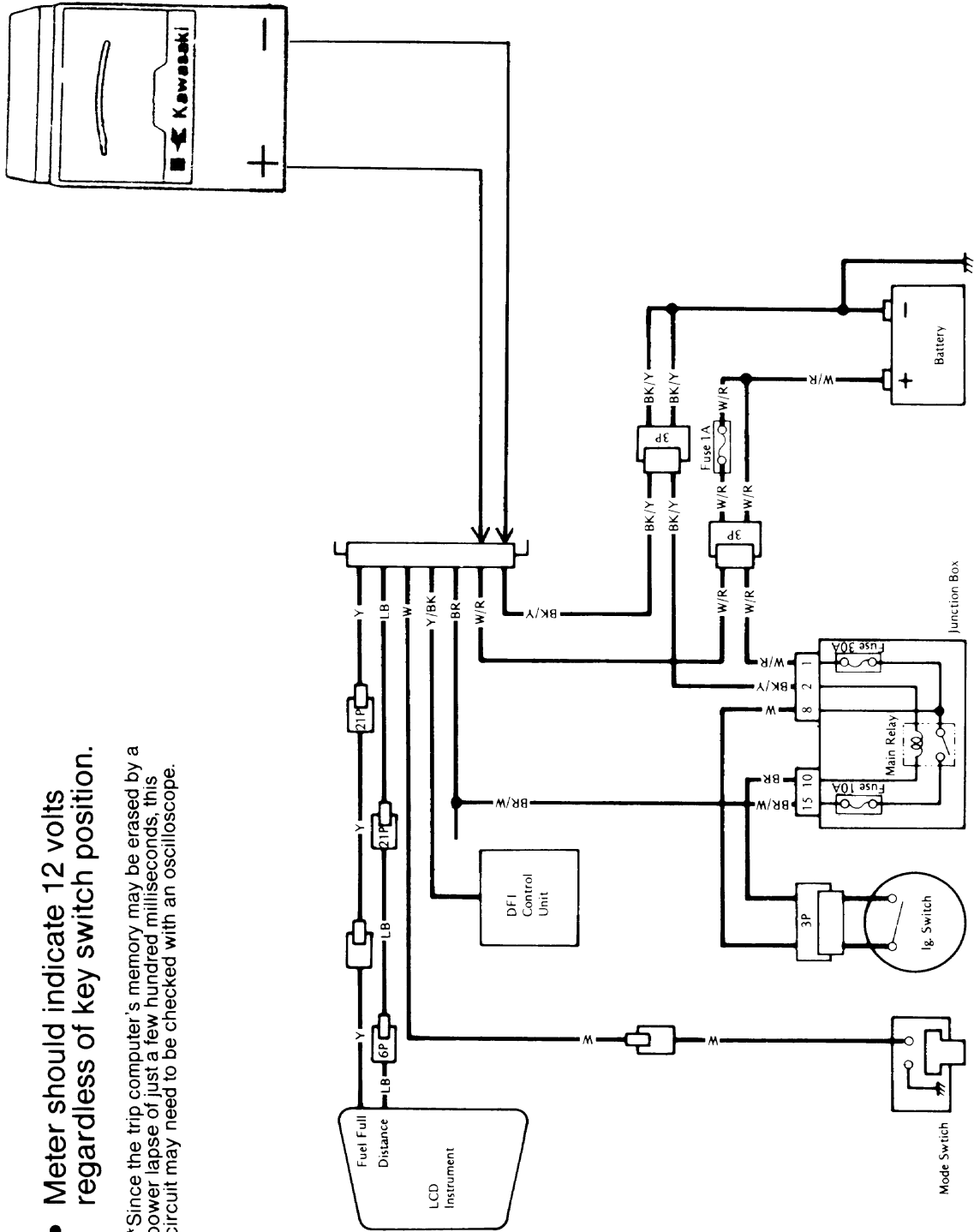

- Meter should indicate 12 volts regardless of key switch position.

*Since the trip computer's memory may be erased by a power lapse of just a few hundred milliseconds, this circuit may need to be checked with an oscilloscope.

Ignition "ON" Signal

- Turn key "on"
 - Meter should indicate 12 volts
- * Since the trip computer's memory may be erased by a power lapse of just a few hundred milliseconds, this circuit may need to be checked with an oscilloscope.

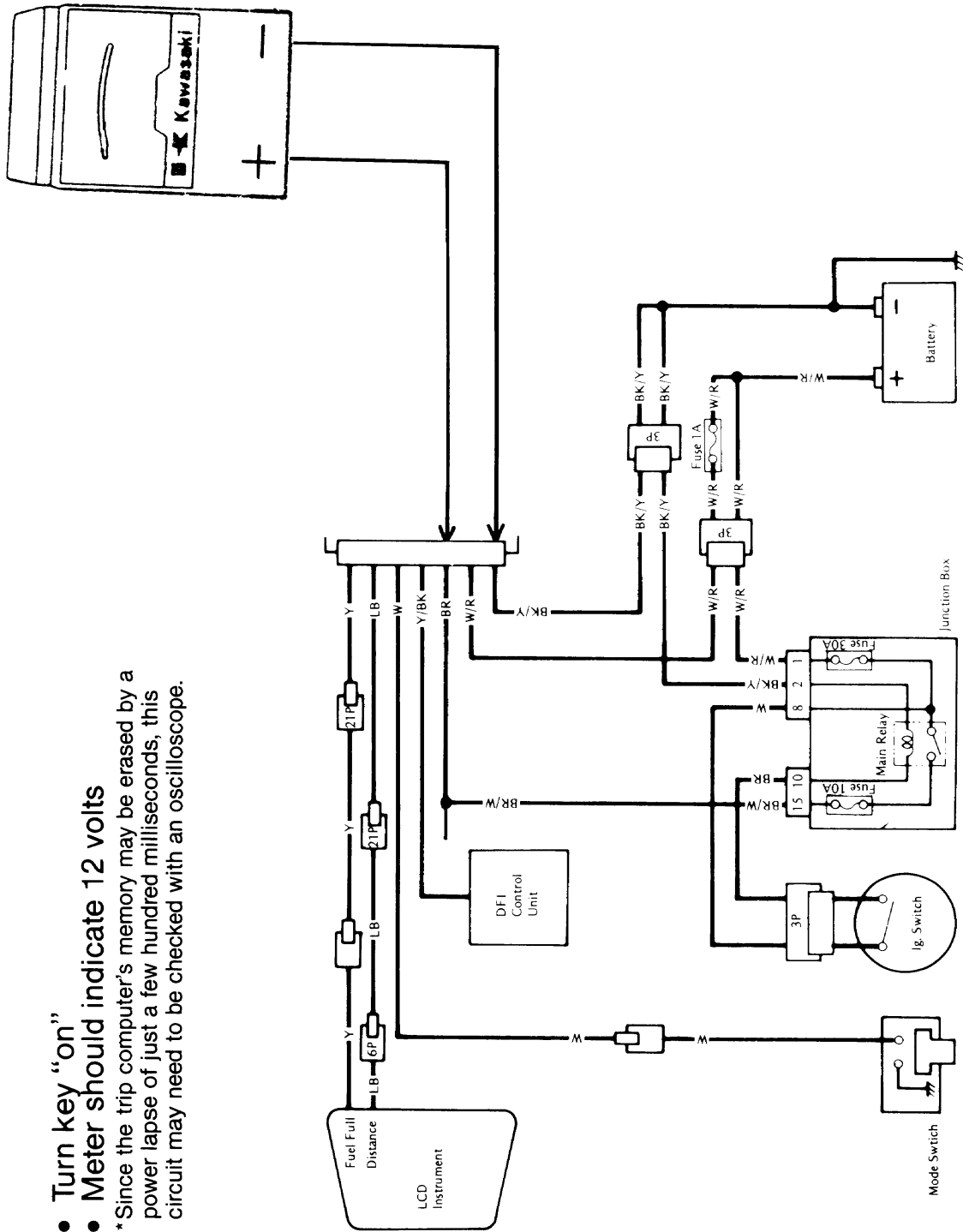

Fuel Injected Quantity

- Measure voltage with trip computer connected.
- With engine running, meter should indicate more than 3 volts.
- Slight fluctuation (approx. 0.5 volt) is normal.
- Replace DFI Control Unit if signal is not as specified.

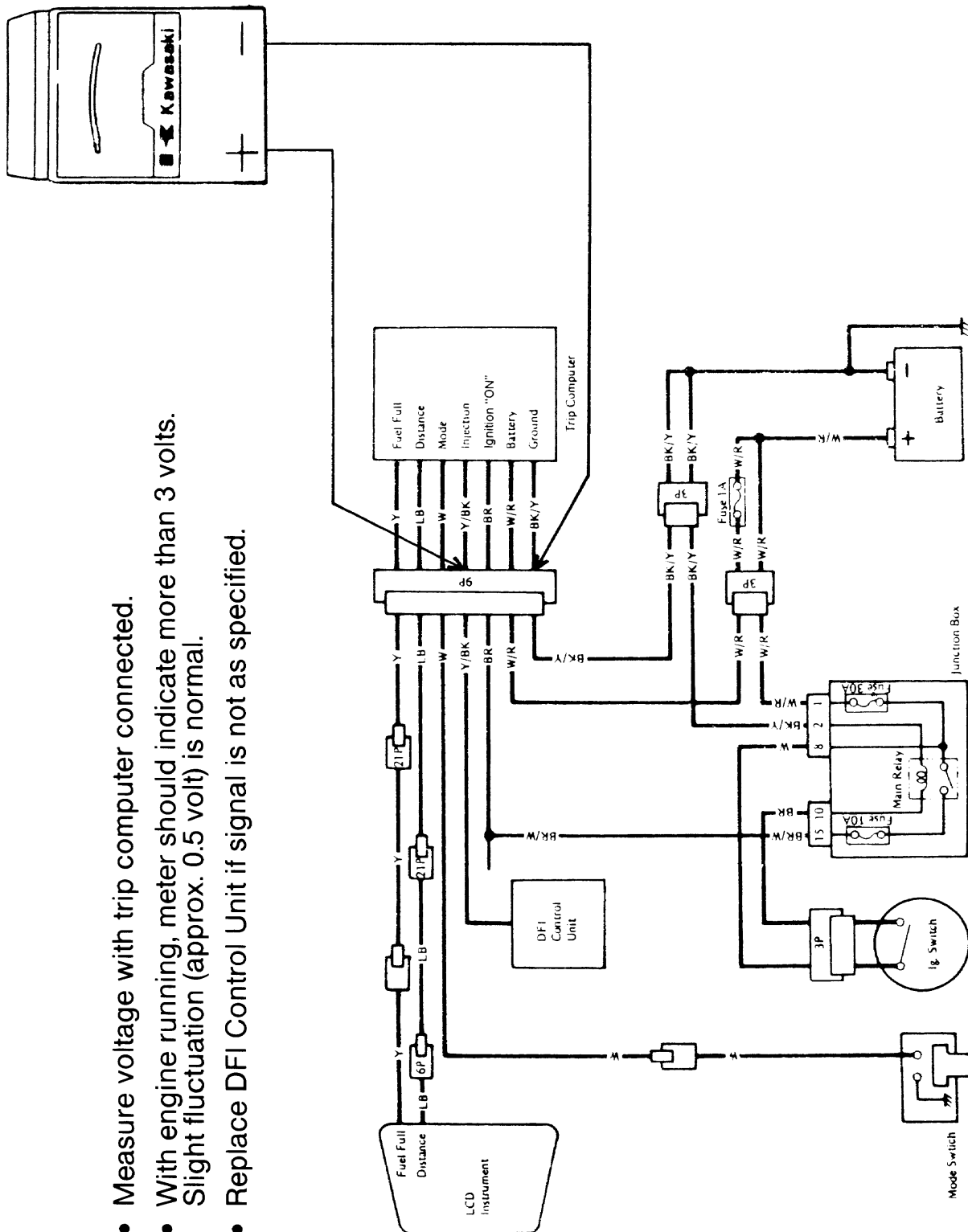

Distance Signal To Trip Computer

- Measure voltage with trip computer connected.
- Rotate front wheel and meter should indicate 23 pulses per revolution of 4.0 to 6.0 volts and then less than 0.2 volts.
- Refer to instrument system wiring if signal is not as specified.

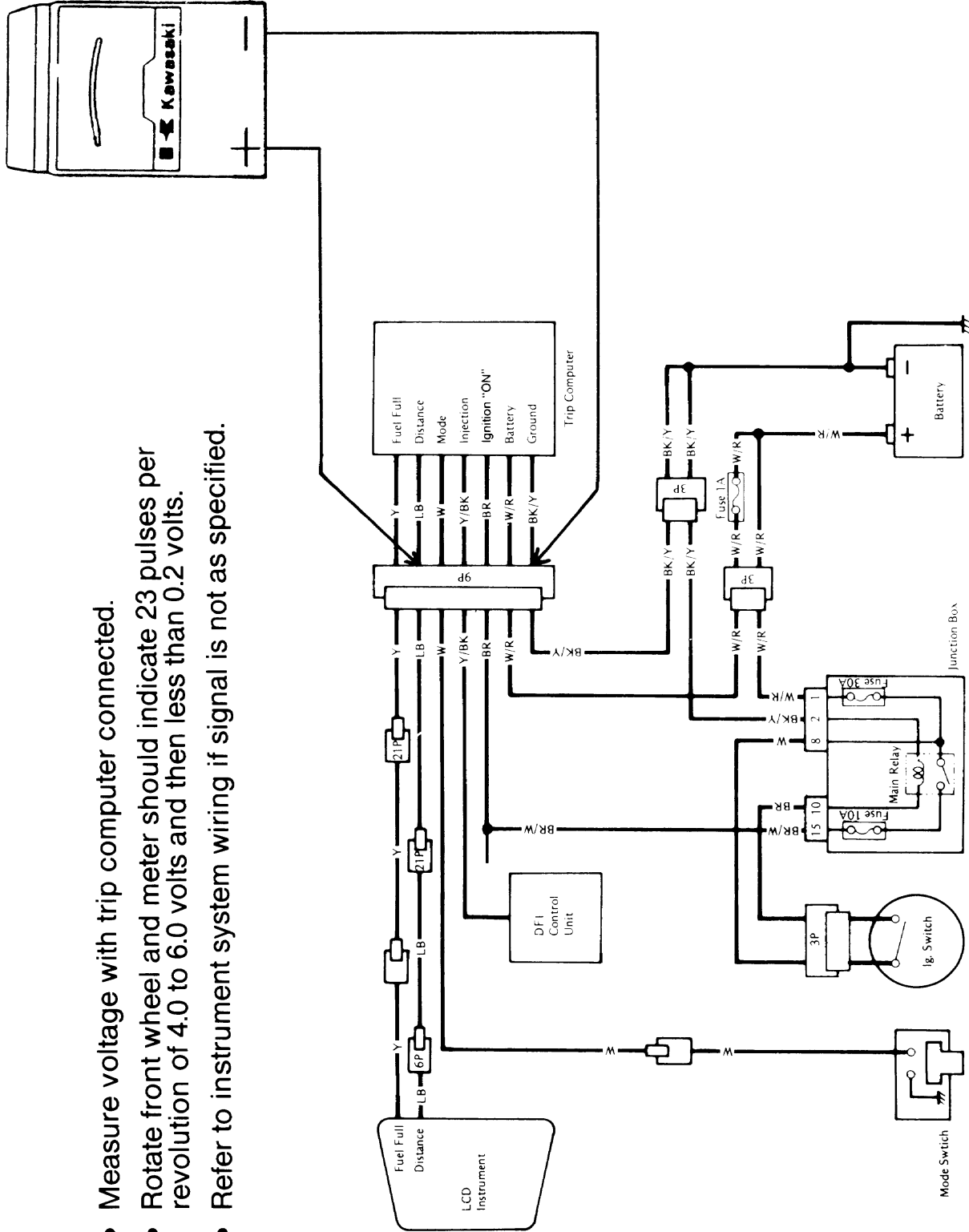

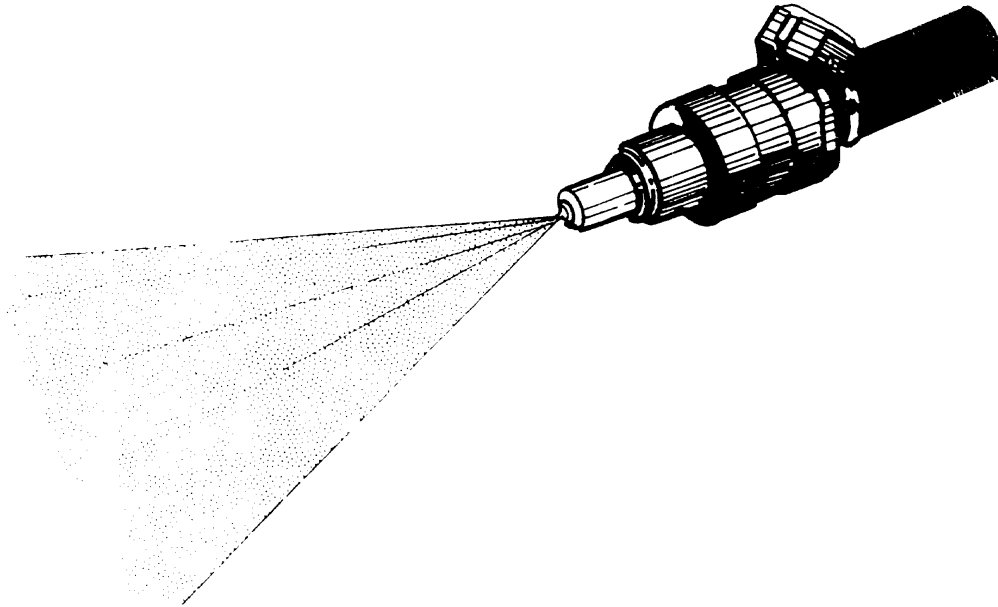

System Features:

- Precise fuel delivery under varying operating conditions.
- Fail-safe design.
- Self-diagnosis capability.
- Fuel cut over-rev limiter system.
- Delivers performance or economy (cruise switch).

DFI Fail-Safe and Self-Diagnosis Feature

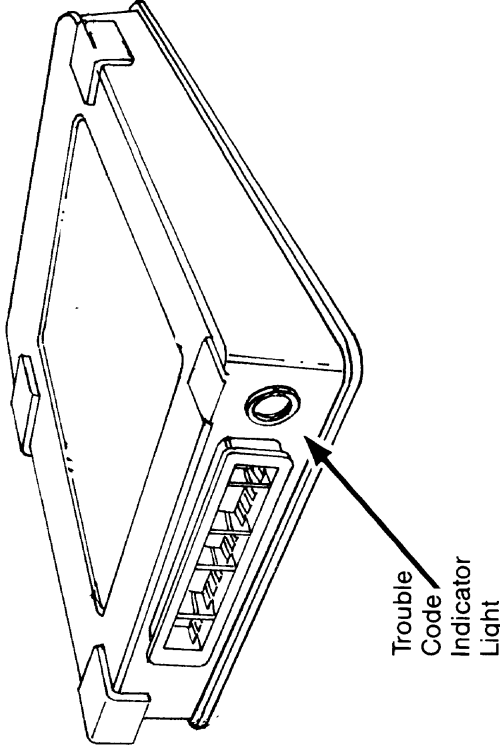

Fail-Safe Operation:

- The DFI control unit analyzes the DFI system while the engine is running. If trouble occurs in the DFI system while riding, the DFI control unit takes the following measures:
- It turns on the fail-safe system. By ignoring abnormal signals which are sent from damaged sensor(s) or through damaged wires and by using the fail-safe data in computer memory, the DFI control unit computes the fuel amount to be injected. Fail-safe data is chosen to minimize the influence of system damage.
 - It sends a signal to the DFI warning indicator to notify the rider of the DFI system trouble.

Self-Diagnosis Operation:

Until the ignition switch is turned off, the DFI control unit keeps the faults in its memory and continues to turn the green LED (Light Emitting Diode) on and off repeatedly to notify the mechanics of faults. This greatly helps them to troubleshoot the DFI system. Pulses of green light can be seen through the inspection hole in the control unit. Arrangement of long and short pulses express the trouble codes which correspond to the faults.

“NOTE”

The DFI control unit keeps system troubles in its memory, even if they occur while the ignition switch is on. However, the control unit resets and clears memory when the ignition switch is turned off.

Self-Diagnosis and Trouble Code

Items	Criteria	Trouble Codes	Arrangement of Pulses*	Action
Throttle Sensor	Open or Short	11	<input type="checkbox"/>	Perform "Throttle Angle Signal Test". Opening
Air Temperature Sensor	Open or Short	12	<input type="checkbox"/> <input type="checkbox"/>	Perform "Air Temperature Signal Test".
Engine Temperature Sensor	Open or Short	13	<input type="checkbox"/> <input type="checkbox"/> <input type="checkbox"/>	Perform "Engine Temperature Signal Test".
Atmospheric Pressure Sensor	Open or Short	21	<input type="checkbox"/> <input type="checkbox"/> <input type="checkbox"/>	Replace control unit.
Starter Switch	Continues on after engine starts.	22	<input type="checkbox"/> <input type="checkbox"/> <input type="checkbox"/>	Perform "Starter Signal Test" and inspect starter switch for damage.
Ignition Pulse	No ignition pulses are transmitted to control unit when cranking engine.	23	<input type="checkbox"/> <input type="checkbox"/> <input type="checkbox"/> <input type="checkbox"/>	Perform "Engine Speed Signal Test", and inspect ignition system damage.
CPU** Memory	Memories in CPU do not operate properly.	31	<input type="checkbox"/> <input type="checkbox"/> <input type="checkbox"/> <input type="checkbox"/>	Replace control unit.

* : Long pulse, Short pulse

** : Central Processing Unit

Cruise Switch Operation

CRUISE SYSTEM "ON"

- Cruise display ON
- G/Y and Y/G wires not connected to ground
- Meter should indicate approximately 7.0 VDC

CRUISE SYSTEM "OFF"

- Cruise display OFF
- G/Y and Y/G wires connected to ground
- Meter should indicate 0 VDC

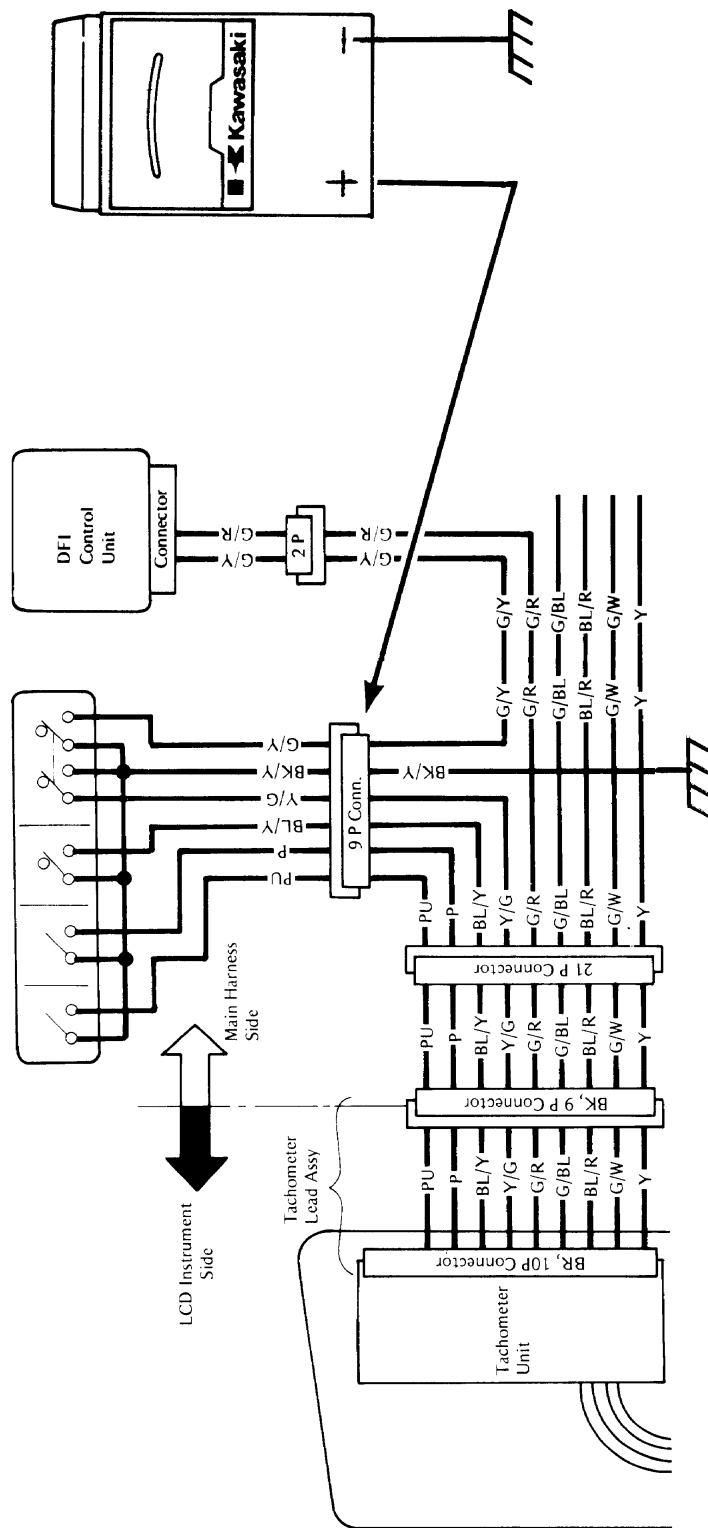

DFI Fuel System

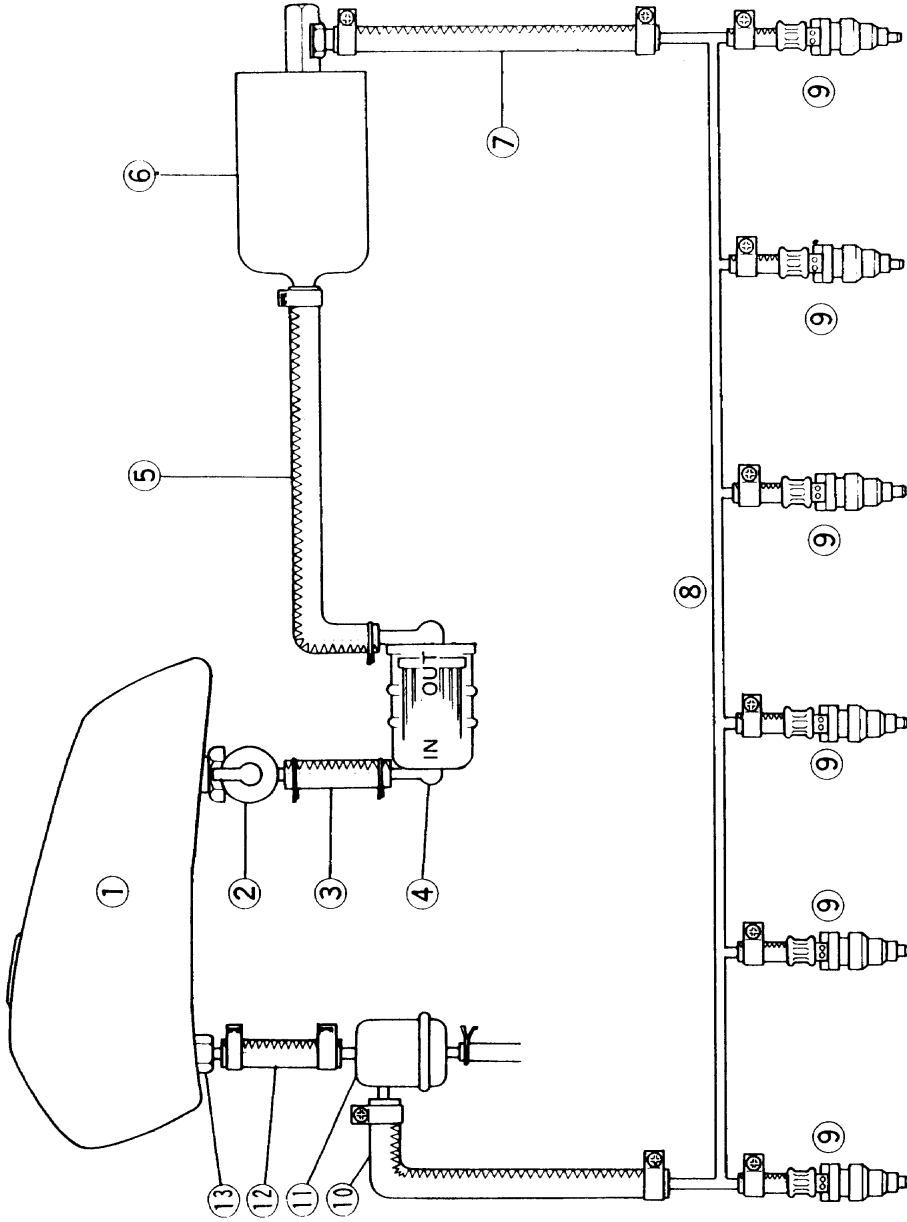

- 1. Fuel Tank
- 2. Fuel Tap
- 3. Fuel Hose (low pressure)
- 4. Fuel Filter
- 5. Fuel Hose (low pressure)
- 6. Fuel Pump
- 7. Fuel Hose (high pressure)
- 8. Fuel Distributing Pipe
- 9. Fuel Injectors
- 10. Fuel Hose (high pressure)
- 11. Pressure Regulator
- 12. Fuel Hose (low pressure)
- 13. Check Valve

Canister and Separator Operation

Canister

The canister is designed to work well throughout the motorcycle's life without any maintenance, if it is used under normal conditions.

CAUTION

If gasoline, solvent, water or any other liquid enters the canister, the canister's vapor absorbing capacity is greatly reduced and there is no way to return it to the original level. In that case, replace the canister with a new one.

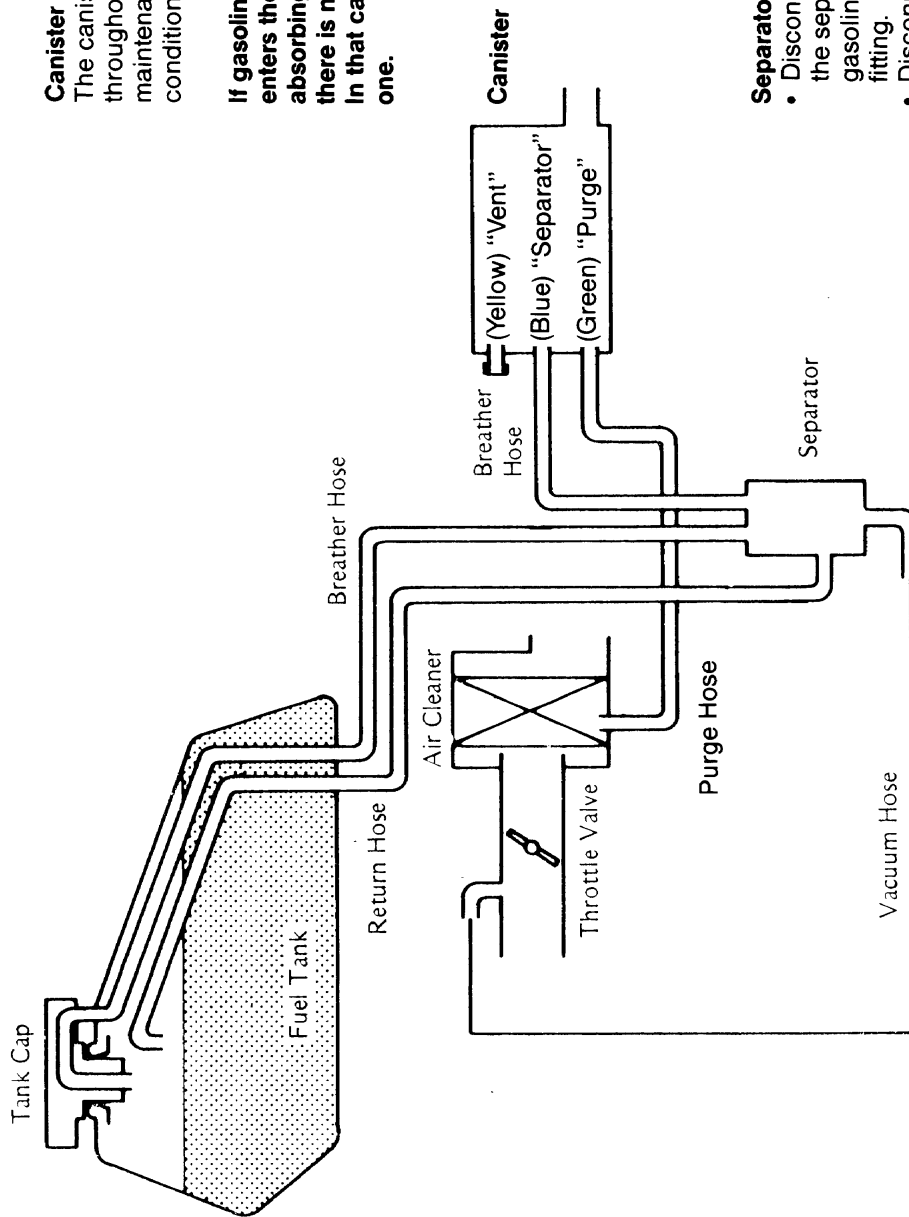

Separator Test

- Disconnect one of the breather hoses from the separator, and inject about 20mL of gasoline into the separator through the hose fitting.
- Disconnect the fuel return hose from the fuel tank.
- Run the open end of the return hose into a container level with the fuel tank top.
- Start the engine, and let it idle.
- ★ If the gasoline in the separator comes out of the hose, the separator works well. If it does not, replace the separator with a new one.

Liquid Crystal Display (LCD) Instruments and Indicators

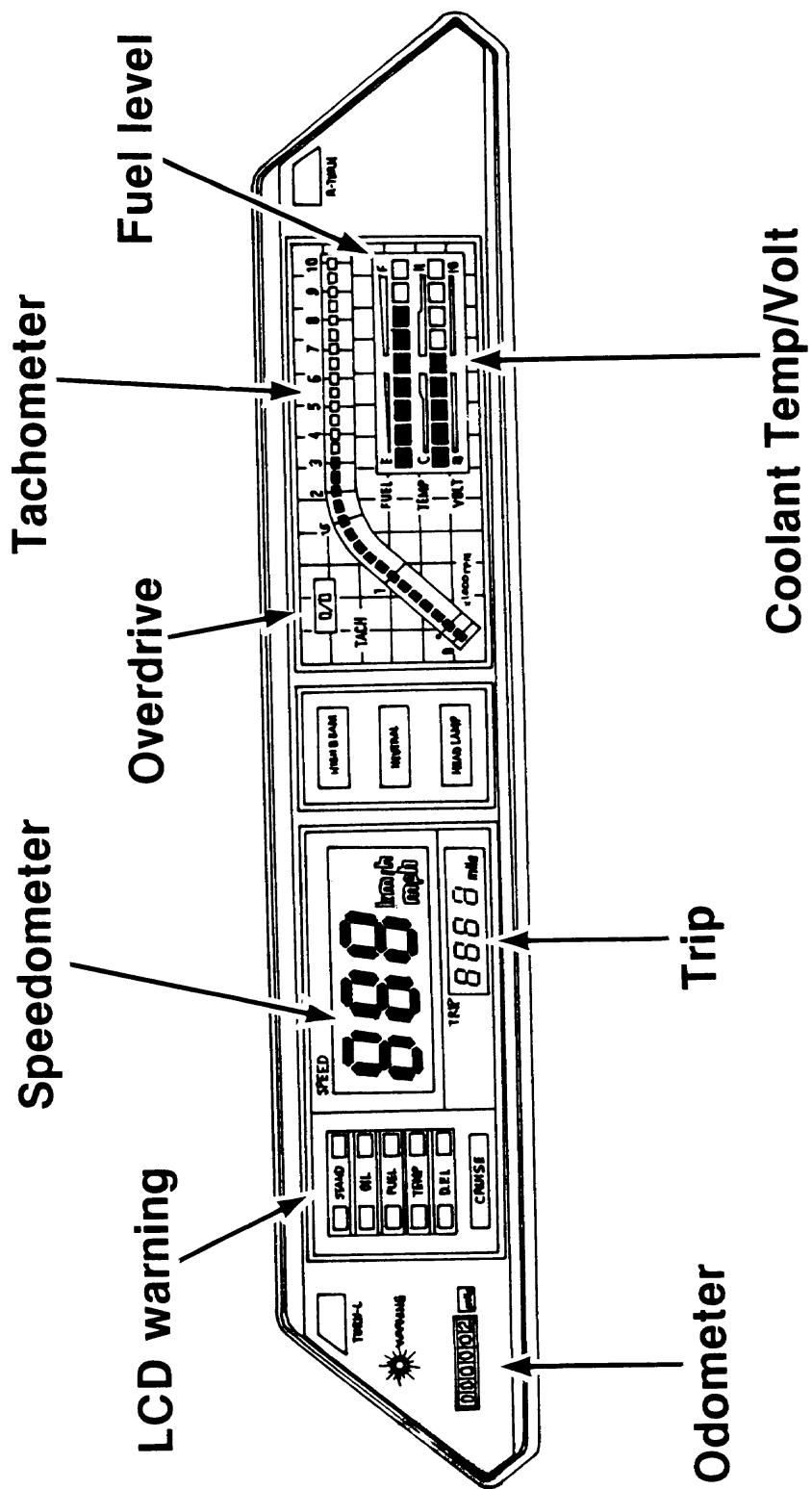

LCD Construction

The liquid crystal display panel is an optically transparent “sandwich” that has many components that don’t meet the eye at first glance. Two glass panels make up the front and back of the device. The inner surfaces have a thin-film metallized coating. On the front-plane, the film has been deposited to produce the seven-segment patterns of numerals and the thin-film connectors that lead to a “connector” edge. Thus each film metallized segment is individually addressable. The back-plane is metallized over its entire inner surface.

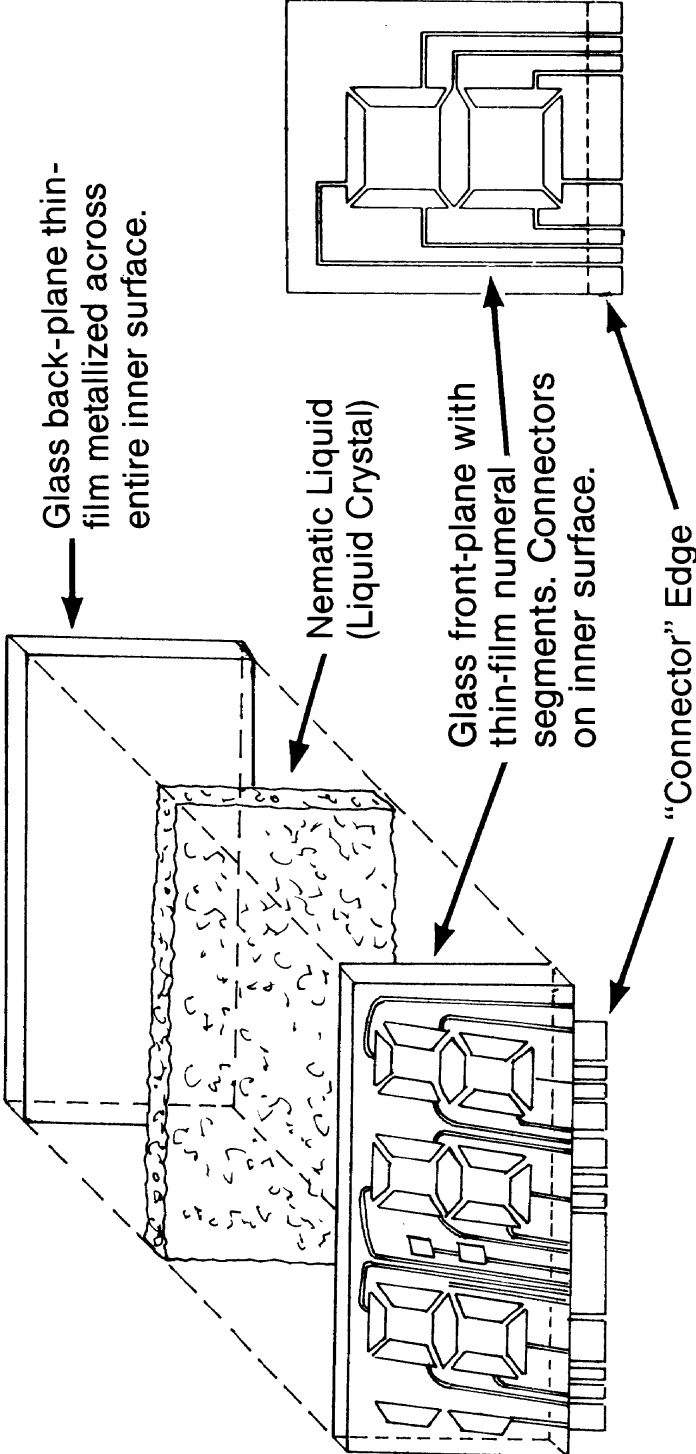

LCD Power "Off"

The two metallized glass panels don't touch. They are separated by a one-mil thick teflon spacer and a normally transparent fluid called a nematic liquid. The liquid crystals are suspended in the nematic liquid. Normally these cigar-shaped molecules are in parallel alignment. In this state, the crystal molecules don't reflect or scatter light and the liquid appears transparent.

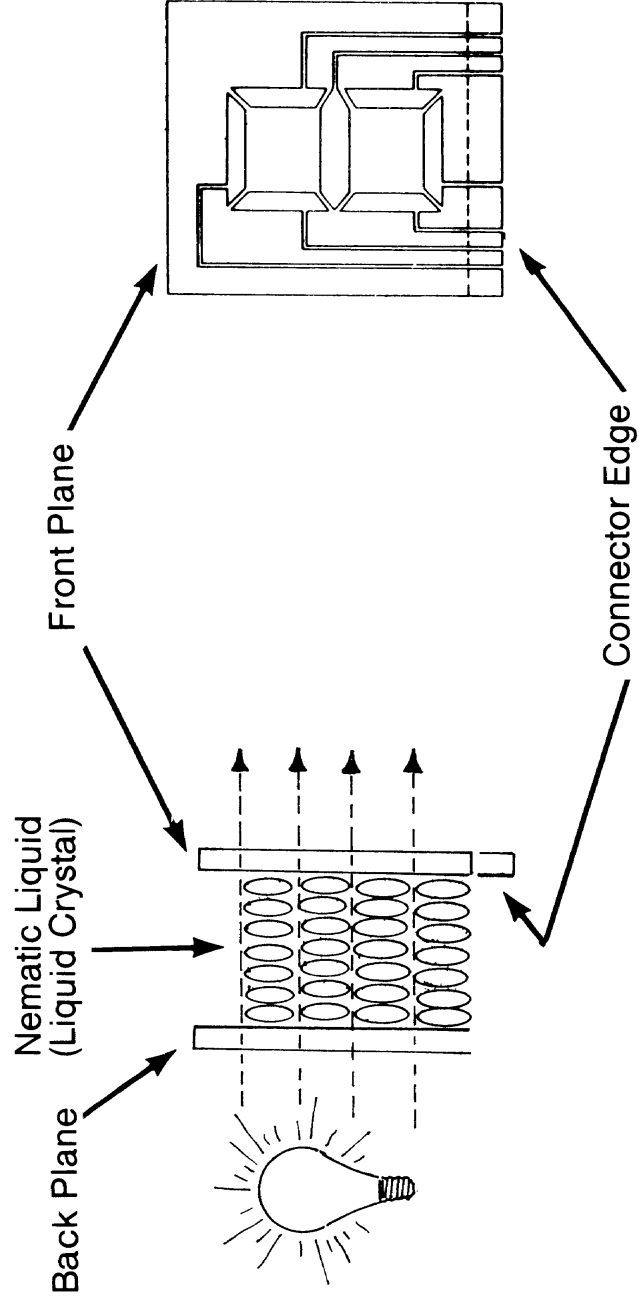

LCD Power “On”

However, when disturbed by an electric field, the well ordered structure is upset. The molecules organize randomly, thus scattering light passing through the LCD sandwich. This makes the affected segments in the transparent display become visible by reflecting available light. Since a LCD does not emit *any* light, they consume very little electrical energy (usually about 4 to 5 micro-amps per segment). They do need indirect lighting to make the display appear clear and visible when the ambient light is low.

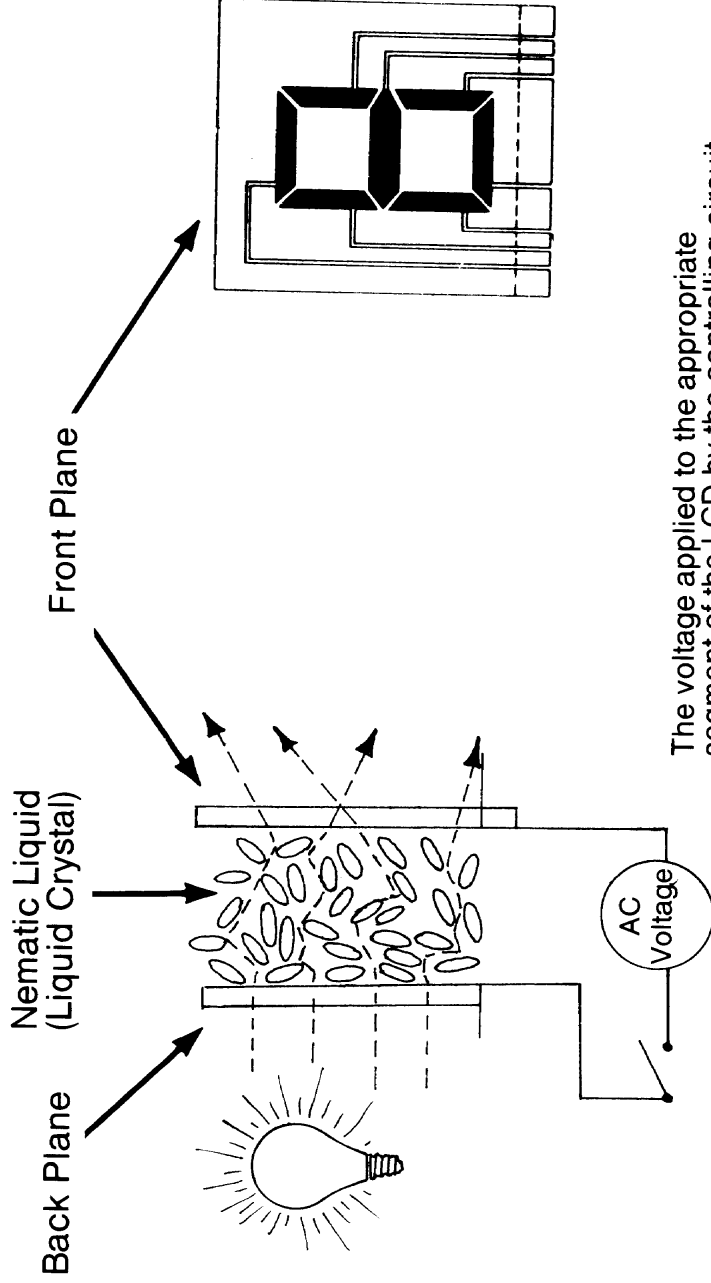

The voltage applied to the appropriate segment of the LCD by the controlling circuit must be AC or an everchanging voltage simulating an AC source. The life of a LCD (normally 5 to 8 years) is appreciably reduced if it constantly operated from a DC source.

L.C.D. Colors

A colored LCD may be obtained by tinting the back-plane, the front-plane, the indirect lighting, or using filters on the front-plane. Below 35° F, it is normal for a LCD to appear slow and lazy when changing the numeral segments. In extreme heat, above 100 degrees, the entire display might turn black. This condition is normal and will not cause damage.

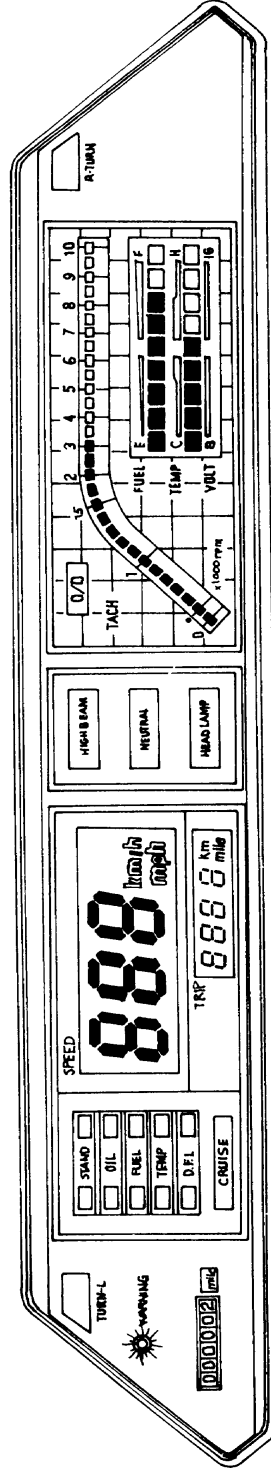

Speedometer and Tachometer Interface

Since the speedometer and tachometer units contain sophisticated circuits, they cannot be tested with conventional equipment or procedures.

Micro Computer

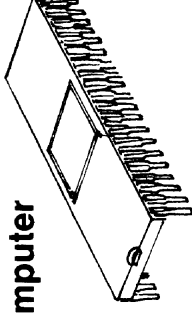

Integrated Circuits

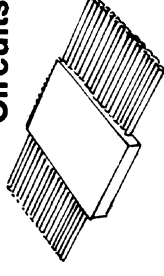

A micro computer (central processing unit) that controls the operation of all LCD circuits is located in the Tachometer Unit. Input signals are collected by both instrument units and sent to the micro computer for analysis with programs in its memory. The micro computer then sends the correct digital data to the appropriate speedometer or tachometer LCD indicator circuits.

If problems occur:

- Check the power supply voltage at speedometer unit.
- Check signal source and circuit wiring of malfunctioning indicator.
- Replace both the speedometer and tachometer units (Note: The tachometer is more likely to cause a malfunction since it contains the micro computer).

Speedometer and Tachometer Interface Circuits

- Follow engine oil level signal from switch, through tachometer, to LCD oil warning indicator in speedometer.
- Trace fuel level sensor signal through speedometer, to LCD fuel level gauge in tachometer and to the trip computer.

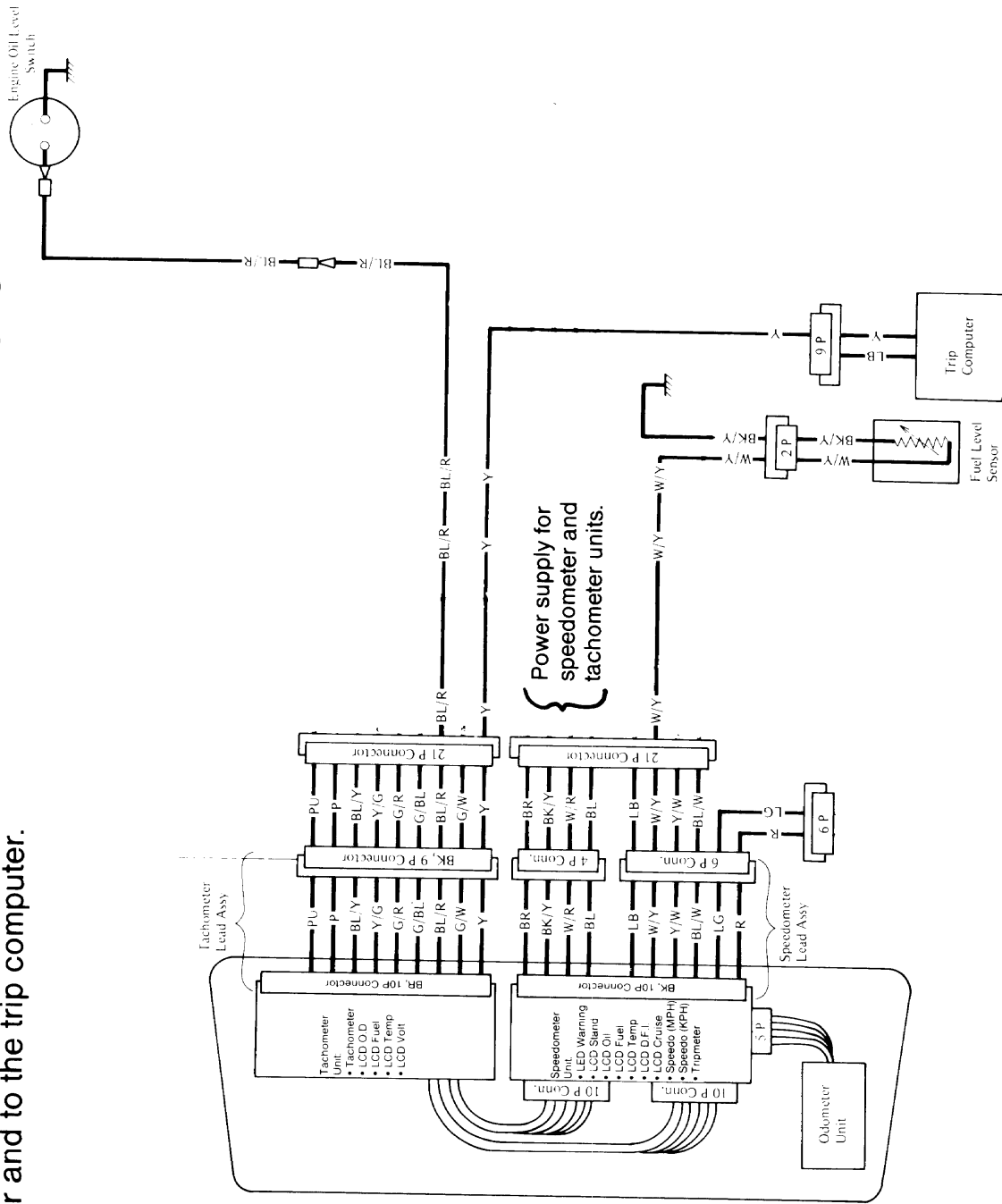

Instrument Signal Review

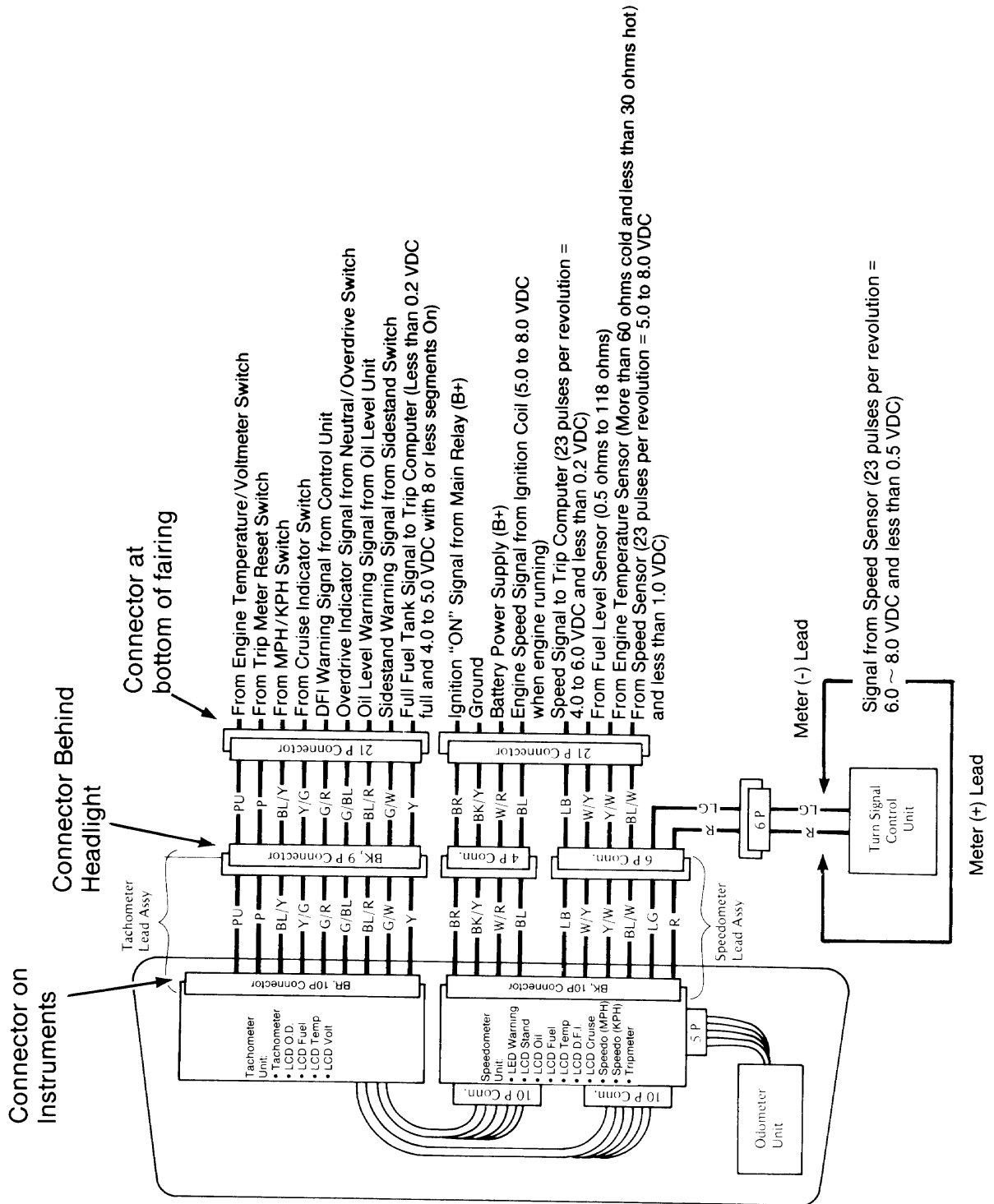





Voyager



AM Radio
FM Stereo Radio
Cassette Player
CB Radio
Intercom

Audio Systems

Operator's Manual

SAFETY AWARENESS

Whenever you see the symbols shown below, heed their instructions! Always follow safe operating and maintenance practices.

WARNING

- This warning symbol identifies special instructions or procedures which, if not correctly followed, could result in **personal injury, or loss of life.**

CAUTION

- This caution symbol identifies special instructions or procedures which, if not strictly observed, could result in **damage to or destruction of equipment.**

"NOTE"

- This note symbol indicates points of particular interest for more efficient and convenient operation.

NOTICE

THIS PRODUCT HAS BEEN MANUFACTURED FOR USE IN A REASONABLE AND PRUDENT MANNER BY A QUALIFIED OPERATOR.

FOREWORD

We wish to thank you for choosing the Kawasaki Voyager with its fine audio system. Your new Voyager audio system is the product of Kawasaki's advanced engineering, exhaustive testing, and continuous striving for superior reliability, safety and performance.

Read this Operator's Manual before operating your audio system so you will be thoroughly familiar with the proper operation of your audio system's controls, features, capabilities and limitations. Standard equipment includes an AM Radio, an FM Stereo Radio and a Cassette Player; a CB Radio and an Intercom are available separately as options.

Due to improvement in design and performance during production, in some cases there may be minor discrepancies between the actual audio system and the illustrations and text in this manual.

IMPORTANT NOTICE

Some states under various statutes prohibit the wearing of "headphones" or "headsets" while operating a motor vehicle. While the mounting of audio speakers in motorcycle helmets does not convert them to "headphones" or "headsets," some states may prohibit use of the Voyager "Ground Control" helmet sound system under such statutes. Kawasaki advises you to determine the legality of the "Ground Control" helmet sound system prior to using it in any state.

**KAWASAKI HEAVY INDUSTRIES. LTD.
MOTORCYCLE GROUP**

..... **TABLE OF CONTENTS**

SPECIFICATIONS	3
LOCATION OF PARTS	5
GENERAL INSTRUCTIONS	7
Operating Precautions	7
Theft Prevention	8
AM/FM STEREO RADIO	11
Features	11
AM/FM Stereo Radio Controls	11
Time Adjustment	13
How to Listen to the Radio	14
CASSETTE PLAYER	16
Features	16
Cassette Player Controls	16
Tape Information	19
How to Play the Cassette Player	20
CB RADIO	21
Features	21
CB Radio Controls	21
How to Operate the CB Radio	23
INTERCOM	25
Features	25
Intercom Controls	25
How to Use the Intercom	26
FULL SYSTEM OPERATION	27
Controls	27
AM/FM Stereo Radio and Cassette Player	29
CB Radio and Intercom	29
AM/FM Stereo Radio, Cassette Player and Intercom	30
AM/FM Stereo Radio, Cassette Player, Intercom and CB Radio	30
MAINTENANCE	32
Cleaning the Motorcycle	32
Cassette Player	32

//////////////////////////////////// SPECIFICATIONS //////////////////////////////////////

General	
Power supply: Voltage	12 V (10.8 to 15.6 V) DC, Negative ground
AM/FM Stereo Radio	
AM Radio:	
Circuit System	Superheterodyne
Tuning System	Electronic tuning
Noise Reduction System	Built-in (CZ2)
Receiving Range	530 to 1,620 kHz (10 kHz step)
Intermediate Frequency	450 kHz
Quieting Sensitivity	Less than 35 dB μ (at 20 dB S/N)
Selectivity	More than 20 dB
Distortion	Less than 5 %
Signal-to-Noise (S/N) Ratio	More than 40 dB
FM Stereo Radio:	
Circuit System	Superheterodyne
Tuning System	Electronic tuning
Noise Reduction System	Built-in (ACZ1)
Receiving Range	87.9 to 107.9 MHz (200 kHz step)
Intermediate Frequency	10.7 MHz
Quieting Sensitivity	Less than 15 dB μ (at 30 dB S/N)
Separation	More than 20 dB
Distortion	Less than 5 %
Signal-to-Noise (S/N) Ratio	More than 40 dB
Current Consumption (AM/FM):	0.7 A at maximum output 10 mA with back-up
Cassette Player	
Reproduction System	4 track, 2 channel, 2 program cassette stereo player (Monaural tape playable)
F.F., REW. Time	Less than 90 sec. (C-60 tape)
Wow and Flutter	Less than 0.3 % (weighted)
Current Consumption	0.3 A (maximum 2 A)

Control Mixer

“Ground Control” Helmet Sound
System:

Rated Output	0.5 W + 0.5 W (Load impedance = 8 ohms, Stereo)
Output Impedance	16 ohms
Mic Input Impedance	200 ohms
Mic Input Sensitivity	- 70 dBm

Power Amplifier

Circuit System	B.T.L. (Balanced Transformerless) circuit
Rated Output	12 W + 12 W (Load impedance = 4 ohms, 5 % distortion)
Output Impedance	4 ohms
Signal-to-Noise (S/N) Ratio	More than 50 dB
Current Consumption	4 A at maximum output

CB Radio

General:

Number of Channels	40 channels (26.965 to 27.405 MHz)
Noise Reduction System	Built-in (CZ2)
Modulation Type	Amplitude modulation
Antenna Impedance	50 ohms

Receiver:

Quieting Sensitivity	Less than 6 dB μ (at 10 dB S/N)
Intermediate Frequency	1st 10.695 MHz 2nd 455 kHz
Current Consumption	Less than 0.3 A

Transmitter:

Radio Frequency (R.F.) Output	4 W maximum (13.8 V)
Current Consumption	Less than 2 A

Speakers

Type	Cone type, 10 cm dia.
Rated Impedance	4 ohms
Reproduction Frequency	115 to 10,000 Hz

////////////////////// LOCATION OF PARTS ////////////////////////

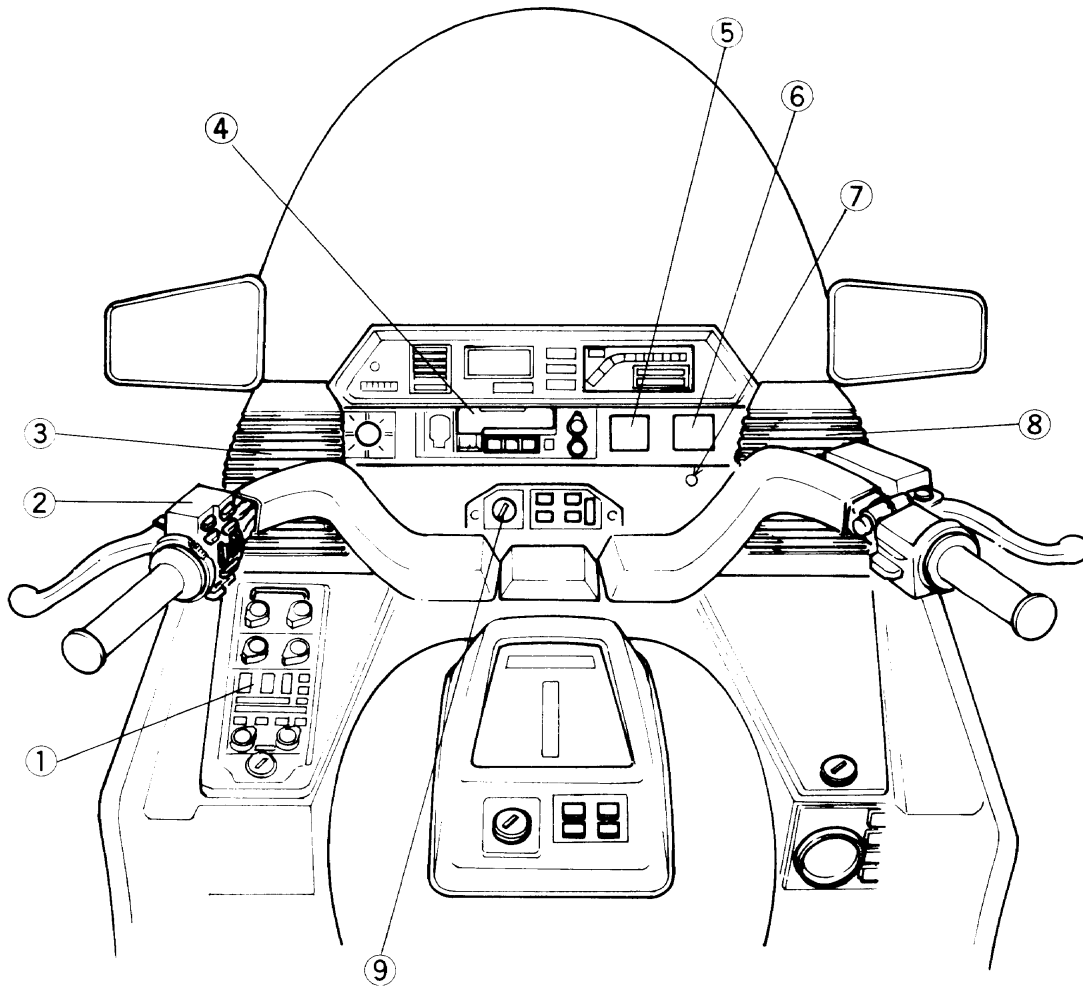

1. Control Unit (AM/FM Stereo Radio-STD,
CB Radio and Intercom-Optional)
2. Left Handlebar Switches
3. Left Speaker
4. Cassette Player and Controls
5. Clock/Radio Frequency Display
6. CB Display (Optional)
7. Speaker Switch for CB (Optional)
8. Right Speaker
9. Ignition Switch

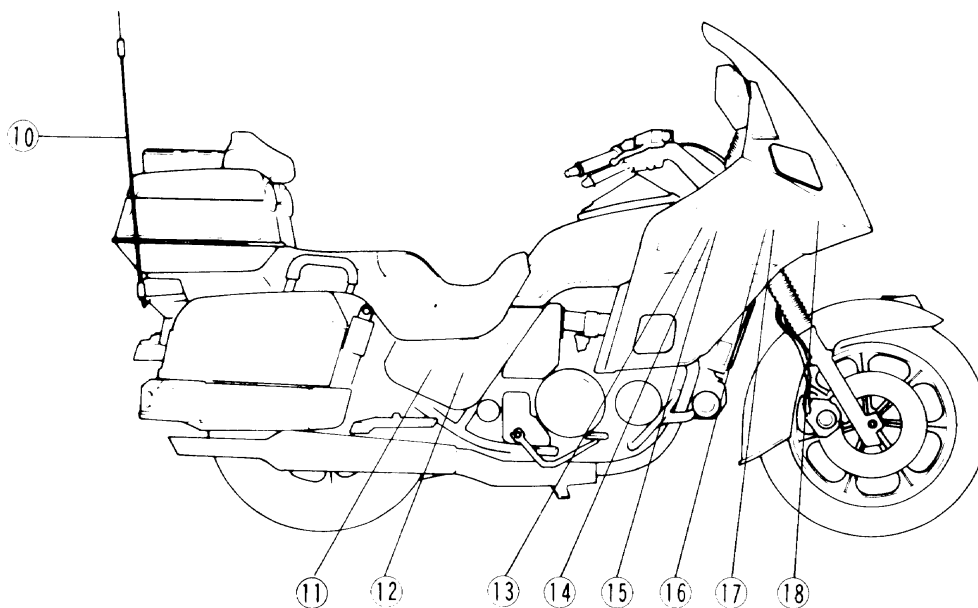

- | | |
|------------------------------|------------------------------------|
| 10. Antenna (for AM/FM/CB) | 15. Antenna Box (Optional—CB) |
| 11. Junction Box | 16. Low Booster |
| 12. Fuse Box | 17. Control Mixer |
| 13. CB Module (Optional) | 18. Super Sound Harness (Optional) |
| 14. Muting Box (Optional—CB) | |

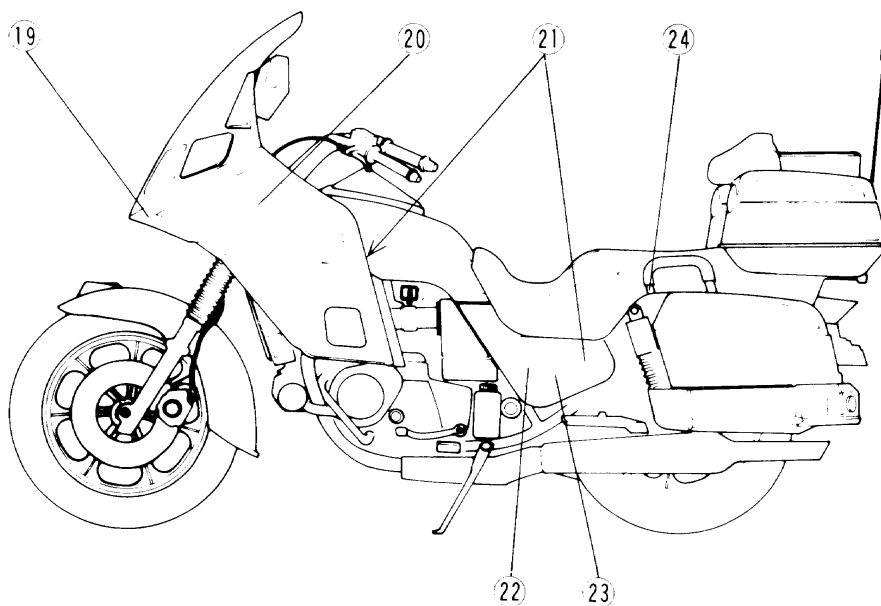

- | | |
|--------------------------|---|
| 19. Power Amplifier | 22. Battery |
| 20. Radio Tuner | 23. Accessory Relay |
| 21. DIN Plugs (Optional) | 24. Passenger Talk Switch (Optional—CB) |

GENERAL INFORMATIONS

Operating Precautions

There are a number of important precautions that are musts when operating the audio system. Learn and observe all the rules below.

WARNING

- Keep both hands on the handlebars at all times while riding. Don't remove your hands from the handlebar to adjust audio system controls. Make these adjustments before riding.

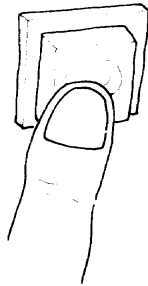

Adjust Controls Before Riding

- Do not operate the audio systems (AM radio, FM stereo radio, cassette player or optional sound devices) at volumes so loud that they interfere with your ability to hear sirens, horns, or other warning signals.

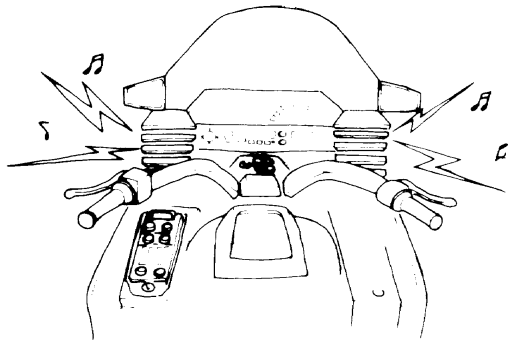

- Do not operate the audio systems at volumes so loud that they disturb other people.

CAUTION

- With the exception of genuine Kawasaki Parts and Accessories, Kawasaki has no control over the design or application of accessories. Kawasaki Parts and Accessories have been specially designed for use on Kawasaki motorcycles. We strongly recommend that all parts and accessories you add to your motorcycle be genuine Kawasaki components.

- Do not use any substitute for the standard fuse. If a fuse is blown, inspect the electrical system to determine the cause, and then replace it with a new one of the correct capacity.

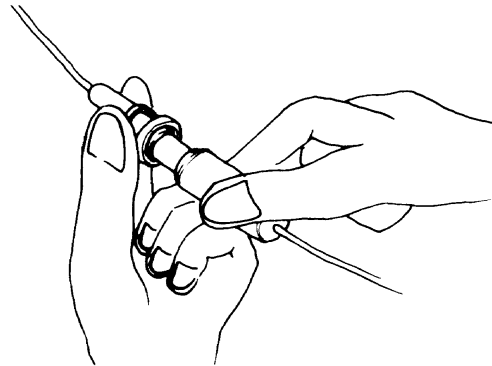

- The audio systems are designed for use with a 12 V DC negative ground system. Do not use the audio systems with other voltages or a positive ground system.

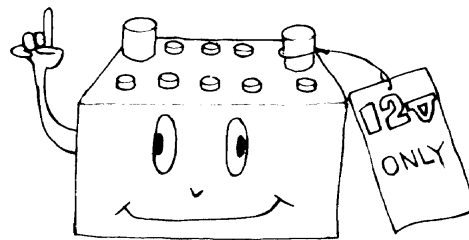

- If you use the AM/FM radio, cassette player or optional equipment for a long time with the engine stopped, the battery may become discharged. When you listen to the AM/FM radio, cassette player or optional equipment with the engine stopped, decrease the volume as for as possible. Increasing the volume increases the power consumption.

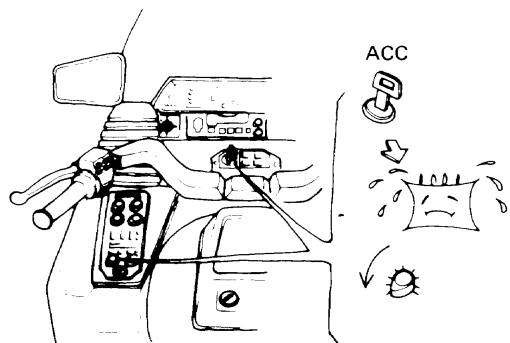

○When the ignition switch is turned OFF, the AM/FM radio preset memory and clock will continue to function with the back-up power supply circuit from the battery. But, reset is required when the battery becomes totally discharged or is disconnected.

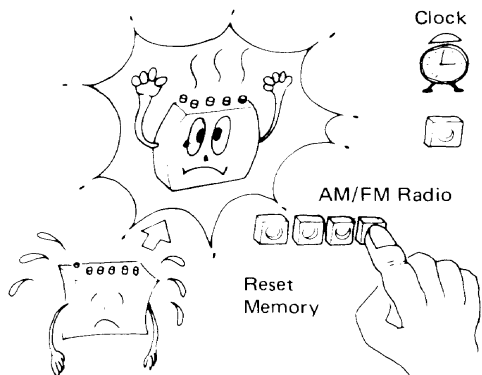

○USE UNGROUNDED SPEAKERS ONLY. Use 4 ohm speakers only. All speaker leads and terminals must be electrically isolated from chassis ground or amplifier will be damaged.

"NOTE"

○When the engine stop/starter switch is pushed to start the engine, the power for the audio system is cut off. This is to supply the sufficient power to the starter motor.

Theft Prevention

To help prevent theft, the control unit and antenna can be detached from the motorcycle and taken with you. Also, the cassette player can be covered with a lockable anti-theft cover.

CAUTION

○The control unit is designed to be water-resistant and dew-proof when it is correctly installed on the motorcycle. But once removed the control unit is not water-resistant and dew-proof. So, be sure to keep it in a dry place.

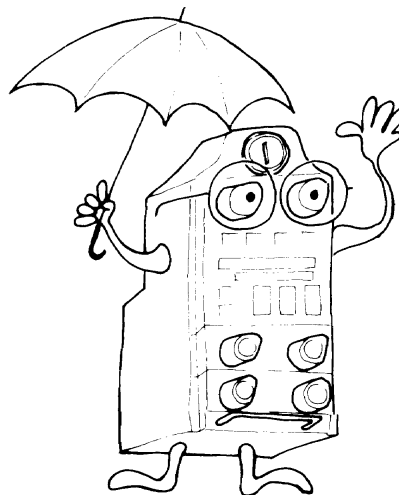

○Don't drop the control unit on a hard surface. Such a shock can damage it.

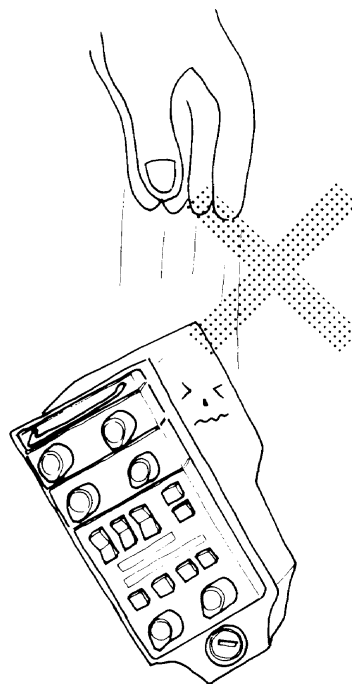

○To prevent damage to the audio systems, do not remove the control unit or the antenna when the ignition switch is in the "ON" or "ACC" position.

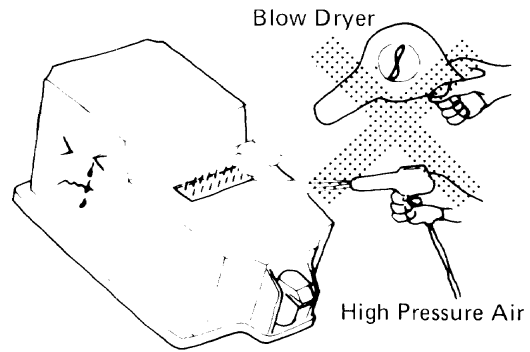

Control Unit:

Removal

- Insert the ignition switch key into the control unit lock, and turn the key fully clockwise.
- While holding the key in this position, pull the control unit upward using the key and handle as the handholds, and detach it from the motorcycle.
- Remove the key, and install the lid.

○Keep water and dirt from getting into the 34-pin control unit connector. Water and dirt may cause failure from improper contact. Also, take care not to bend the pins in the connector when removing the control unit.

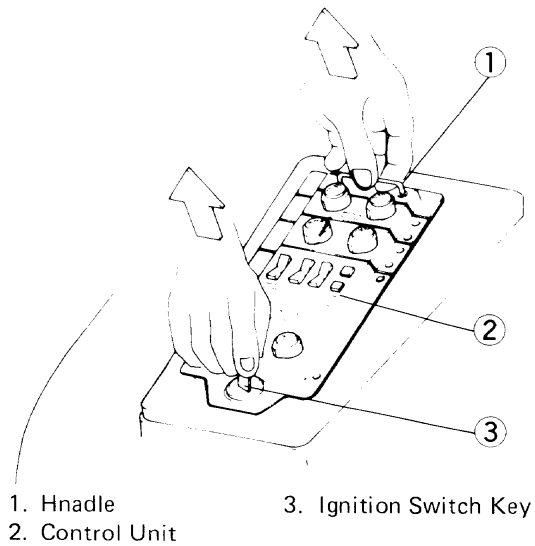
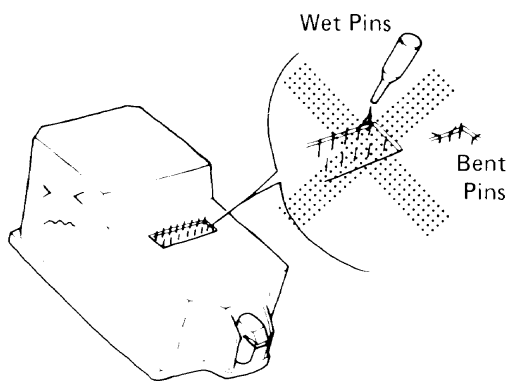

- 1. Handle
- 2. Control Unit
- 3. Ignition Switch Key

○If the 34-pin connector of the control unit gets wet, dry it with cloth or paper and leave it until it is completely dry. Hot air from a blow dryer or high pressure air should not be used to dry the 34-pin connector. The connector may deform or break.

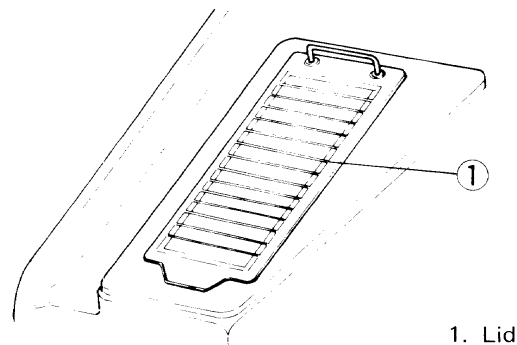

- 1. Lid

Installation

- Remove the lid and install the control unit upright.
- Be sure the 34-pin connector is properly engaged.
- Check that the control unit is securely locked into place.

Antenna:

Removal

- Turn the lower end of the antenna and remove the antenna from the motorcycle.

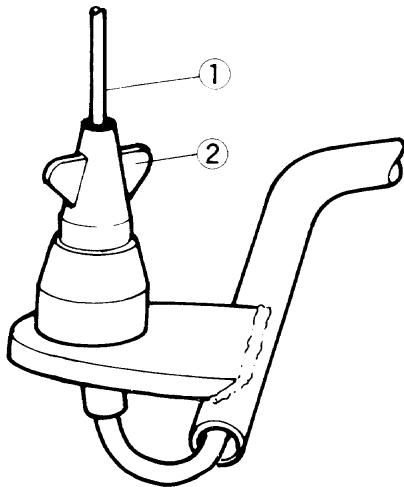

1. Antenna 2. Lower End

Installation Note

- Tighten the antenna securely so that it will not loosen while you are riding.

Cassette Player Anti-Theft Cover:

Installation

- Install the anti-theft cover on the cassette player by fitting the tab at the end of the cover into the groove of the cassette player. Swing the cover over the face of the cassette player and push on the cover to lock it.
- Check that the cover is securely locked into place.

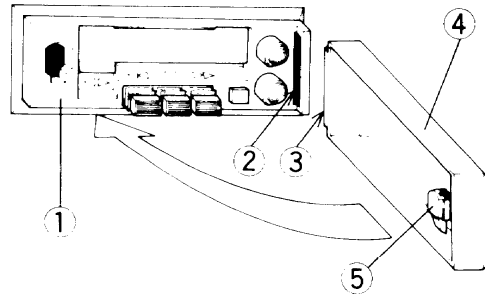

1. Cassette Player 4. Anti-Theft Cover
 2. Groove 5. Lock
 3. Tab

Removal

- Insert the ignition switch key into the anti-theft cover lock.
- Turn the key fully clockwise, and remove the cover from the cassette player.

AM/FM STEREO RADIO

Features

- AM/FM stereo electronic tuner, PLL (Phase Locked Loop) frequency synthesizer system with clock function
- Digital quartz clock, 12-hour indication
- Easy-to-read LCD digital display
- Anti-vibration and water-resistant construction
- Manual tuning, preset tuning, and auto seek tuning
- Muting and auto seek tuning switches are on the handlebar
- Four FM and four AM stations can be preset into memory
- Control unit and antenna can be detached to prevent theft
- SASC (Signal Actuated Stereo Control) circuit is provided in FM

This circuit is used to further improve FM reception and widen the service area. Stereo mode is automatically selected when FM stereo signal is being received. However, if the signal is too weak to provide proper reception, the monaural mode is automatically selected to obtain improved reception with low noise. Comfortable FM reception with low noise can thus be enjoyed.

AM/FM Stereo Radio Controls

Left Handlebar Switches:

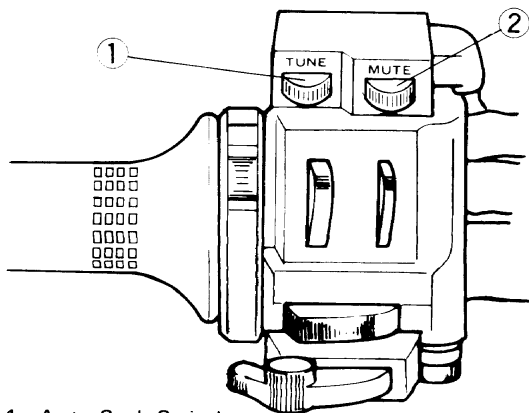

- 1. Auto Seek Switch
- 2. Muting Switch

1. Auto Seek Switch

Turn on this switch to move the radio frequency up to the next listenable station. If you want to seek and tune in another station, turn on the switch again.

“NOTE”

When the radio passes the last listenable station at the highest frequency, it starts to seek the first listenable station beginning at the lowest frequency.

2. Muting Switch

Turn on the muting switch to decrease the radio volume instantly when listening to the radio from the fairing-mounted speakers.

AM/FM Stereo Radio Control Unit:

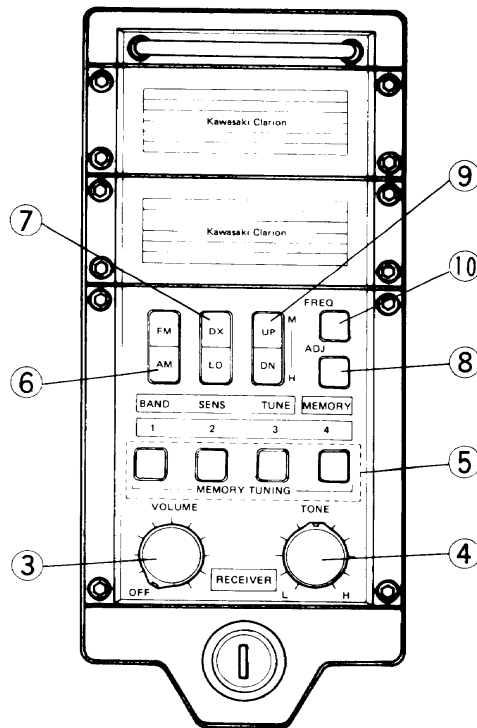

- 3. Power Switch/ Volume Control
- 4. Tone Control
- 5. Preset Tuning Buttons
- 6. Band Select Switch
- 7. DX/LO Switch
- 8. Memory/Adjusting Button
- 9. Manual Tuning/ Time Adjusting Switch
- 10. Frequency Readout Button

3. Power Switch/Volume Control

(a) Power Switch

To Supply Power

- Turn the ignition switch to the "ACC" or "ON" position. At this time, the control unit and clock/radio frequency display illuminations will light.
- Rotate the power switch clockwise to turn on the radio, you will hear a click when the power comes on.

"NOTE"

- *The clock/radio frequency display will show the radio frequency for about 5 seconds after the power is turned on and then will show the time.*

To Turn Off Power

- Rotate the power switch counterclockwise until a click is heard.
- Turn off the ignition switch. At this time, the control unit and clock/radio frequency display illuminations will go out.

(b) Volume Control

Rotate the volume control clockwise to increase volume, or counterclockwise to decrease volume.

4. Tone Control

Rotate the tone control clockwise to emphasize treble. Treble is attenuated by rotating the control counterclockwise.

5. Preset Tuning Buttons

Four AM stations and four FM stations (one AM and one FM for each preset tuning button) can be preset in the memory. After presetting, push the appropriate preset tuning button to tune in the desired station.

6. Band Select Switch

Push the rocker type band select switch to "AM" or "FM". At this time, the AM or FM indicator will appear on the clock/radio frequency display.

7. DX/LO (Distance/Local) Switch

This rocker type DX/LO switch is available only when you seek and tune in the station using the auto seek switch. When the station signal is weak, push the switch to "DX". When the

station signal is strong, push the switch to "LO". At this time, the local indicator will appear on the clock/radio frequency display.

8. Memory/Adjusting Button

This button is used to adjust the time or to preset an AM or FM station in the memory. When the time is indicated on the clock/radio frequency display, the memory indicator will appear on the display while this button is being pushed. When the radio frequency is indicated on the display, the memory indicator will appear on the display for about 5 seconds after this button is pushed.

9. Manual Tuning/Time Adjusting Switch

Push this rocker type switch to tune in the desired station. Pushing the switch to "UP" moves the frequency from low to high, and pushing the switch to "DN" moves the frequency from high to low. Pushing the switch momentarily increases or decreases the frequency by 10 kHz for AM or by 200 kHz for FM. Pushing and holding the switch increases or decreases the frequency continuously in 10 kHz steps for AM or in 200 kHz steps for FM.

"NOTE"

- *The clock/radio frequency display will show the frequency for about 5 seconds after this switch is released; then it will return to showing the time. With the memory/adjusting button (#8) depressed, push this rocker type switch to "M (UP)" to adjust the minutes or to "H (DN)" to adjust the hour. Pushing the switch momentarily advances the hour or minute step by step. Pushing and holding the switch advances the hour or minutes continuously.*

10. Frequency Readout Button

Push this button for the clock/radio frequency display to show the radio frequency. The frequency will be indicated for about 5 seconds after this button is pushed; then the display will return to showing the time.

Clock/Radio Frequency Display:

This display indicates both the time and radio frequency. Ordinarily the time is indicated on the display.

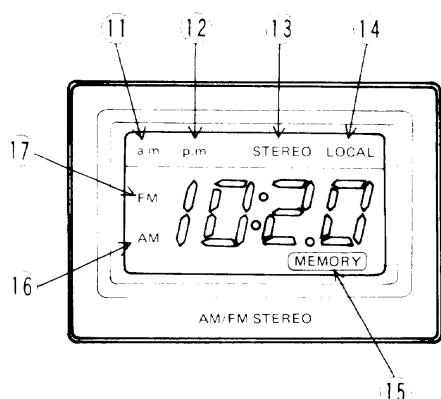

- 11. a.m. Indicator
- 12. p.m. Indicator
- 13. Stereo Indicator
- 14. Local Indicator
- 15. Memory Indicator
- 16. AM Indicator
- 17. FM Indicator

11. a.m. Indicator

The a.m. indicator will appear on the display during the first 12 hours of the day.

12. p.m. Indicator

The p.m. indicator will appear on the display during the second 12 hours of the day.

13. Stereo Indicator

The stereo indicator will appear on the display when the FM stereo signal is being received.

14. Local Indicator

The local indicator will appear on the display when the DX/LO switch (#7) is in the "LO" position.

15. Memory Indicator

When the time is indicated on the clock/radio frequency display, the memory indicator will appear on the display while the memory/adjusting button (#8) is being pushed. When the radio frequency is indicated on the display, the memory indicator will appear on the display for about 5 seconds after the memory/adjusting button (#8) is pushed.

16. AM (amplitude modulation) Indicator

The AM indicator will appear on the display while the AM radio signal is being received.

17. FM (frequency modulation) Indicator

The FM indicator will appear on the display while the FM radio signal is being received.

Time Adjustment

When the ignition switch is in the "OFF" position, the clock functions with the back-up power supply circuit from the battery. But, reset is required when the battery becomes discharged or is disconnected.

"NOTE"

When the battery becomes discharged or is disconnected, the time display is reset to "1:00 a.m."

- Turn the ignition switch to the "ACC" or "ON" position.
- Rotate the power switch clockwise to turn on the radio, and check that time is displayed.
- Depress the memory/adjusting button. At this time, the memory indicator will appear on the display.
- With the memory/adjusting button depressed, push the manual tuning/time adjusting switch to "M (UP)" to adjust the minutes or to "H (DN)" to adjust the hour. Pushing the switch momentarily advances the hour or minute step by step. Pushing and holding the switch advances the hour or minutes continuously.
- Check that the a.m. or p.m. indicator is appropriate for the time of day. If it is not, advance the time by 12 hours.

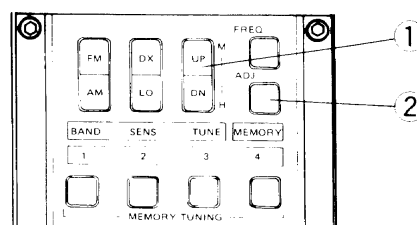

- 1. Manual Tuning/Time Adjusting Switch
- 2. Memory/Adjusting Button

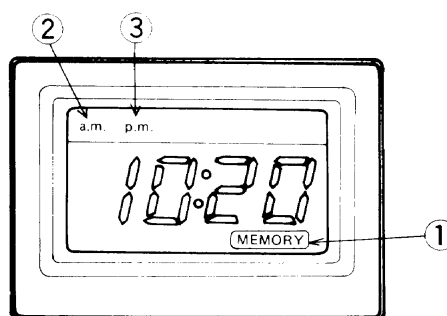

- 1. Memory Indicator
- 2. a.m. Indicator
- 3. p.m. Indicator

.....
How to Listen to the Radio

Tuning:

The Voyager AM/FM stereo radio features manual tuning, auto seek tuning, and preset tuning.

Manual Tuning

- Turn the ignition switch to the “ACC” or “ON” position.
- Rotate the power switch clockwise to turn on the radio.
- Push the manual tuning/time adjusting switch to tune in the desired station. Pushing the switch to “UP” moves the frequency from low to high, and pushing the switch to “DN” moves the frequency from high to low. Pushing the switch momentarily increases or decreases the frequency by 10 kHz for AM or by 200 kHz for FM. Pushing and holding the switch increases or decreases the frequency continuously in 10 kHz steps for AM or in 200 kHz steps for FM.

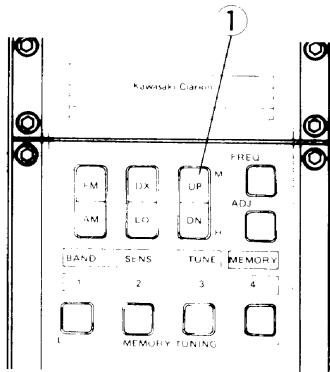

1. Manual Tuning/Time Adjusting Switch

Auto Seek Tuning

- Turn the ignition switch to the “ACC” or “ON” position.
- Rotate the power switch clockwise to turn on the radio.
- Turn on the auto seek switch to move the radio frequency up to the next listenable station.
- Once the station selection is completed, the display stops and indicates the frequency selected.
- If you want to seek and tune in another station, turn on the switch again.

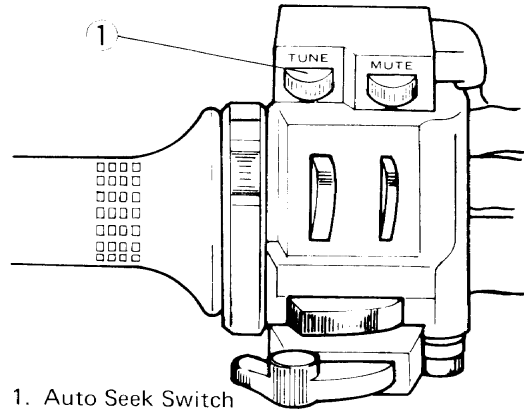

1. Auto Seek Switch

“NOTE”

○ When the radio passes the last listenable station at the highest frequency, it starts to seek the first listenable station beginning at the lowest frequency.

Preset Tuning

“NOTE”

○ When the battery becomes discharged or is disconnected, the preset memory is erased and following frequency is set into memory.

Band	Preset Tuning Button			
	1	2	3	4
AM	530 kHz	600 kHz	1,000 kHz	1,400 kHz
FM	87.9 MHz			

- Turn the ignition switch to the “ACC” or “ON” position.
- Rotate the power switch clockwise to turn on the radio.
- Select the AM or FM band using the band select switch.
- Tune in the desired station (auto seek tuning or manual tuning), and check that the radio frequency is shown on the display.
- Push the memory/adjusting button. At this time, the memory indicator will appear on the display for about 5 seconds. The memory can be set only while the memory indicator and radio frequency appear on the display.
- While the memory indicator and radio frequency appear on the display, push any one of the four preset tuning buttons. When the station is preset in the memory, the memory indicator will disappear.

- You can preset into memory 4 AM and 4 FM stations (one AM and one FM station for each preset tuning button).
- After presetting, push the appropriate preset tuning button to tune in the desired station.

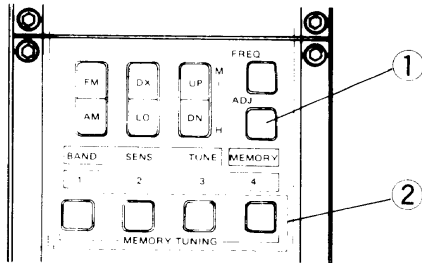

1. Memory/Adjusting button
2. Preset Tuning Buttons

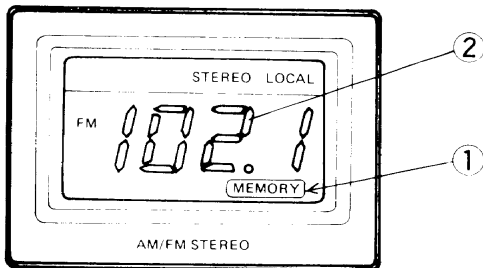

1. Memory Indicator
2. Radio Frequency Display

Listening to the Radio:

WARNING

- Carefully read the "GENERAL INSTRUCTIONS" chapter in this manual before operating the radio. Learn and observe all the rules.

"NOTE"

- The radio can not be operated while the cassette player is in use.
- The radio can be heard even if time is shown on the display.
- With the radio is once turned off and then turned on again, memory in the radio will automatically return to the last station tuned in.
- The super sound harness (optional) gives you the same excitement as you would experience at the live concert.
- Turn the ignition switch to the "ACC" or "ON" position.
- Rotate the power switch clockwise to turn on the radio.
- Select the band (AM or FM).
- Tune in the desired station (auto seek tuning, preset tuning, or manual tuning).
- Adjust the volume and tone controls.

//////////////////// CASSETTE PLAYER //////////////////////

.....
Features

- Auto reverse mechanism
- Anti-vibration and water-resistant construction
- Anti-theft cover with lock

.....
Cassette Player Controls

Cassette Player:

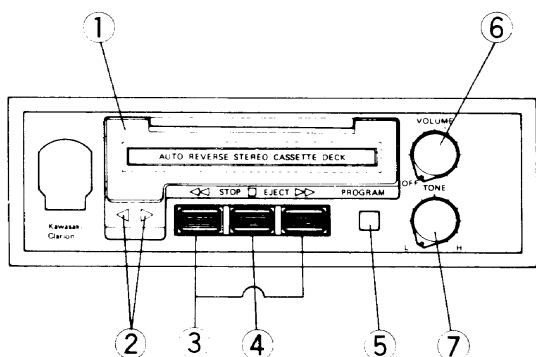

1. Tape Slot Door
2. Program Indicators
3. F.F./Rew. Buttons
4. Stop/Eject Button
5. Program Change Button
6. Power Switch/Volume Control
7. Tone Control

1. Tape Slot Door

Open this door to insert or remove a cassette.



- Be sure to keep the tape slot door closed except when inserting or removing a cassette to prevent dirt and water from entering and damaging the cassette player.
- Always remove a cassette from the player when it is not in play.

Loading a Cassette

- Open the tape slot door.
- Insert the cassette into the tape slot with the exposed tape side facing the slot.
- Close the tape slot door.

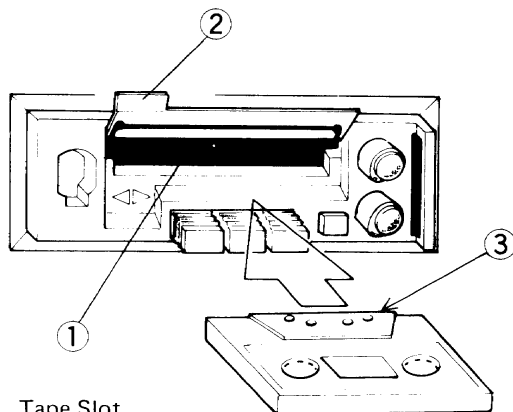

1. Tape Slot
2. Tape Slot Door
3. Exposed Tape Side



- A tape that is loose or slack inside the cassette case may become wound around the capstan or pinch roller. To avoid this problem, tighten the tape by using a pencil or other suitable implement as shown.

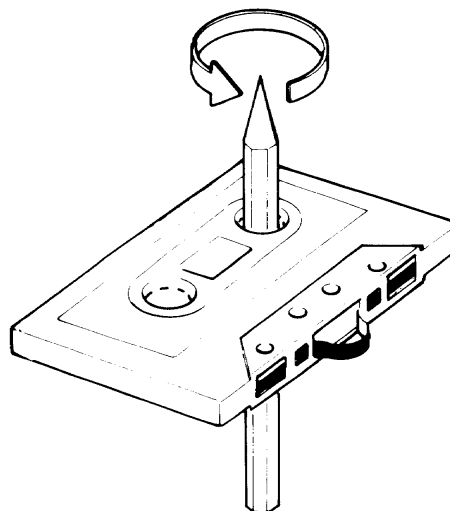

Removing a Cassette

- Open the tape slot door.
- Push the stop/eject button (#4) firmly and remove the cassette.
- Close the tape slot door.

2. Program Indicator (◀ ▶)

The two program indicators (◀ ▶) show the direction of tape movement and the program being played (A or B).

(a) The ◀ Indicator

The ◀ indicator lights when the tape is moving from right to left and the program recorded on the side facing up (side A illustrated below) is playing.

(b) The ▶ Indicator

The ▶ indicator lights when the tape is moving from left to right and the program recorded on the side facing down is playing.

3. F.F./Rew. Buttons (Fast Forward/Rewind)

These buttons move the tape rapidly in either direction. They are locking and, therefore, do not have to be held continuously while advancing or rewinding the tape.

Advancing or Rewinding the Tape

- With a cassette tape playing, check the program indicator to determine which direction the tape is moving.

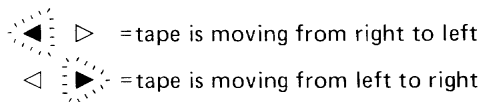

- If the ◀ indicator is lit, push the left F.F./Rew. button to advance the tape to the end of the program. Push the right F.F./Rew. button to rewind the tape to the beginning of the program.

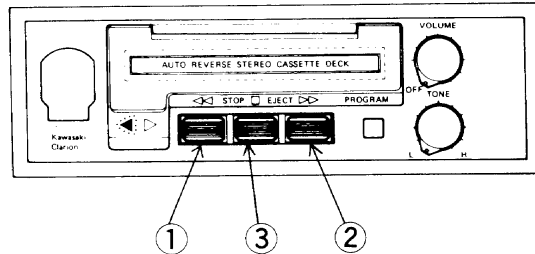

1. Push this button to advance the tape.
2. Push this button to rewind the tape.
3. Stop/Eject Button

- If the ▶ indicator is lit, push the right F.F./Rew. button to advance the tape and push the left F.F./Rew. button to rewind the tape.

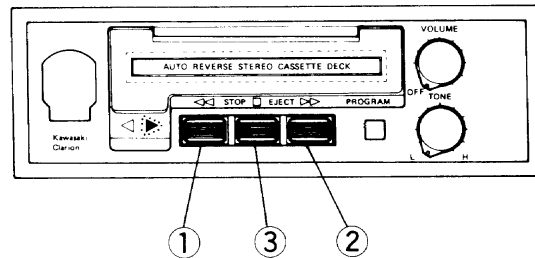

1. Push this button to rewind the tape.
2. Push this button to advance the tape.
3. Stop/Eject Button

Cassette with Side A Facing Up	Program Indicator	Side Playing
		Side A
		Side B

"NOTE"

- To cancel fast feeding of the tape once a F.F./ Rew. button is depressed, lightly push the stop/eject button (#4).
- Fast feeding of the tape will be cancelled and play back will begin when the tape is advanced or rev:ound to the end.

4. Stop/Eject Button

This button cancels the fast forward or rewinding of the tape when pushed lightly. It ejects the cassette when pushed firmly.

Ejecting the Cassette

- Open the tape slot door.
- Push the stop/eject button firmly to eject the cassette.
- Take the cassette out of the tape slot.
- Close the tape slot door.

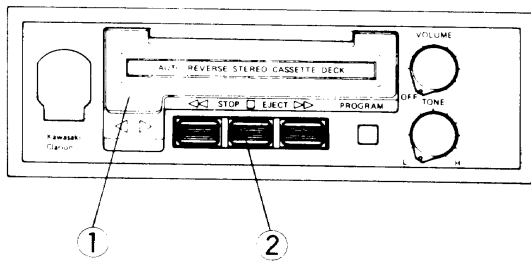

1. Tape Slot Door
2. Stop/Eject Button

5. Program Change Button

Push this button to change the program.

Changing Program

- Push the program change button to switch cassette programs. It is not necessary to remove the cassette and turn it over.

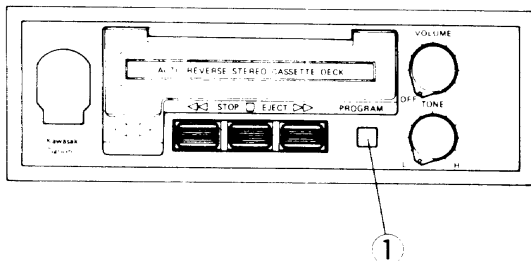

1. Program Change Button

"NOTE"

- The program indicators will show the change in tape movement direction when you push the program change button.
- When the tape reaches the end during normal play or when advanced with a F.F./Rew. button (#3), the auto-reverse mechanism will begin play in the opposite direction. The program indicators will change also to show that the program has changed.

6. Power Switch/Volume Control

(a) Power Switch

To Supply Power

- Turn the ignition switch to the "ACC" or "ON" position.
- Rotate the power switch clockwise to turn on the cassette player. You will hear a click when the power comes on.

To Turn Off Power

- Rotate the power switch counterclockwise until a click is heard.
- Turn off the ignition switch.

(b) Volume Control

Rotate the volume control clockwise to increase volume, or counterclockwise to decrease volume.

7. Tone Control

Rotate the tone control clockwise to emphasize treble. Treble is attenuated by rotating the control counterclockwise.

Left Handlebar Switch:

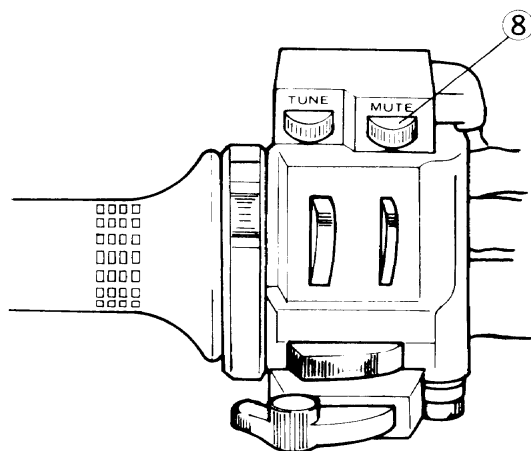

8. Muting Switch

8. Muting Switch

Turn on the muting switch to decrease the volume instantly when listening to the cassette player from the fairing-mounted speakers.

Not Recommended

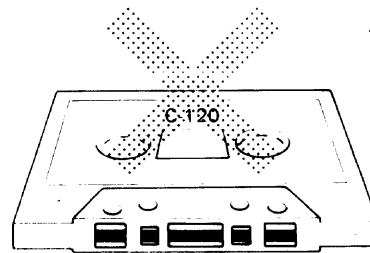

3. Do not store the tapes in the following areas.
- a) On top of heaters, in direct sunlight, or in any other high temperature area.

.....
Tape Information

1. Cassette tape is wound on reels in a special convenient case that is easily inserted into the cassette deck. Tape width, cassette case shape and size, and tape speed are standardized for compatibility. The standard C-60 cassette tape contains enough tape for 60 minutes of recording. The C-30, C-45, C-90 and C-120 cassettes contain enough tape for 30, 45, 90 and 120 minutes respectively. (All times are total times of both sides of the tape.)
2. Although the quality of most cassette tapes is quite high, the following suggestions may help to avoid some possible cassette problems.
 - a) Be careful of cassettes that appear to be warped or have deformities in the case shape. These deformities can cause uneven tape movement and noise due to the tape rubbing on the cassette case.
 - b) The C-120 tapes are extremely thin and weak, and the magnetic coating is also thin. These tapes may cause distorted sound and also may wrap around the capstan causing jamming. C-120 tapes, therefore, are not recommended for use in this tape player.

NO

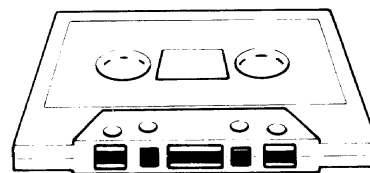

- b) Near any strong magnetic fields.

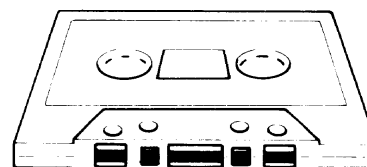

OK

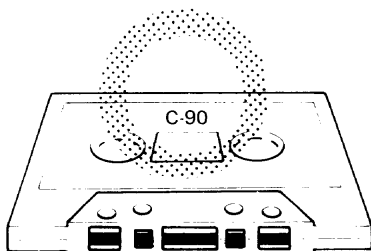

NO

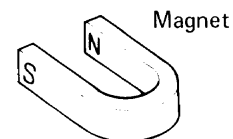

- c) High humidity areas.

How to Play the Cassette Player

WARNING

- Carefully read the "GENERAL INSTRUCTIONS" chapter in this manual before operating the cassette player. Learn and observe all the rules.

CAUTION

- Be sure to keep the tape slot door closed except when inserting or removing a cassette to prevent dirt and water from entering and damaging the tape player.
- Always remove a cassette from the player when it is not in play.

"NOTE"

- The radio cannot be operated while the cassette player is in use.*
- The super sound harness (optional) gives you the same excitement as you would experience at the concert.*

Playing a Cassette

- Turn the ignition switch to the "ACC" or "ON" position.
- Rotate the power switch clockwise to turn on the cassette player.
- Open the tape slot door, and insert a cassette into the tape slot with the exposed tape side facing the slot. At this time, a program indicator will light and play of the tape will automatically start.
- Close the tape slot door, and select the program.
- Adjust the volume and tone controls.

..... **CB (Citizens Band) RADIO**

.....
Features

- 40-channel CB transceiver
- Easy-to-read LCD digital channel display
- Anti-vibration and water-resistant construction
- Noise reduction circuit
- Transmission and channel selection by switches on handlebar
- Squelch control

.....
CB Radio Controls

Control Unit:

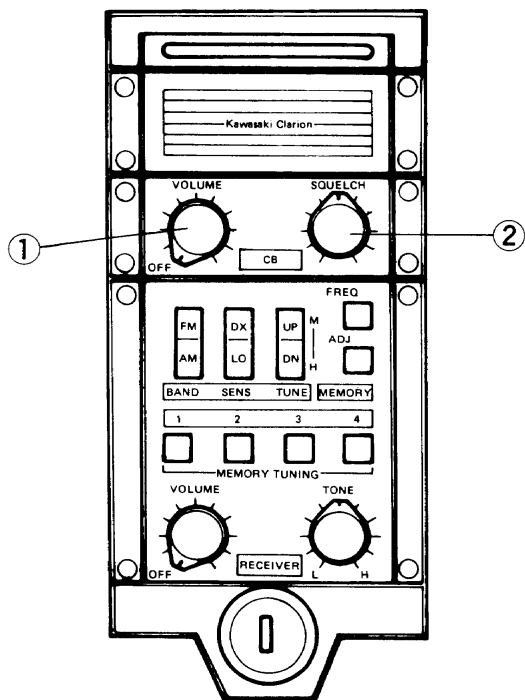

1. Power Switch/Volume Control
2. Squelch Control

1. Power Switch/Volume Control

(a) Power Switch

To Supply Power

- Turn the ignition switch to the "ACC" or "ON" position. At this time, the control unit illumination will light.
- Rotate the power switch clockwise to turn on the CB radio. You will hear a click when the power comes on. At this time, the CB display illumination will light and the CB and channel indicators (#9 & #10) will appear on the CB display.

To Turn Off Power

- Rotate the power switch counterclockwise until a click is heard. At this time, the CB display illumination will go out and the CB and channel indicators on the display will disappear.
- Turn off the ignition switch. At this time, the control unit illumination will go out.

(b) Volume Control

Rotate the volume control clockwise to increase the receiver volume, or counterclockwise to decrease the receiver volume.

2. Squelch Control

This control is used to eliminate the noise. Turn this control clockwise until the noise is eliminated.

Left Handlebar Switches:

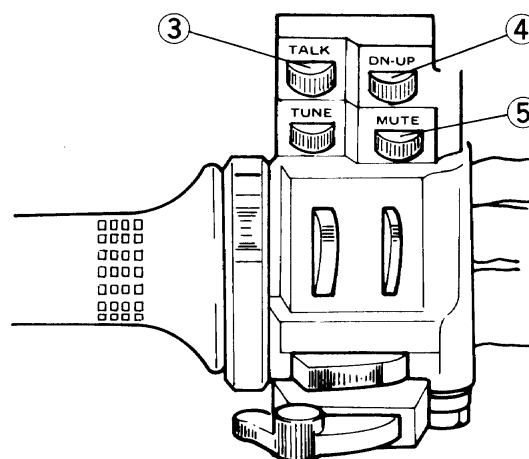

3. Rider Talk Switch
4. Channel Select Switch
5. Muting Switch

3. Rider Talk Switch

Turn on this switch to activate the transmitter. At this time, the TX indicator (#11) will appear on the display. Both this switch and passenger talk switch (#8) must be released to activate the receiver.

4. Channel Select Switch

Select the channel by pushing this switch. Pushing the switch to "UP" or "DN" moves the channel (frequency) up or down respectively. Pushing the switch momentarily changes the channel to the next one. Pushing and holding the switch changes channels continuously.

5. Muting Switch

Turn on the muting switch to decrease receiving volume instantly.

Other Switches and DIN Plugs:

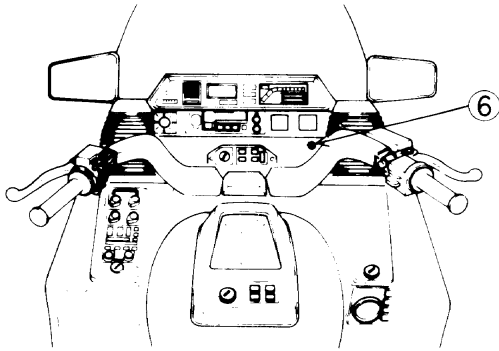

6. Speaker Switch for CB

6. Speaker Switch for CB

You will receive signals with both the fairing-mounted speakers and the "Ground Control" helmet sound system when this switch is turned on. Turn off this switch to switch off the fairing-mounted speakers.

7. DIN Plugs

Two DIN plugs are provided for connecting the "Ground Control" helmet sound system.

8. Passenger Talk Switch

Turn on this switch to activate the transmitter. At this time, the TX indicator (#11) will appear on the display. Both this switch and rider talk switch (#3) must be released to activate the receiver.

CB Display:

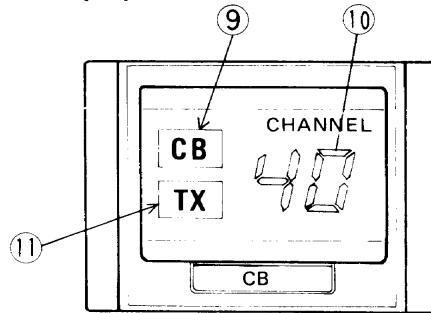

9. CB Indicator
10. Channel Indicator

11. TX Indicator

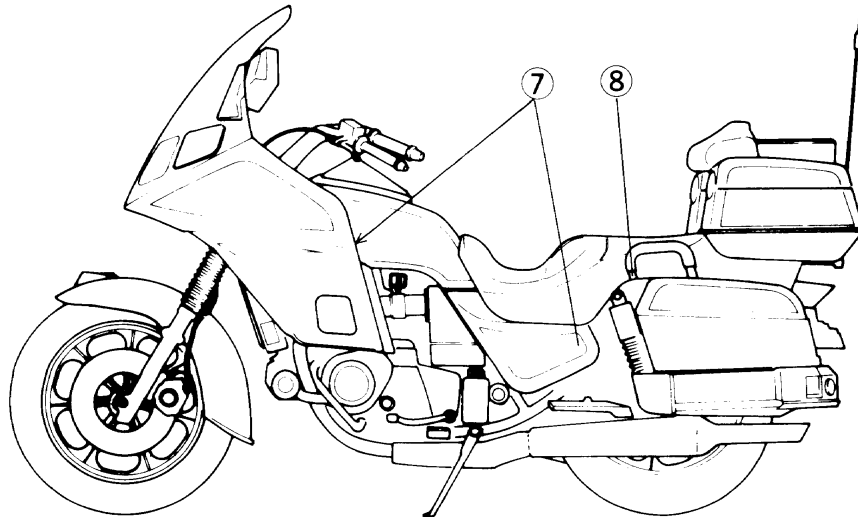

7. DIN Plugs
8. Passenger Talk Switch

9. CB Indicator

The CB indicator appears on the display while power is supplied to the CB radio.

10. Channel Indicator

The channel indicator shows the selected channel (frequency) on the display while power is supplied to the CB radio.

"NOTE"

○When the battery becomes discharged or is disconnected, the channel indicator is reset to "CHANNEL 1".

Channel:	Frequency (Megahertz)
1	26.965
2	26.975
3	26.985
4	27.005
5	27.015
6	27.025
7	27.035
8	27.055
9	27.065
10	27.075
11	27.085
12	27.105
13	27.115
14	27.125
15	27.135
16	27.155
17	27.165
18	27.175
19	27.185
20	27.205
21	27.215
22	27.225
23	27.255
24	27.235
25	27.245
26	27.265
27	27.275
28	27.285
29	27.295
30	27.305
31	27.315
32	27.325
33	27.335
34	27.345
35	27.355
36	27.365
37	27.375
38	27.385
39	27.395
40	27.405

11. Transmission (TX) Indicator

The TX indicator appears on the display while the rider and/or passenger are transmitting.

How to Operate the CB Radio

WARNING

- This CB radio has been approved by the Federal Communications Commission (F.C.C.) in the U.S.A. and the Department Of Communications (D.O.C.) in Canada, and has the "type acceptance" labels on it. Before operating a CB transmitter in the U.S.A. or Canada, you must have authority from the F.C.C. in the U.S.A. or the D.O.C. in Canada. Also, you must agree to follow the rules set by the F.C.C. in the U.S.A. or D.O.C. in Canada. Read the rules carefully. Following them is the least you can do to become a good CBer.
- Carefully read the "GENERAL INSTRUCTIONS" chapter in this manual before operating the CB radio. Learn and observe all the rules.

Operating the CB Radio

- Turn the ignition switch to the "ACC" or "ON" position.
- Rotate the power switch clockwise to turn on the CB radio.
- Set the speaker switch for CB to listen from (1) both the fairing-mounted speakers and the "Ground Control" helmet sound system or from (2) the "Ground Control" helmet sound system alone.
- Turn the squelch control counterclockwise all the way.
- Select the desired channel.

"NOTE"

○With the CB radio is once turned off and then turned on again, memory in the CB radio will automatically return to the last channel selected.

- Turn the volume control clockwise a little. At this time, receiving signals or noise will be heard.
- Turn the squelch control clockwise until the noise is eliminated.
- Adjust the CB volume control to the desired sound level.
- To transmit messages on the CB radio, turn on the rider talk switch, passenger talk switch or both. The talk switches must be released to activate the receiver.

"NOTE"

- *You can receive CB transmissions and listen to the AM/FM stereo radio or cassette player at the same time.*
- *The AM/FM stereo radio or cassette player volume will be muted automatically when transmitting or receiving CB messages.*

INTERCOM

Features

- Rider and passenger can communicate while listening to the AM/FM stereo radio, cassette player, and/or CB radio.
- Speaker select switch.
- Muting level control

1. Power Switch/Volume Control

(a) Power Switch

To Supply Power

- Turn the ignition switch to the "ACC" or "ON" position. At this time, the control unit illumination will light.
- Rotate the power switch clockwise to turn on the intercom. You will hear a click when the power comes on.

To Turn Off Power

- Rotate the power switch counterclockwise until a click is heard.
- Turn off the ignition switch. At this time, the control unit illumination will go out.

Intercom Controls

Control Unit:

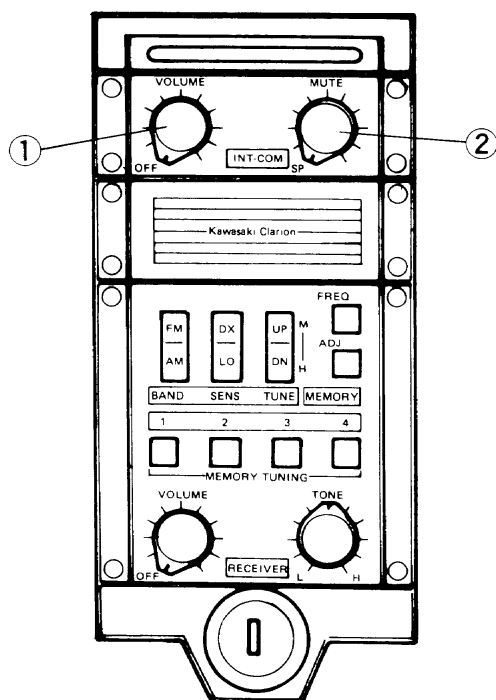

1. Power Switch/Volume Control
2. Speaker Select Switch/Muting Level Control

(b) Volume Control

Rotate the volume control clockwise to increase volume, or counterclockwise to decrease volume.

2. Speaker Select Switch/Muting Level Control

(a) Speaker Select Switch

Rotate this switch all the way counterclockwise to listen to the AM/FM stereo radio or cassette player from the fairing-mounted speakers only. Rotate this switch between the full clockwise and counterclockwise positions to listen from the "Ground Control" helmet sound system only.

(b) Muting Level Control

Rotate the muting level control between the full clockwise and counterclockwise positions to adjust for the speaking volume required to mute the sound from the AM/FM stereo radio or cassette player. Turn this control clockwise until the AM/FM stereo radio or cassette player is muted by normal speaking but is not muted by environmental noise.

3. DIN Plugs

Two DIN plugs are provided for connecting the "Ground Control" helmet sound system.

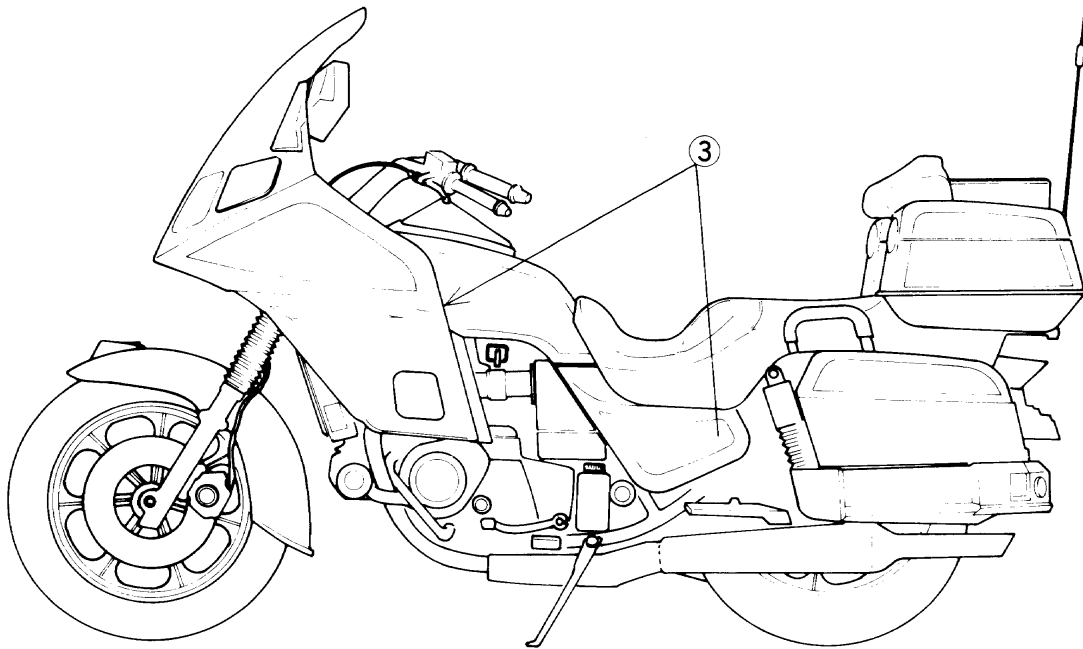
DIN Plugs:

3. DIN Plugs

.....

How to Use the Intercom

.....

WARNING

○Carefully read the “GENERAL INSTRUCTIONS” chapter in this manual before using the intercom. Learn and observe all the rules.

- Turn the ignition switch to the “ACC” or “ON” position.
- Rotate the power switch clockwise to turn on the intercom.
- Adjust the intercom volume to the desired sound level.
- If you are using the intercom while listening to the AM/FM stereo radio or cassette player at the same time, adjust the muting level. Adjust the muting level control so that the AM/FM stereo radio or cassette player is muted by normal speaking but is not muted by environmental noise.

“NOTE”

○When the AM/FM stereo radio or cassette player is muted by environmental noise, turn the muting level control counterclockwise and/or decrease the intercom volume.

//////////////////// FULL SYSTEM OPERATION //////////////////////

This chapter explains the procedures for operating the audio systems in combination with each other.

WARNING

○Carefully read the “GENERAL INSTRUCTIONS” chapter in this manual before operating the audio systems. Learn and observe all the rules.

Control Unit:

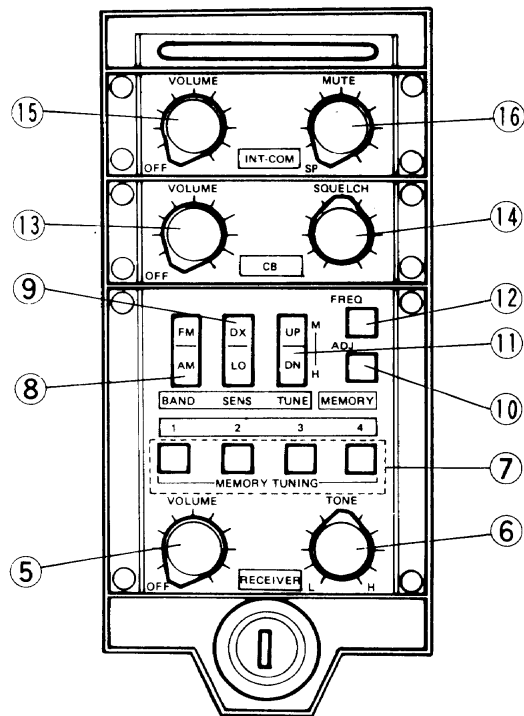

.....
Controls
.....

Refer to the individual component chapters for descriptions of the control functions.

Left Handlebar Switches:

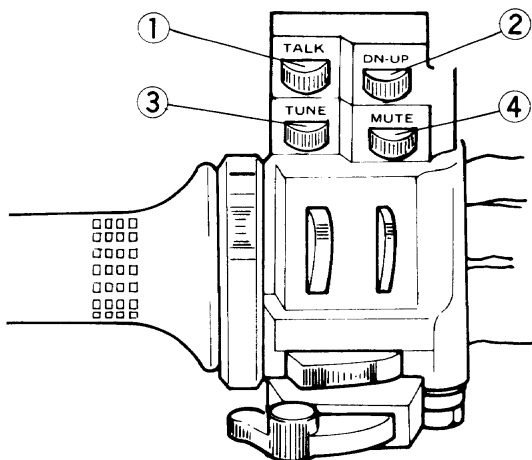

- 1. Rider Talk Switch (CB Radio)
- 2. Channel Select Switch (CB Radio)
- 3. Auto Seek Switch (AM/FM Stereo Radio)
- 4. Muting Switch (AM/FM Stereo Radio, Cassette Player and CB Radio)

- 5. Power Switch/Volume Control (AM/FM Stereo Radio)
- 6. Tone Control (AM/FM Stereo Radio)
- 7. Preset Tuning Buttons (AM/FM Stereo Radio)
- 8. Band Select Switch (AM/FM Stereo Radio)
- 9. DX/LO Switch (AM/FM Stereo Radio)
- 10. Memory/Adjusting Button (AM/FM Stereo Radio)
- 11. Manual Tuning/Time Adjusting Switch (AM/FM Stereo Radio and Clock)
- 12. Frequency Readout Button (AM/FM Stereo Radio)
- 13. Power Switch/Volume Control (CB Radio)
- 14. Squelch Control (CB Radio)
- 15. Power Switch/Volume Control (Intercom)
- 16. Speaker Select Switch/Muting Level Control (Intercom)

Cassette Player:

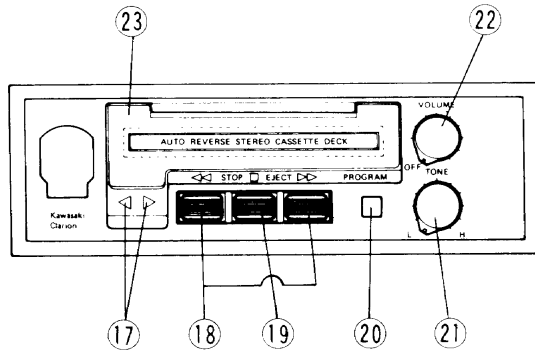

- 17. Program Indicators
- 18. F.F./Rew. Buttons
- 19. Stop/Eject Button
- 20. Program Change Button
- 21. Tone Control
- 22. Power Switch/Volume Control
- 23. Tape Slot Door

Other Switch and DIN Plugs:

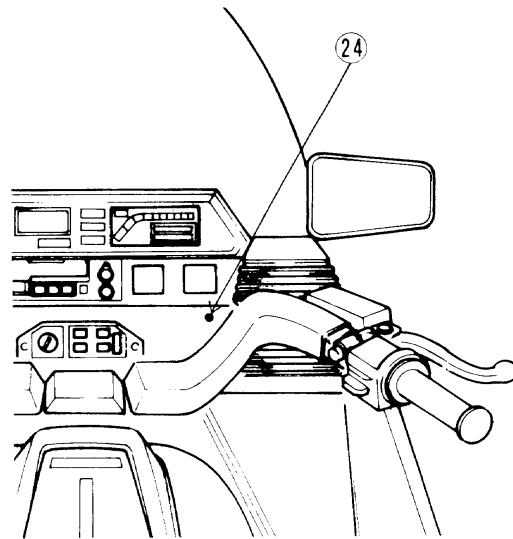

- 24. Speaker Switch for CB

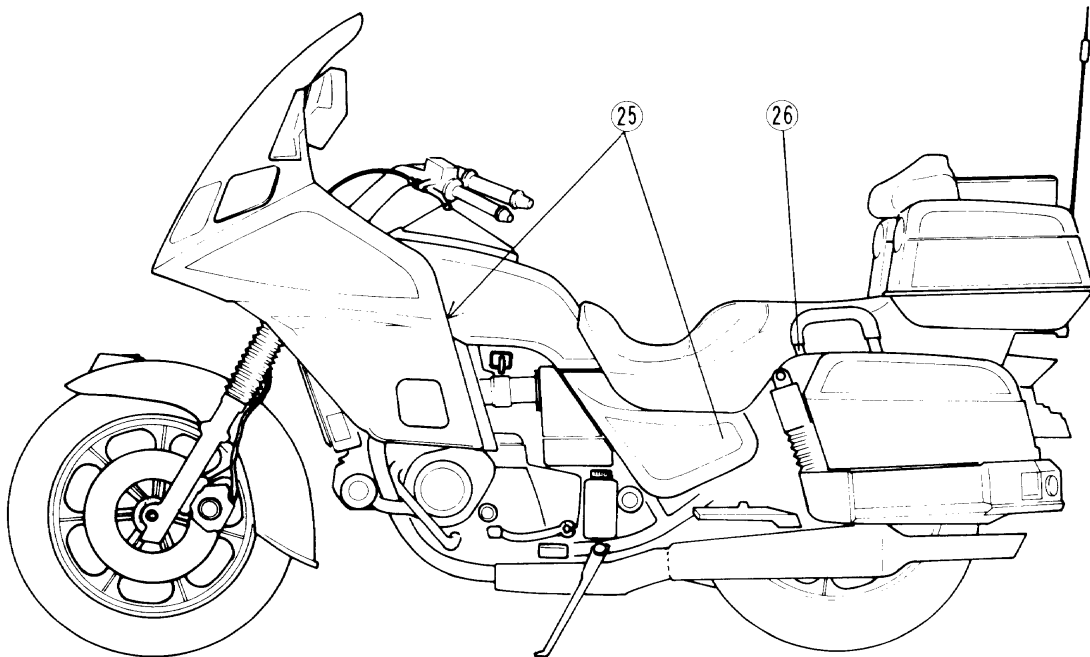

- 25. DIN Plugs
- 26. Passenger Talk Switch

AM/FM Stereo Radio and Cassette Player

Operating Procedures

- Turn off the power switches of the AM/FM stereo radio, cassette player, CB radio, and intercom.
- Rotate the squelch control and speaker select switch/muting level control counterclockwise all the way.
- Turn the ignition switch to the "ACC" or "ON" position.
- Rotate the power switch of the AM/FM stereo radio clockwise to turn on the radio. You will hear a click when the power comes on.

"NOTE"

○ The clock/radio frequency display will show the radio frequency for about 5 seconds after the power is turned on, and then will show the time.

- Select the band using the band select switch (AM or FM). At this time, the AM or FM indicator will appear on the clock/radio frequency display.

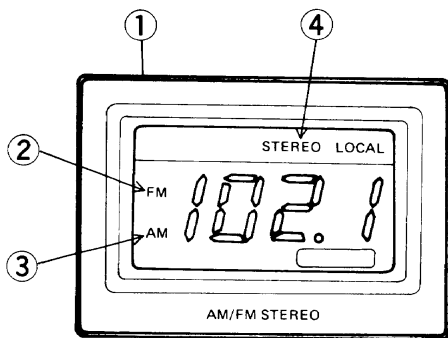

1. Clock/Radio Frequency Display
2. FM Indicator
3. AM Indicator
4. Stereo Indicator

- Turn in the desired station (auto seek tuning, preset tuning, or manual tuning). When a FM stereo signal is being received, the stereo indicator will appear on the display.
- Adjust the volume and tone controls of the radio.
- Rotate the power switch of the cassette player clockwise to turn on the player. You will hear a click when the power comes on.

- Open the tape slot door, and insert a cassette into the tape slot with the exposed tape side facing the slot. At this time, the radio program fades away and, instead, play of the tape will automatically start.
- Close the tape slot door, and select the program using the program change button.

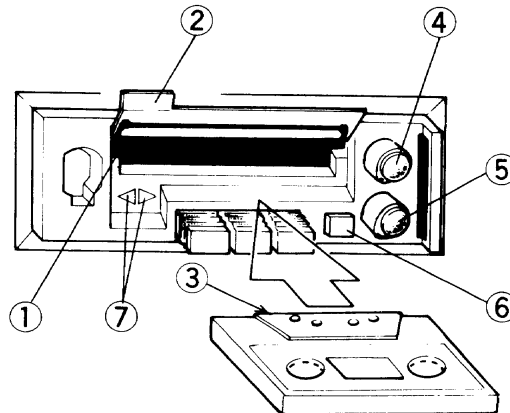

1. Tape Slot
2. Tape Slot Door
3. Exposed Tape Side
4. Power Switch/Volume Control
5. Tone Control
6. Program Change Button
7. Program Indicators

- Adjust the volume and tone controls of the cassette player.
- If you want to listen to the AM/FM stereo radio again, remove the cassette from the player and/or turn off the power switch of the player. As soon as the cassette player is turned off, you will hear the radio again.

CB Radio and Intercom

Operating Procedures

- Turn off the power switches of the AM/FM stereo radio, cassette player, CB radio, and intercom.

- Rotate the squelch control and speaker select switch/muting level control counterclockwise all the way.
- Turn the ignition switch to the "ACC" or "ON" position.
- Rotate the power switch of the CB radio clockwise to turn on the CB radio. You will hear a click when the power comes on. At this time, the CB and channel indicators will appear on the CB display.

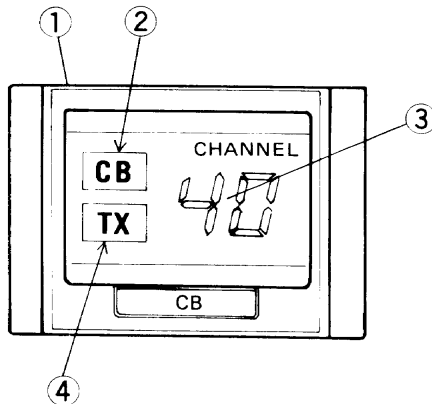

1. CB Display
2. CB Indicator
3. Channel Indicator
4. TX Indicator

- Set the speaker switch for CB to listen from ① both the fairing-mounted speakers and the "Ground Control" helmet sound system or from ② the "Ground Control" helmet sound system alone.
- Set the channel using the channel select switch.
- Turn the volume control of the CB radio clockwise a little. At this time, receiving signals or noise will be heard.
- Turn the squelch control clockwise until the noise is eliminated.
- Adjust the volume control of the CB radio to the desired sound level.
- With the rider talk switch and/or passenger talk switch turned on, transmit messages to the opposite CB station. At this time, the TX indicator will appear on the display. Release both talk switches to activate the receiver.
- Rotate the power switch of the intercom clockwise to turn on the intercom. You will hear a click when the power comes on.
- Adjust the intercom volume to the desired sound level while communicating with the passenger. Both the rider and passenger can communicate through the "Ground Control" helmet sound system and operate the CB radio.

AM/FM Stereo Radio, Cassette Player and Intercom

Operating Procedures

- Perform the procedures described in the "AM/FM Stereo Radio and Cassette Player" section.
- Rotate the speaker select switch of the intercom fully counterclockwise.
- Rotate the power switch of the intercom clockwise to turn on the intercom. You will hear a click when the power comes on.
- Adjust the intercom volume to the desired sound level while communicating with the passenger. Both the rider and passenger can communicate through the "Ground Control" helmet sound system and can listen to the AM/FM stereo radio or cassette player through the fairing-mounted speakers.
- If you want to listen to the radio or cassette player through the "Ground Control" helmet sound system, rotate the speaker select switch of the intercom clockwise until a click is heard. Now, communication between the rider and passenger are mixed with the radio or cassette sound.
- Turn the muting level control clockwise so that the radio or cassette player is muted by normal speaking but is not muted by ambient noise. With these settings, you can listen to the radio or cassette player while communicating through the "Ground Control" helmet sound system.

"NOTE"

- When the AM/FM stereo radio or cassette player is muted by ambient noise, turn the muting level control counterclockwise and/or decrease the intercom volume.

AM/FM Stereo Radio, Cassette Player, Intercom and CB Radio

Operating Procedures

- Perform the procedures described in the "AM/FM Stereo Radio, Cassette Player and Intercom" section.
- Rotate the power switch of the CB radio clockwise to turn on the CB radio. You will hear a click when the power comes on. At this time, the CB and channel indicators will appear on the CB display.

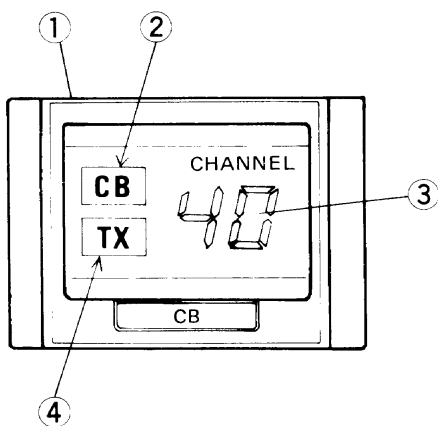

1. CB Display
2. CB Indicator
3. Channel Indicator
4. TX Indicator

- Set the speaker switch for CB to listen from
 - ① both the fairing-mounted speakers and the "Ground Control" helmet sound system or from
 - ② the "Ground Control" helmet sound system alone.
- Set the channel using the channel select switch.
- Turn the volume control of the CB radio clockwise a little. At this time, receiving signals or noise will be heard.
- Turn the squelch control clockwise until the noise is eliminated. You will be able to receive the CB signals through the speakers selected using the speaker switch for CB, and you will be able to hear the AM/FM stereo radio or cassette player through the speakers selected using the speaker select switch of the intercom. And also, you can communicate through the "Ground Control" helmet sound system.
- Adjust the volume control of the CB radio to the desired sound level.
- With the rider talk switch and/or passenger talk switches turned on, transmit messages. At this time, the TX indicator will appear on the display. Release both talk switches to activate the receiver.

"NOTE"

- The AM/FM stereo radio or cassette player will be muted under the following conditions:
 - ☆ While the rider and passenger are communicating on the intercom.
 - ☆ While either talk switch (rider or passenger) is turned on to transmit on the CB radio.
 - ☆ While CB signals are being received.

MAINTENANCE

Cleaning the Motorcycle

Preparation for cleaning

- Remove the control unit from the motorcycle and install the lid. Refer to Theft Prevention in the GENERAL INSTRUCTIONS chapter.

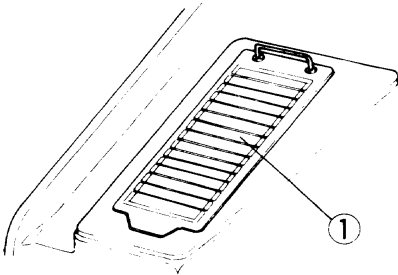

1. Lid

- Cover the cassette player with the anti-theft cover. Refer to Theft Prevention in the GENERAL INSTRUCTIONS chapter.

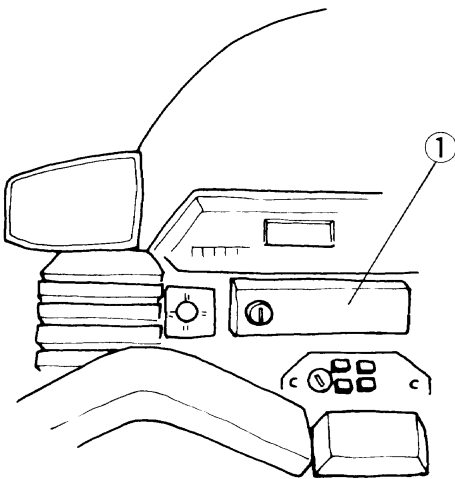

1. Anti-Theft Cover

Cleaning Note



- Avoid spraying water with great force near the audio systems.

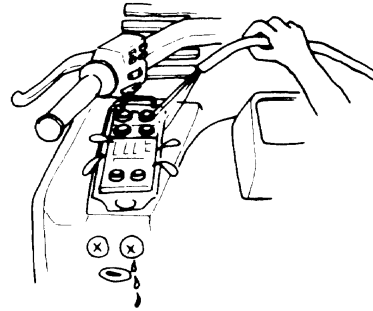

- To prevent surface damage, do not clean plastic parts with organic solutions such as gasoline, thinner, or benzine. Use a soft cloth which has been soaked in a solution of neutral detergent to clean plastic parts, then dry them with a soft cloth.

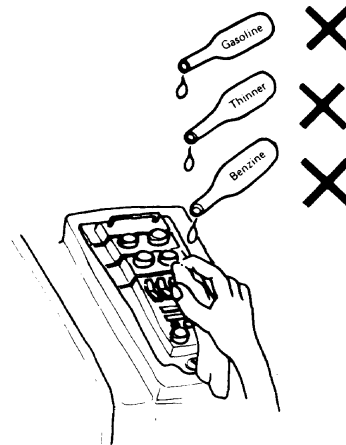

Cassette Player

Cleaning

After the player is used for a long time, tape residue and dust tend to build up on the head and tape path. A dirty head will reduce the overall efficiency of the head, and poor or distorted sound may occur. Also, a dirty pinch roller or capstan could cause erratic tape movement or jamming. To prevent these problems and insure longer life for your cassette player and tapes, clean the head, pinch rollers and capstans from time to time with a cotton swab slightly moistened with alcohol.



**Technical
Training**

**Component Layout,
Function, and Identification**

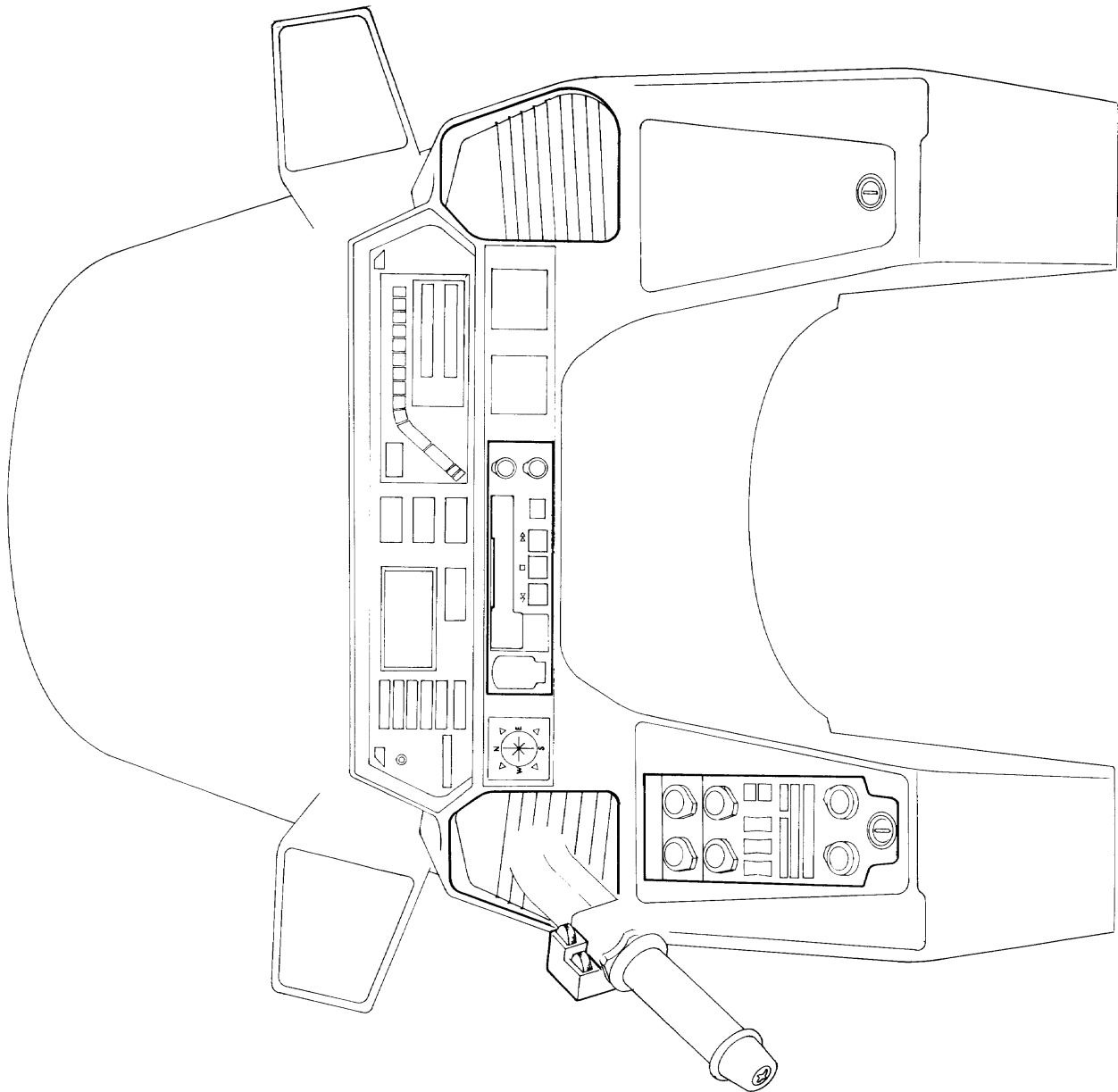

Component Layout

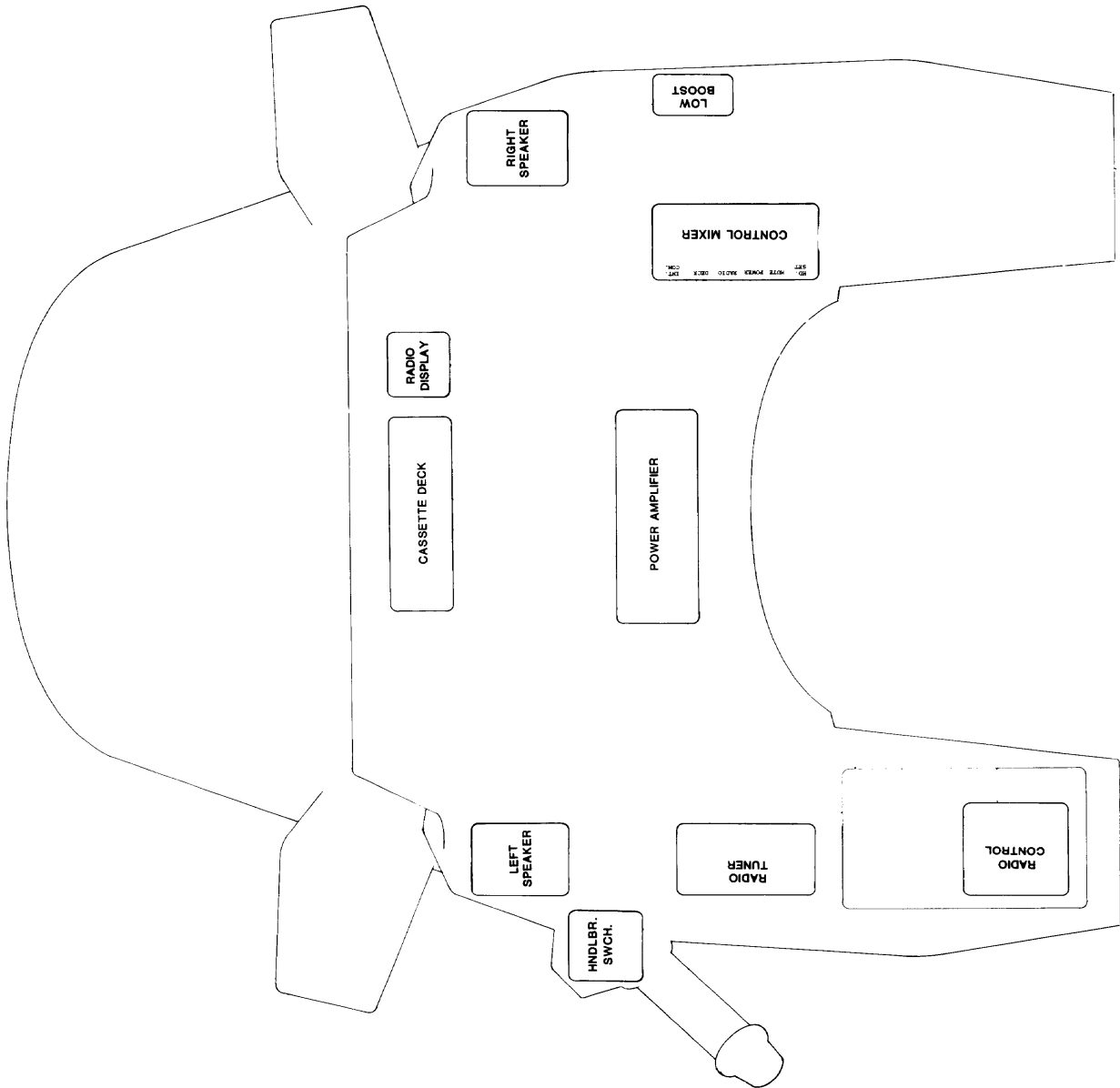

Component Function

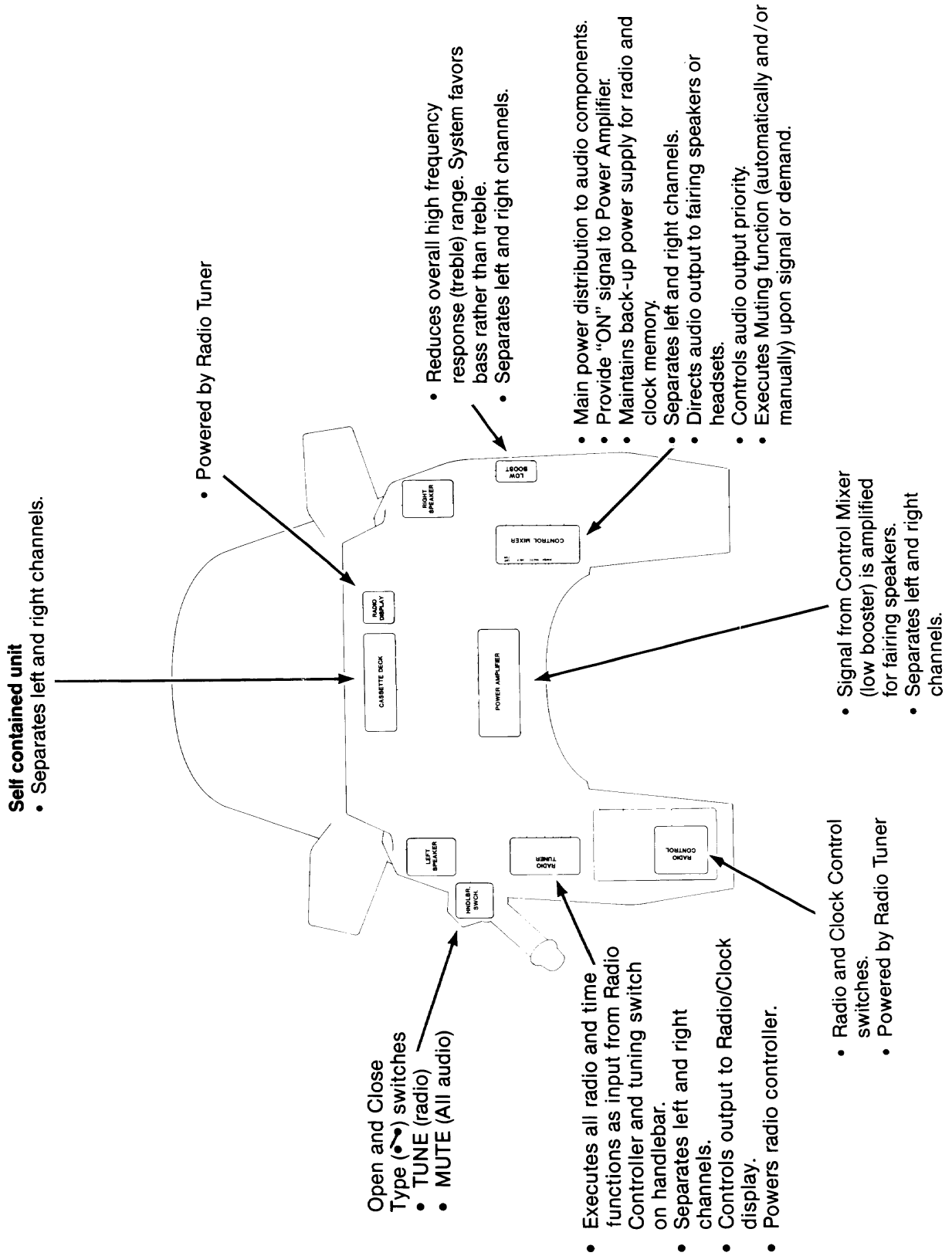

Component Identification

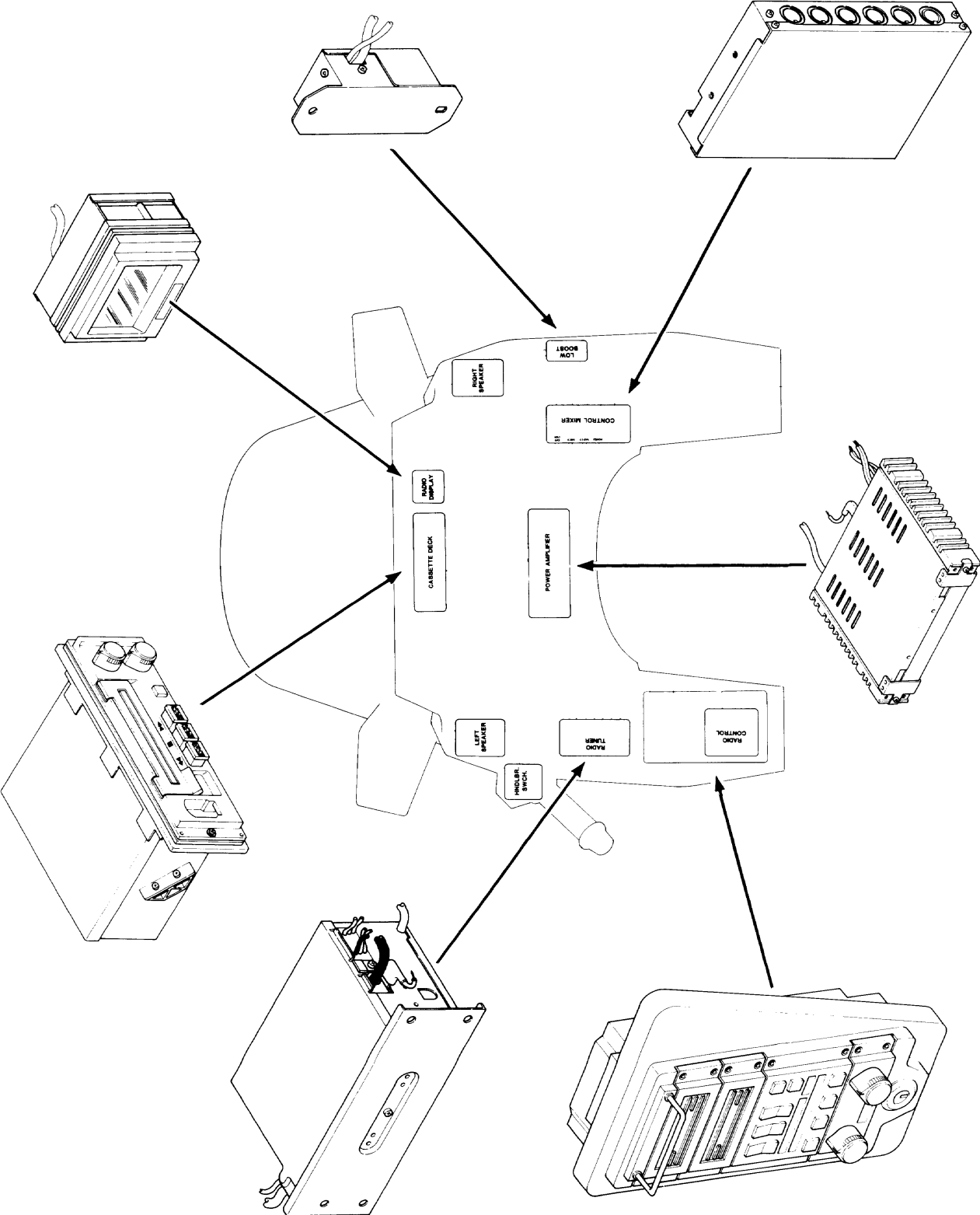



- **You and your customer must understand normal reception characteristics and limitations. Remember, radio signals and reception can be affected by atmospheric conditions, strength of radio station signals, physical location of the motorcycle, electrical accessories on the motorcycle, etc.**
- **Complete Checklist**
- **Check that the battery is fully charged.**
- **Always use the recommended resistor spark plugs to decrease static.**
- **Check that the antenna is not grounded if all radio (AM, FM and CB) reception is poor.**
- **Check all connectors. They must be tight, clean, and dry.**

Quick Fuse Failure Analysis

No.	Fuse	System Conditions When Failed	No.	Fuse	System Conditions When Failed	
1	4-amp. Black lead to power AMP	Speakers All Others	6	1-amp, Red lead Clock and Radio Memory	See NOTE Below	
2	1-amp, Blue lead to Control Mixer	Radio Display Light and Intercom All Others				
3	2-amp, Blue lead to Cassette	Cassette All Others				
4	3-amp, Blue lead to CB	CB (all) All Others	7	2-amp, Blue lead to Radio Tuner	Radio Intercom	No OK
5	1-amp, Red lead to CB	CBTX Scan			CB Cassette	OK OK

NOTE: If Fuse No. 6 fails (or the battery is disconnected), the Clock and Radio memories are erased. Note the customer's preset radio stations before disconnecting power. When power is restored, input the customer's presets and set the correct time.

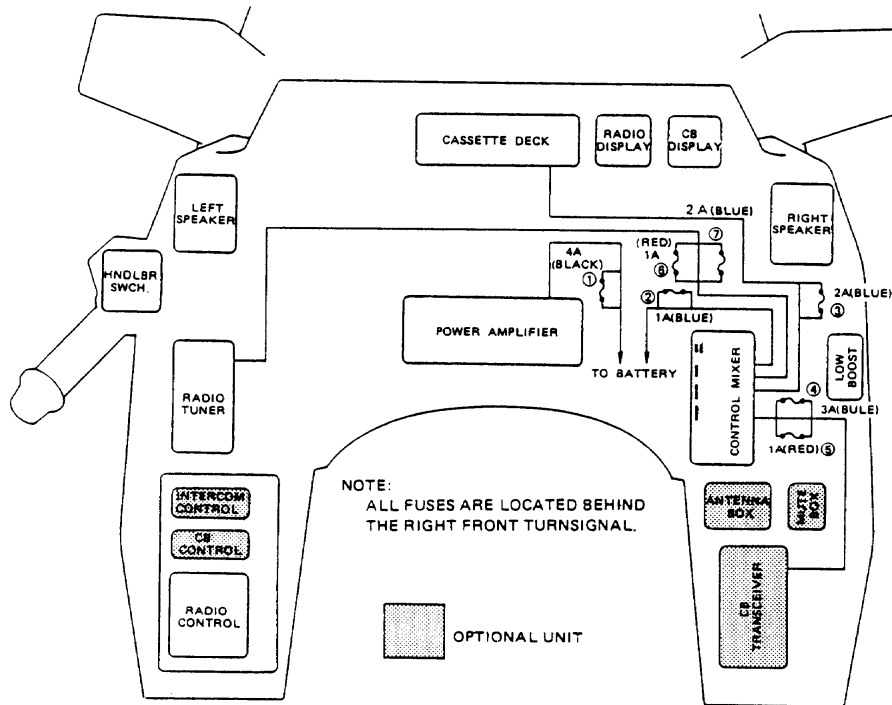

Audio System Checklist

Before moving on to the individual troubleshooting flow charts and test procedures in this chapter, take a few minutes to check the operation of the entire audio system. Since the functions of many components are interrelated, there may be other problems not reported by your customer. Knowing the whole picture will simplify your job by ensuring that you start troubleshooting with the proper flow charts and test procedures.

Be sure to complete this checklist before calling the HOT LINE with any audio system problem. The HOT LINE staff will ask questions based on this checklist.

Make the operation checks as requested. If any malfunctions occur check the box to the right, then check the affected components, controls or features.

Operation Checks

1. Is radio reception normal?
AM FM CB
2. Do all audio systems produce sound?
AM/FM Radio Cassette Player
CB Transceiver Intercom
3. Does left channel function?
Headset Fairing Speaker
4. Does right channel function?
Headset Fairing Speaker
5. Does CB transceiver transmit normally?
6. Do left handlebar switches function?
TUNE MUTE
TALK ON-UP
7. Does passenger talk switch function?
8. Do AM/FM stereo radio/clock controls function?
Power/Volume Control Switch
TONE
MEMORY TUNING buttons
FM/AM switch DX/LO switch
UP/DN switch FREQ button
ADJ button

Malfunctions?

9. Do CB controls function?
Power/Volume Control Switch
Squelch
10. Do intercom controls function?
Power/Volume Control Switch
SP/MUTE switch
11. Does clock/radio frequency display function?
a.m. p.m. STEREO
LOCAL AM FM
MEMORY Time
Radio Frequency
12. Does CB display function?
CB TX
Channel
13. Does speaker switch for CB function?
14. Do cassette player controls function?
Power/Volume Control Switch
TONE
PROGRAM change button
Program Indicators
STOP/EJECT button
F.F./Rew. Buttons

RADIO CHARACTERISTICS

Motorcycle radio receivers are more sophisticated than other receivers, so it will be beneficial to assist the consumer in understanding wave propagation. Radios can be divided into AM (Amplitude Modulation) and FM (Frequency Modulation). Radio signals and reception are affected by certain factors, including atmospheric conditions, strength of radio station signals, physical location of motorcycle electrical accessories on motorcycle, etc. Understanding these limitations, will help you minimize these conditions.



MOTORCYCLE RADIO vs. HOME STEREO

The radio in a moving vehicle has more difficulty with reception, especially with FM, than a home receiver with a fixed antenna, often located high on the roof. Not only is the motorcycle's antenna relatively short and a compromise in design between the best for AM and FM, but the incoming signal is subject to changes in direction, strength and interference conditions as the vehicle moves. Three kinds of problems are most often encountered in moving vehicles. They are strong signal interference, skip noise (due to weak signal) and multipath noise.

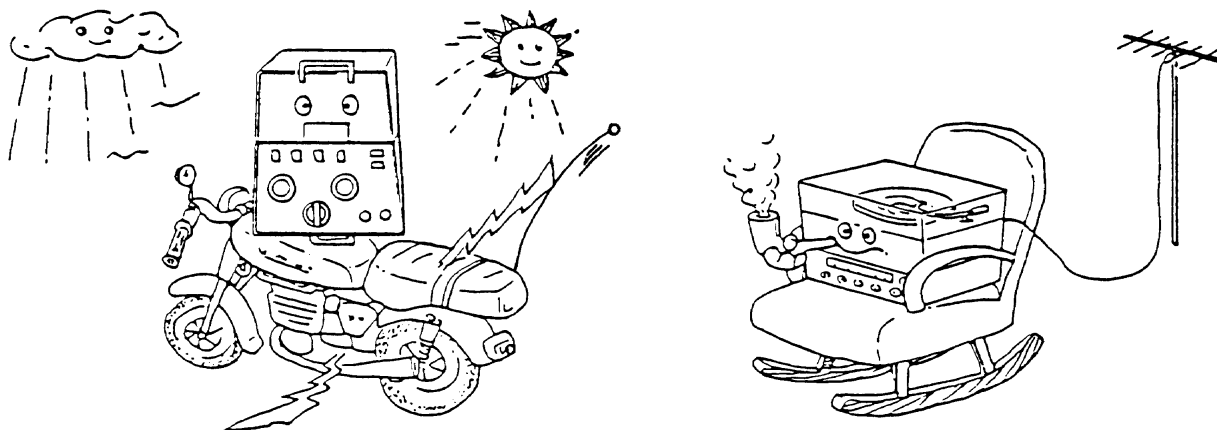

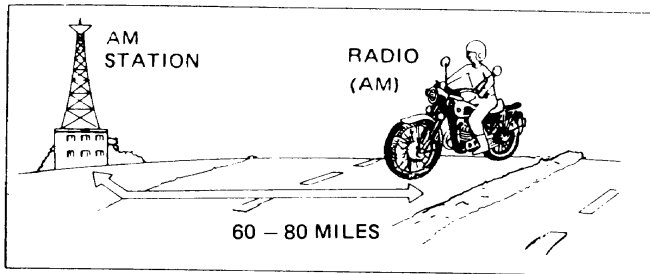

SERVICE AREA

Beyond a distance of 60 to 80 miles from an AM station, the station signal weakens. This causes station mixing and interference on the radio.

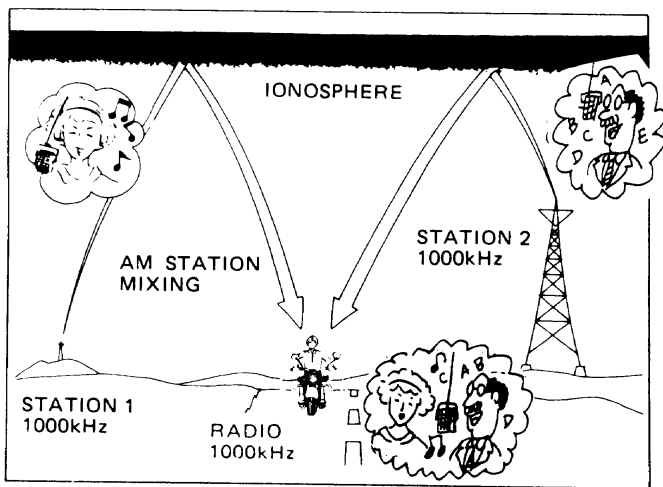

STATION MIXING

AM waves bend around objects such as buildings or mountains, and bounce off the ionosphere. Because of this, two stations might be picked up on the same frequency at night. This is called Station Mixing.

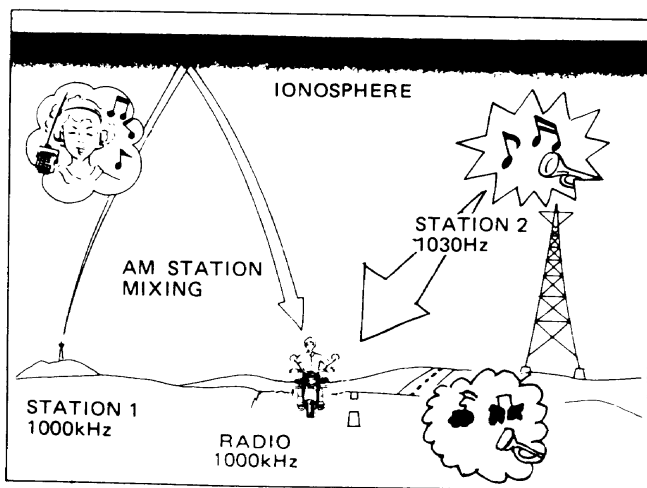

INTERFERENCE

When an adjacent station has a very strong signal, annoying noises may occur while receiving a weaker station. In the worst cases, the adjacent station may interfere. **THIS IS NOT RECEIVER TROUBLE.** This is caused by particular wave conditions.

Since stereo FM is a two channel system it has a fuller sound than monaural FM, and a more complex signal. This means the reception range of stereo FM is usually shorter, and reception problems are more apt to occur.

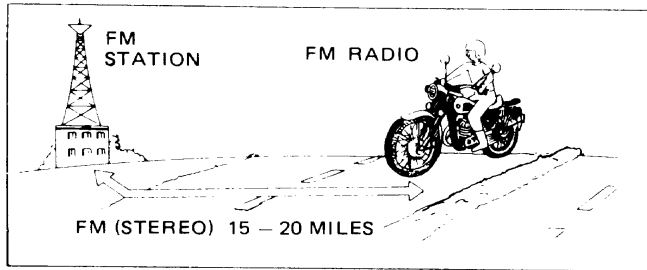

SERVICE AREA

Beyond a distance of 15 to 20 miles FM stations may fade out completely or fade in and out. When driving in weak signal areas, such as hills, valleys, tunnels, etc., unusual noise interference may occur.

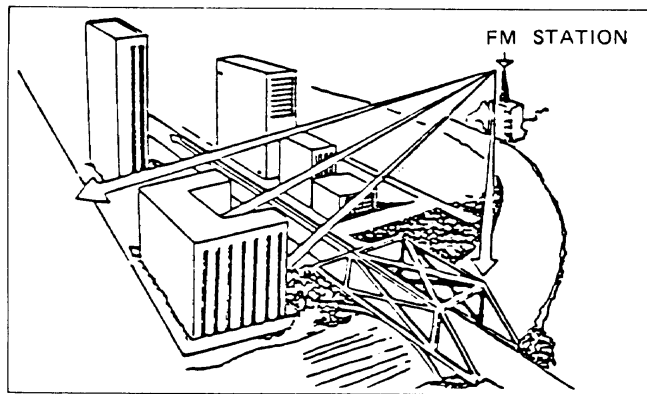

STATION FLUTTER

FM signals are easily reflected by solid objects. Therefore FM signals are blocked by tall buildings or other obstructions. This is called a flutter area, and results in POPS AND HISSES in the radio.

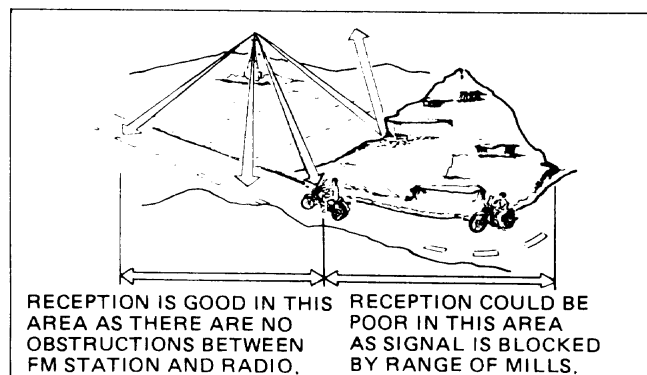

FADING

Since FM signals are easily reflected by solid objects, it is possible for an area to be blocked from the FM station. Fading occurs when an object blocks the path between the FM station and radio.

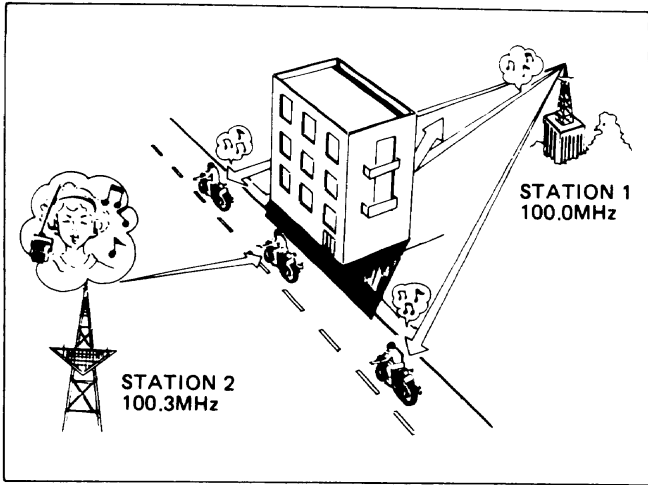

STATION JUMPING (STATION SWAPPING)

FM has a special characteristic called station jumping. This occurs when the frequency of two stations are near each other and a tall building temporarily blocks the desired signals. The Automatic Frequency Control in the radio tunes to the adjacent station until the desired signal returns.

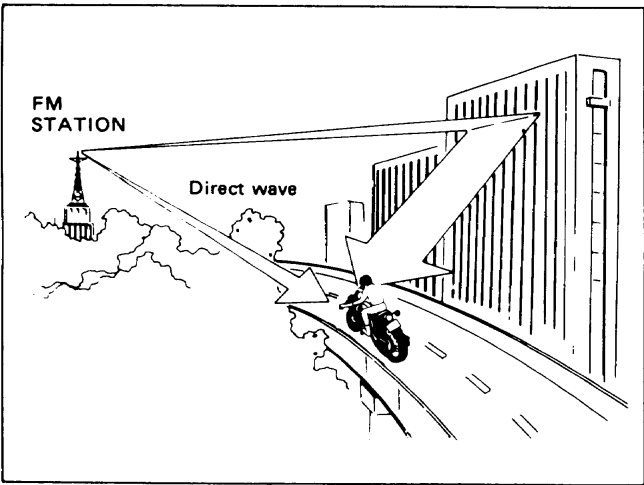

MULTIPATH

Because of the reflecting characteristics of FM signals, like light, direct and reflected signals may reach the motorcycle antenna at the same time, which is called "The multipath effect". Sometimes the direct and reflected signals cancel each other out, causing dead spots. As the motorcycle moves through these spots, the listener will hear a fluctuation of sound. These are the same characteristics as so called "Ghost" images on a TV screen when reflection of TV waves occur.

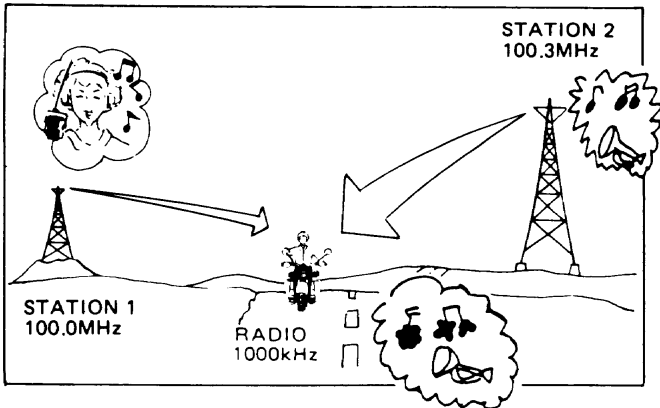

INTERFERENCE

When an adjacent station has a very strong signal, annoying noises may occur while receiving a weaker station. In the worst cases, the adjacent station may interfere.

SASC FEATURE

The Kawasaki motorcycle radio has a signal actuated stereo control (SASC) feature. When listening to a stereo station and the station signal becomes weak, you will get static and interference. If this should happen, the SASC will automatically switch from stereo to monaural, thereby eliminating or reducing the static and interference. When the station signal becomes stronger, the SASC will automatically switch from monaural back to stereo. When the SASC switches back and forth from stereo to monaural, the stereo light on the radio will go on and off accordingly. This is not a malfunction, but is an indication that the SASC is functioning properly, as it was designed to do. The SASC circuit extends the listenable service range by about 20%.

SUPER SASC FEATURE

SUPER SASC is the latest circuit developed by Clarion to reduce annoying multipath distortion in addition to the SASC which improves weak signal reception. SUPER SASC continuously monitors "multipath distortion" and eliminates unacceptable noise automatically by reducing high frequency response.

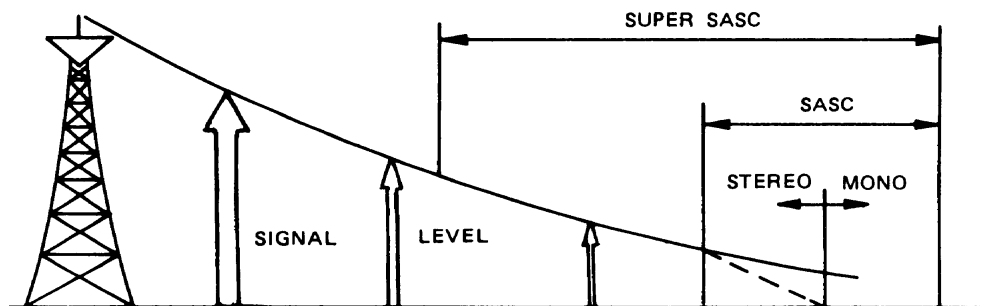

CB Performance

A variety of factors combine to determine motorcycle CB radio performance :

- Environmental conditions (buildings, mountain, electrical interference, traffic).
- Atmospheric conditions (weather, humidity, skip conditions).
- System output (4 watts max—limited by Federal regulations).
- Directional characteristics of the installation (the Kawasaki/Clarion system transmits and receives best in forward direction).
- Accuracy of adjustments (Standing Wave Ratio and Field Strength).

When evaluating CB performance, it is common practice to compare the maximum communication ranges of two or more vehicles. Such comparisons are valid only when the CB's are operated at the same time and place.

Since environmental and atmospheric conditions are constantly changing, any other type of comparison is meaningless. A 1 to 2 mile communication range between CB-equipped motorcycles is typical. At times you will be able to transmit farther than 2 miles. And occasionally under poor conditions you may not be able to transmit a mile.

If a customer believes he is experiencing CB performance difficulties, first check that the CB unit is properly adjusted. Improper adjustment can cut communication distance in half. CB adjustment consist of tuning the antenna system for maximum FS (Field Strength) and minimum SWR (Standing Wave Ratio). An FS/SWR meter is required. This type of meter is commonly available at electronic supply stores such as Radio Shack for about \$20.00. The antenna box and the CB module are mounted under the fairing storage compartment.

CB adjustments must be performed outdoors, in an open area, away from any electrical interference.

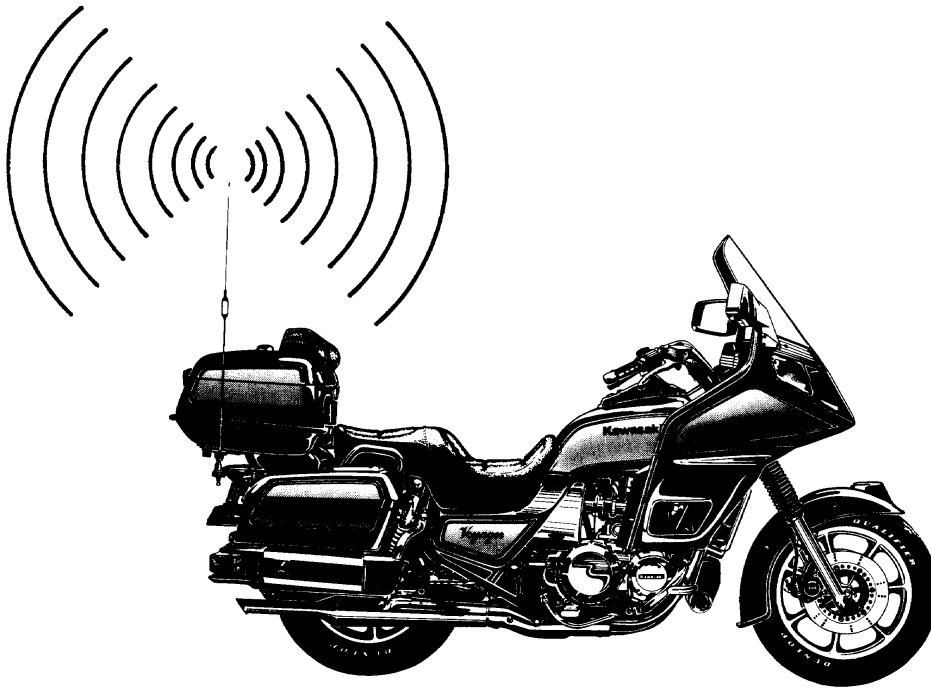

Antenna Trimming Procedure #1 Field Strength (Antenna Box)

NOTE: If a Field Strength meter is not available then trim the antenna box using an S.W.R. meter as described in the following Procedure #1A

- Set the FORWARD/REFLECTED switch to the FORWARD position
- Place the FS Tester on the fairing, inside the wind screen
- Turn the ignition switch to ACC
- Set the CB on CHANNEL 20
- Press the CB Talk Switch
- Adjust the calibration knob so that the needle is about mid scale.
- Using a non-metallic screwdriver, adjust the CB Antenna trimming screw on the Antenna Box
- Adjust the trimming screw for maximum FS
- Repeat this procedure after performing Antenna Trimming Procedure #2

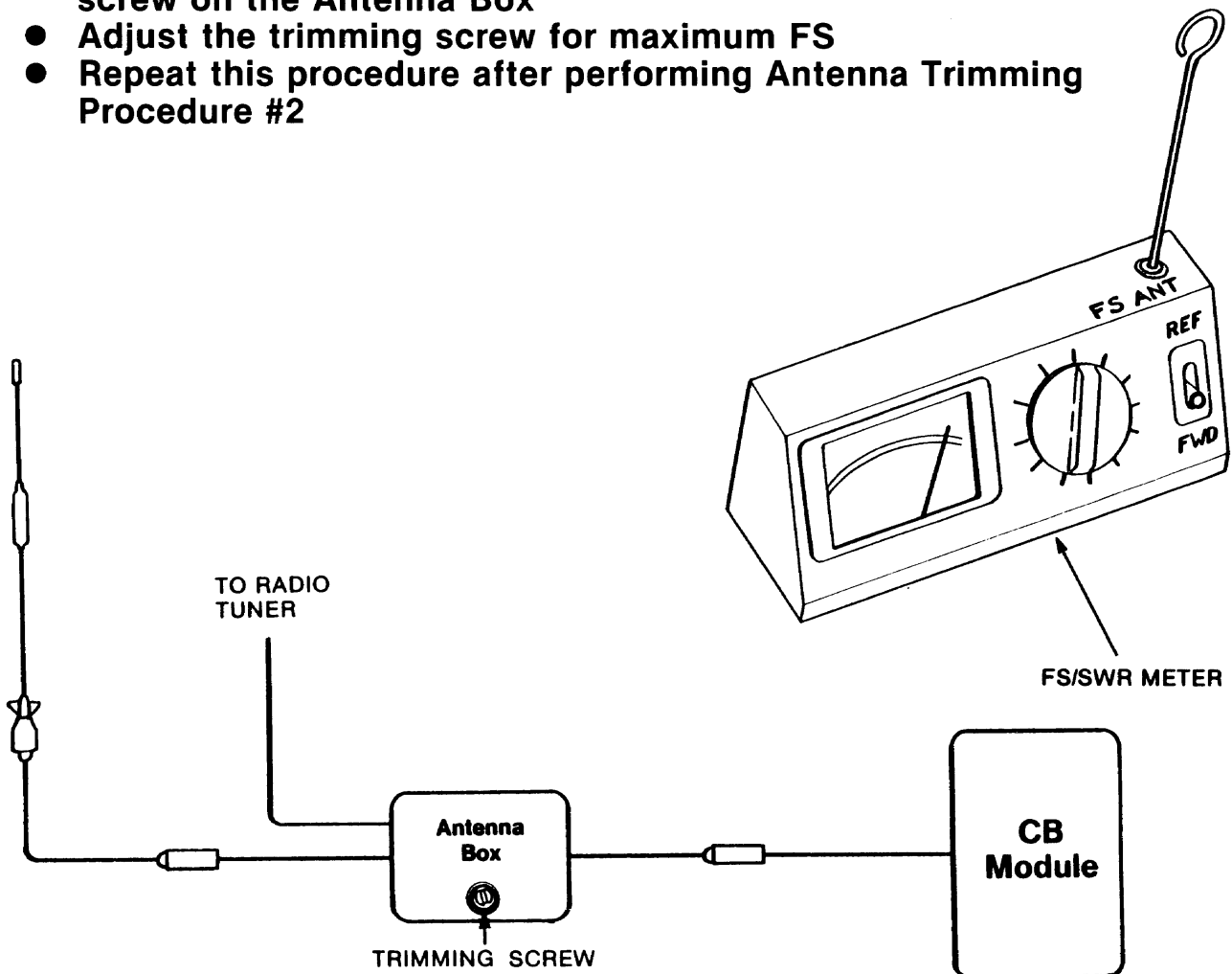

Antenna Trimming Procedure #1A Standing Wave Ratio (Antenna Box)

If a Field Strength meter is not available as described in Antenna Trimming Procedure #1, then use an S.W.R. meter as follows:

- Connect the meter as shown.
- Turn the key to ACC
- Set the FORWARD/REFLECTED switch on the meter to the FORWARD position.
- Set the CB on CHANNEL 20
- While holding down the CB TALK button, adjust the calibration knob so that the meter indicates CAL.
- Release the TALK button.
- Flip the FORWARD/REFLECTED switch to the REFLECTED position.
- Depress and hold the talk button and using a non-metallic screwdriver, adjust the trimming screw to obtain the LOWEST possible S.W.R.
- Repeat this procedure after performing Antenna Trimming Procedure #2.

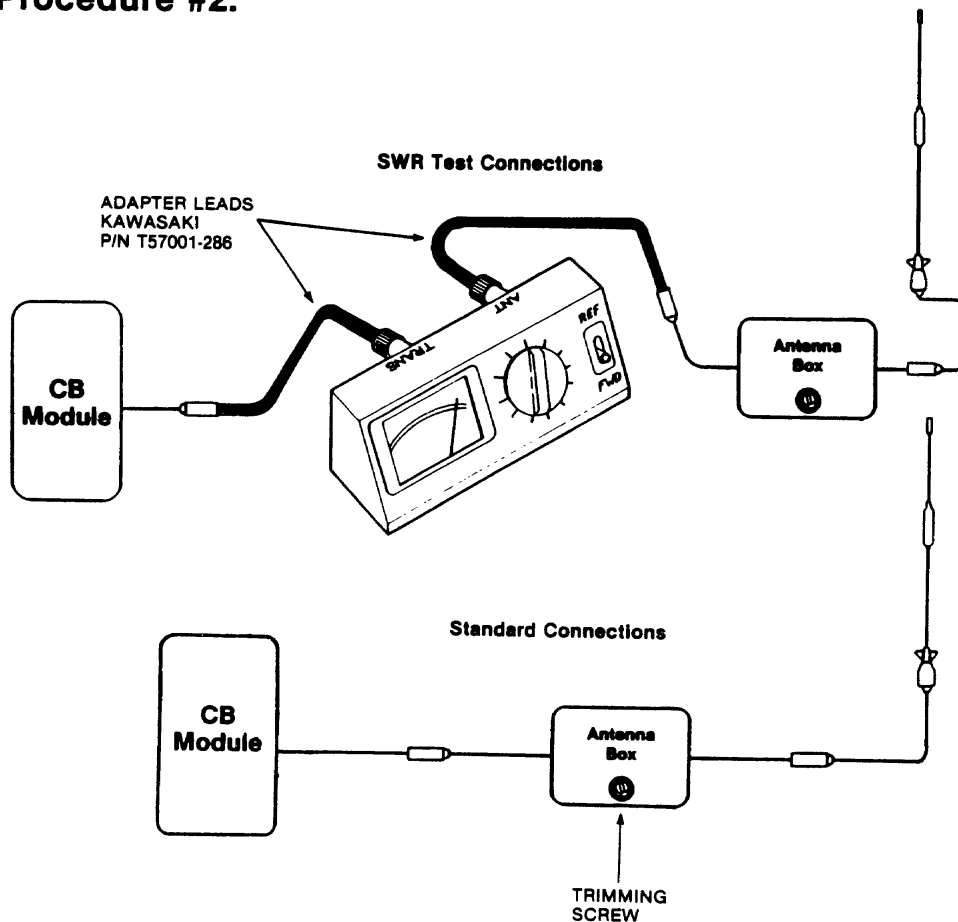

Antenna Trimming Procedure #2 Standing Wave Ratio (Antenna Length)

Test Connections

- Perform Antenna Trimming Procedure #1 or #1A first.
- Connect the SWR Tester as shown.
- Set the FORWARD/REFLECTED switch to the FORWARD position.
- Set the CB on CHANNEL 20.
- While holding down the CB TALK button, adjust the calibration knob so that the meter indicates CAL.
- Flip the FORWARD/REFLECTED switch to the REFLECTED position.
- Depress the talk button and read the SWR meter. If the Antenna is trimmed properly, the meter will indicate an SWR of 1.5 or less.
- If the SWR is higher than 1.5, cut the antenna as described in the following procedure #2A.
- Repeat Antenna Trimming Procedure #1 or #1A.

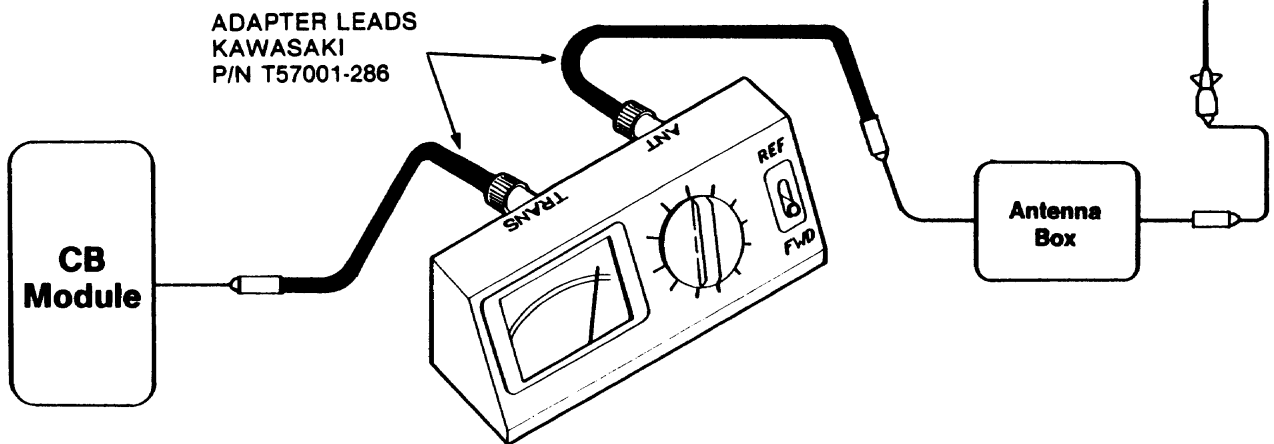

Standard Connections

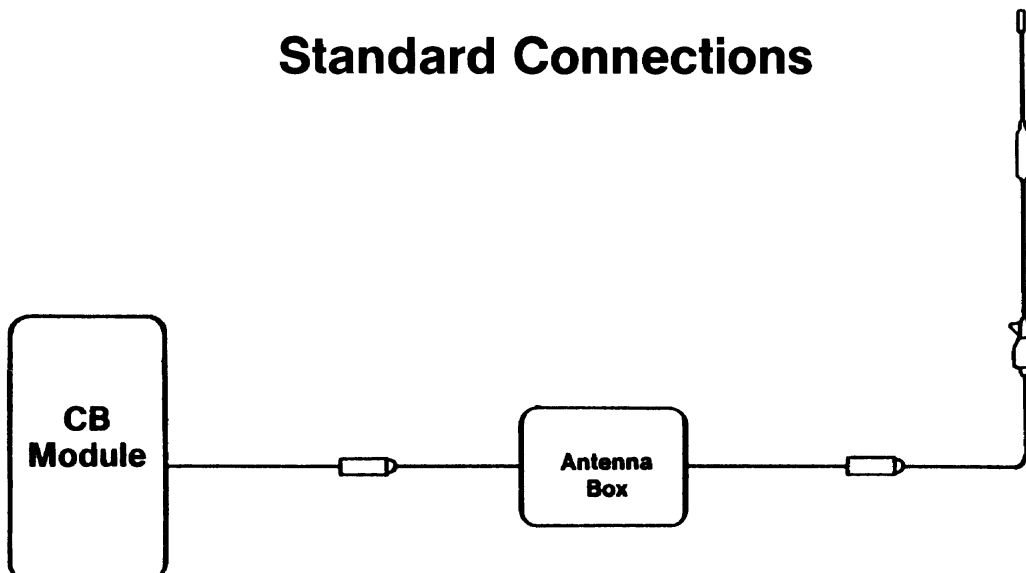

Antenna Trimming Procedure #2A (Antenna Length)

- Perform Antenna Trimming Procedure #2 first.
- Loosen the setscrew (see note below) and remove the antenna upper section from the aluminum housing.
- Cut 3 mm from the bottom of the antenna upper section.
- Reinstall the antenna upper section in the housing and repeat Antenna Trimming Procedure #2.
- Continue cutting 3 mm at a time from the antenna upper section and repeating procedure #2 until the SWR begins to increase.
- Raise the antenna upper section in the aluminum housing until the SWR drops again to the lowest meter reading, then tighten the setscrew.

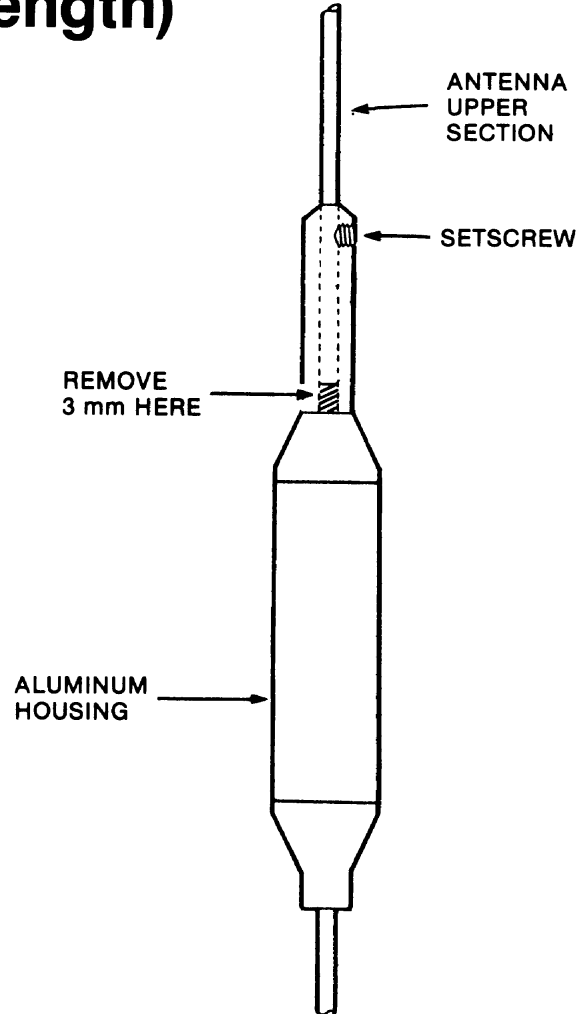

NOTE:

- If the antenna setscrew is difficult to remove, cut through the aluminum housing below the setscrew. *Do not* cut through the antenna itself (the piece remaining in the housing could be difficult to get out and you might not be able to obtain the lowest possible SWR because the antenna upper section may be too short).
- Remove the antenna upper section, then drill and tap the housing for a new setscrew.

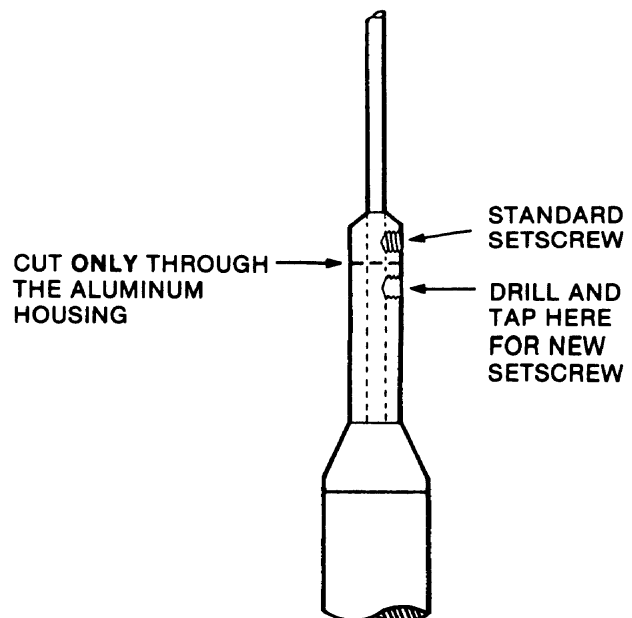

No Sound from Radio or Cassette (Both)

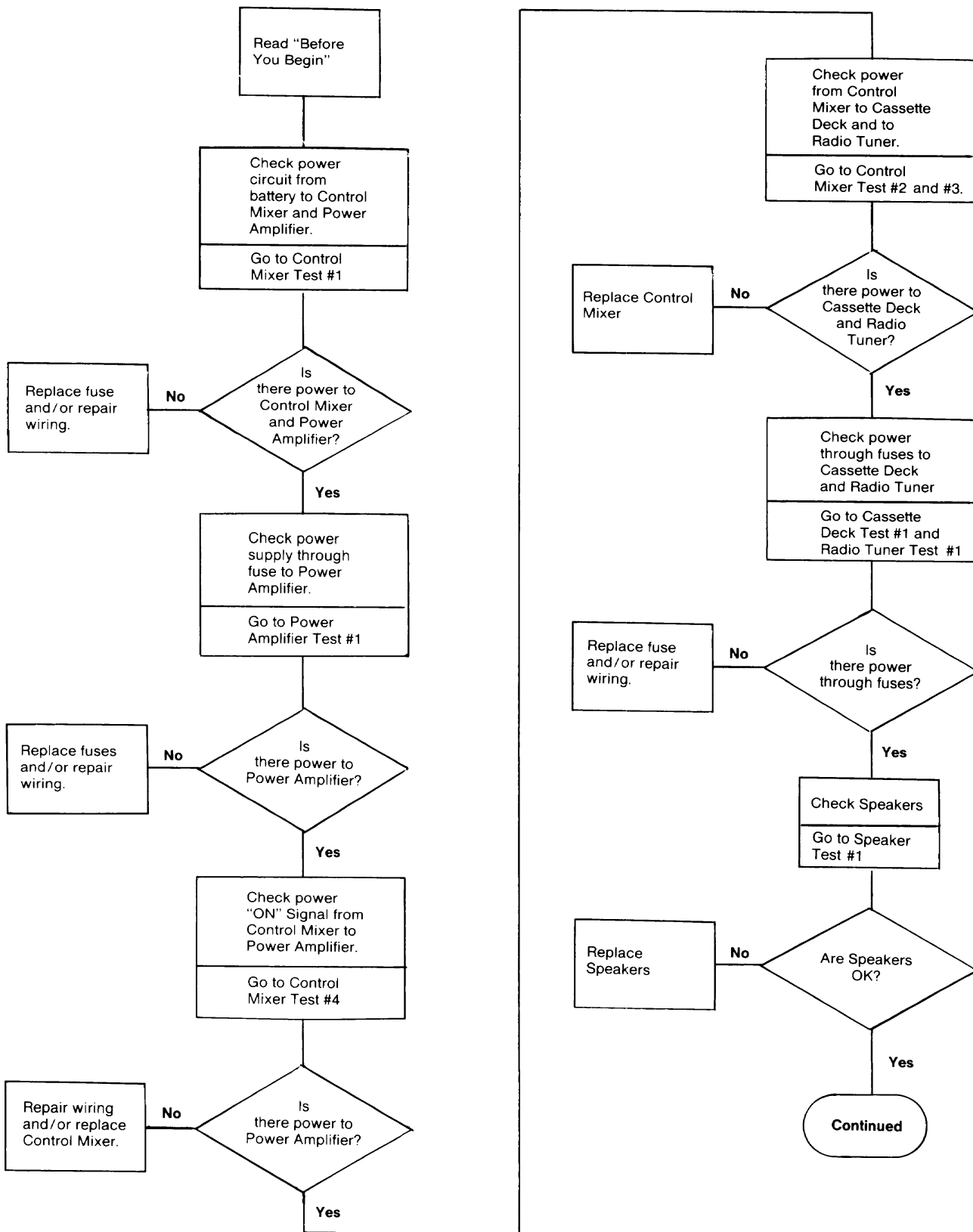

No Sound from Radio or Cassette (Both)

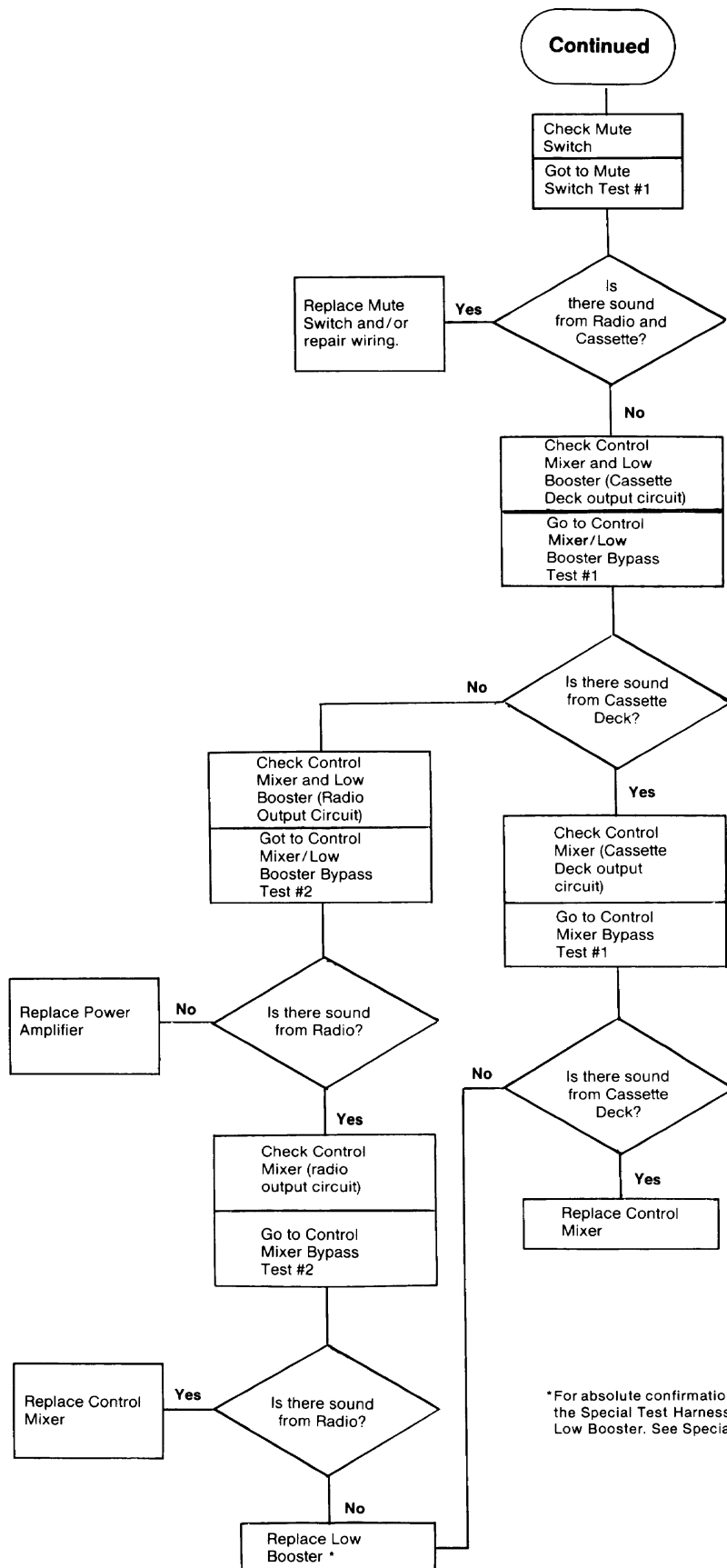

*For absolute confirmation of a defective low booster, the Special Test Harness can be used to bypass the Low Booster. See Special Test #1.

Control Mixer Test #1

Power Circuit From Battery To Control Mixer And Power Amplifier

- Turn key to ACC
- Meter should indicate 12 VDC

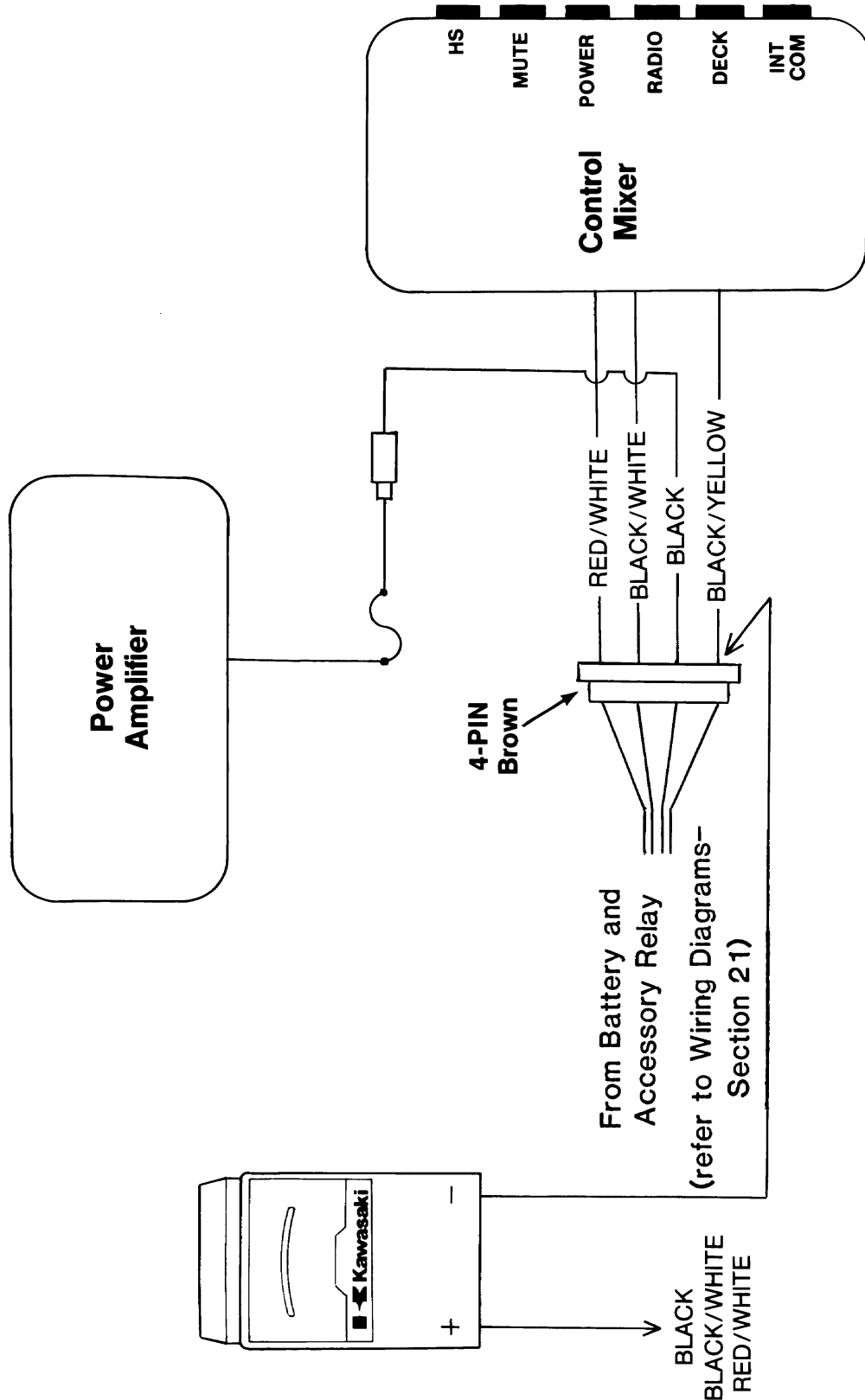

Power Amplifier Test #1

Power Through Fuse To Power Amp

- Turn key to ACC
- Meter should indicate 12 VDC

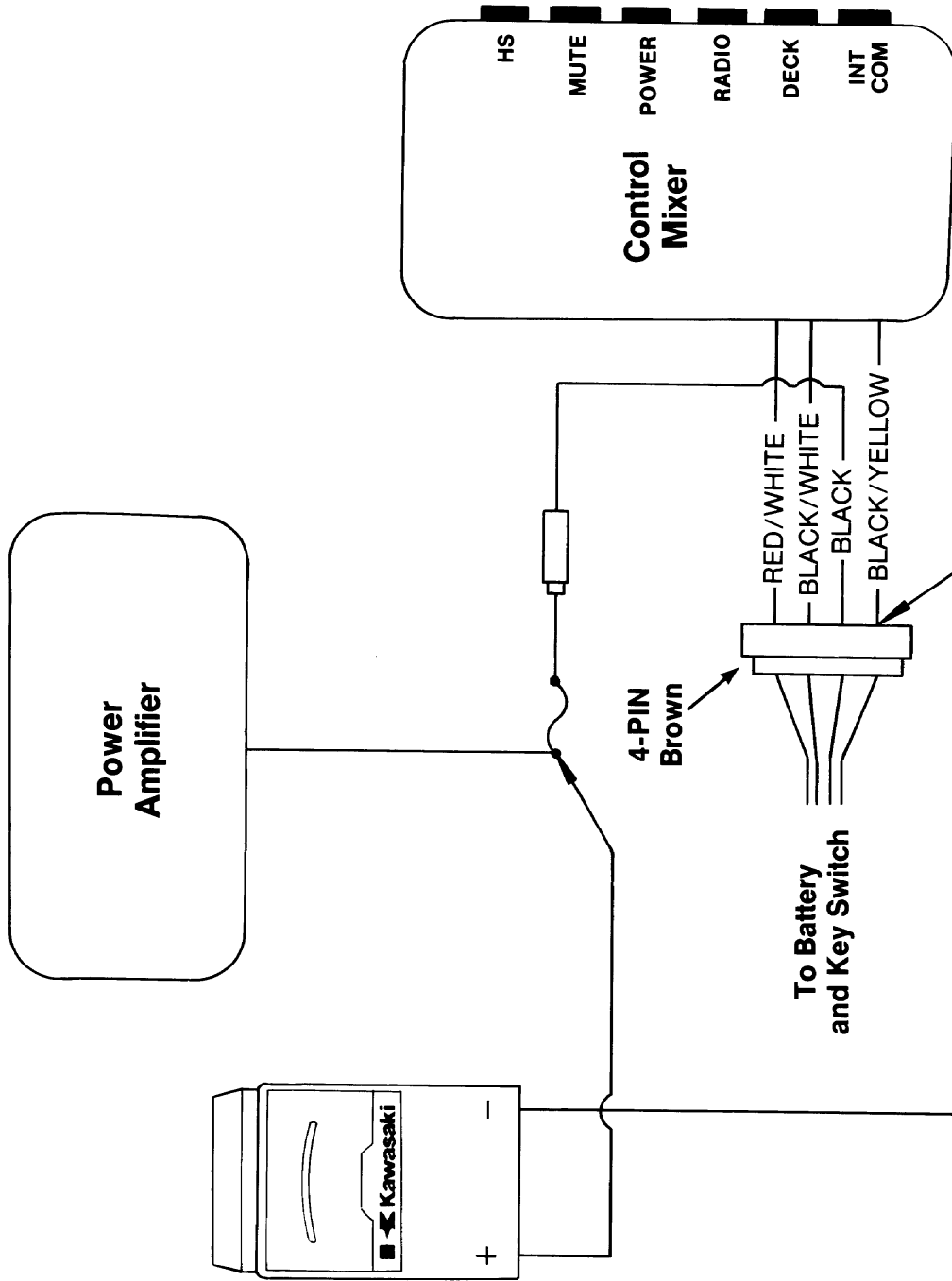

Control Mixer Test #4

Power "ON" Signal From Control Mixer To Power Amplifier

- Turn key to ACC
- Turn Radio ON or turn Cassette Deck ON and insert tape
- Meter should indicate 12 VDC

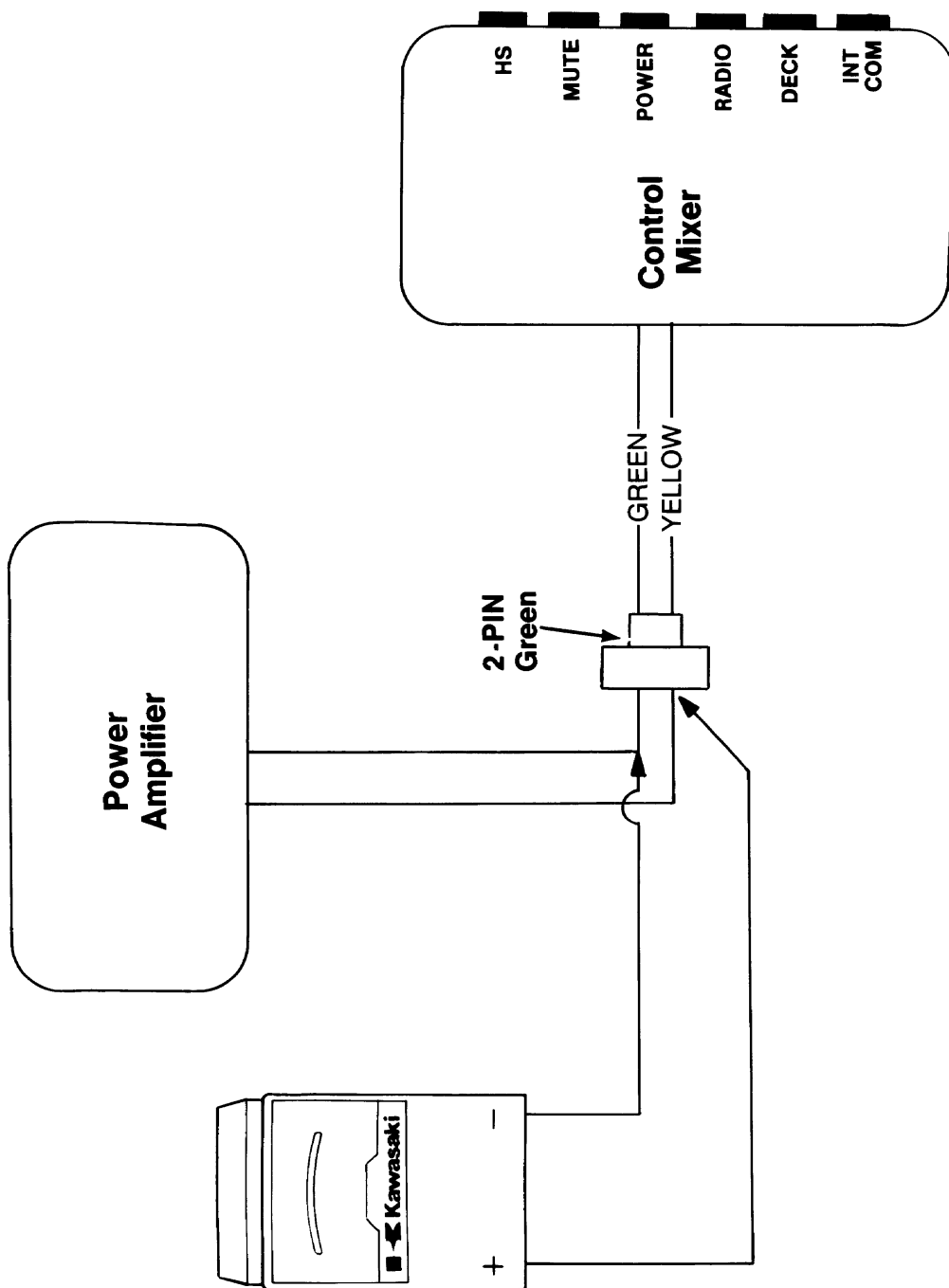

Control Mixer Test #2

Control Mixer Output To Cassette Deck

- Turn key to ACC
- Meter should indicate 12 VDC

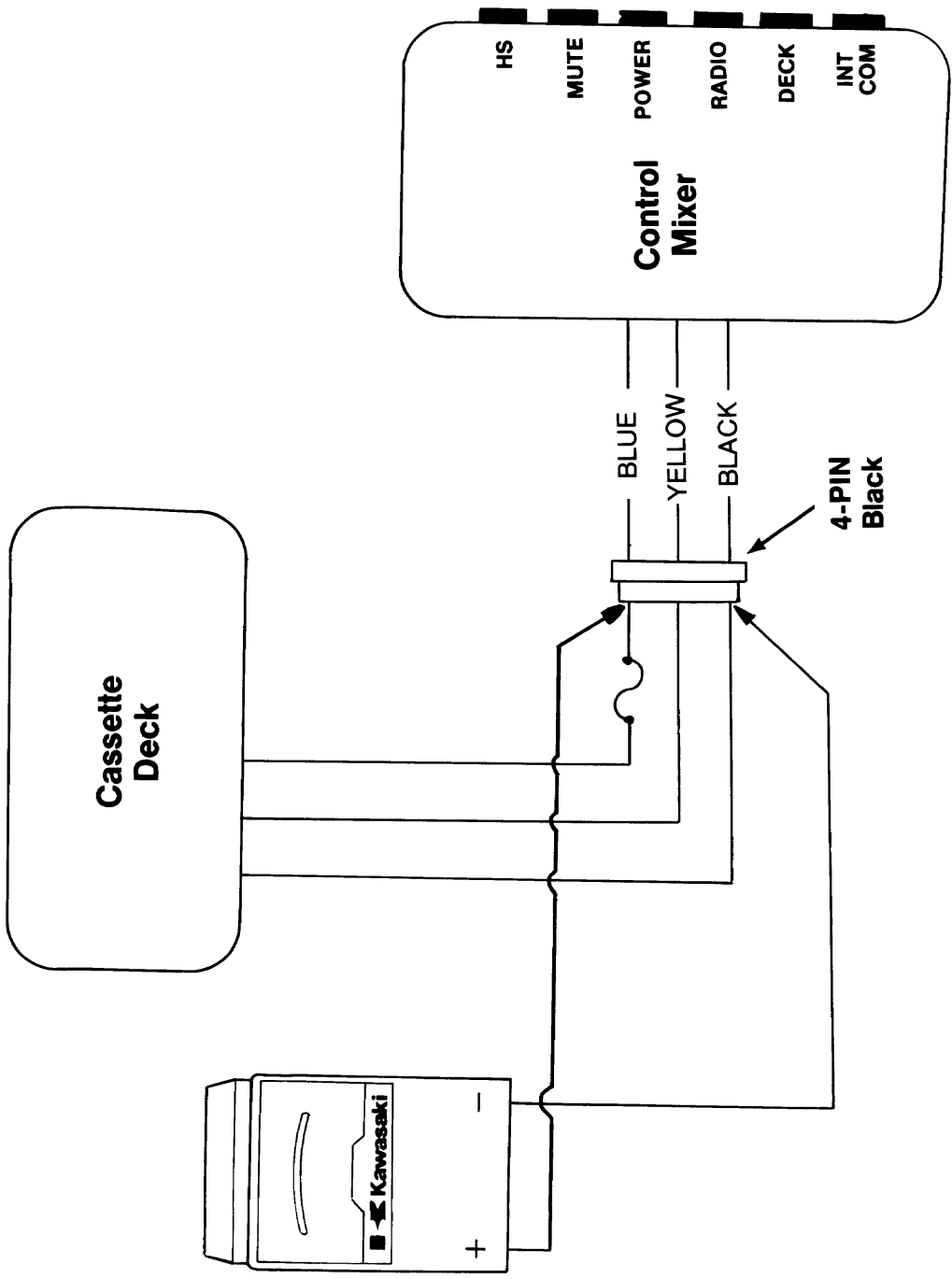

Control Mixer Test #3

Control Mixer Output To Radio Tuner

- Turn key to ACC
- Meter should indicate 12 VDC

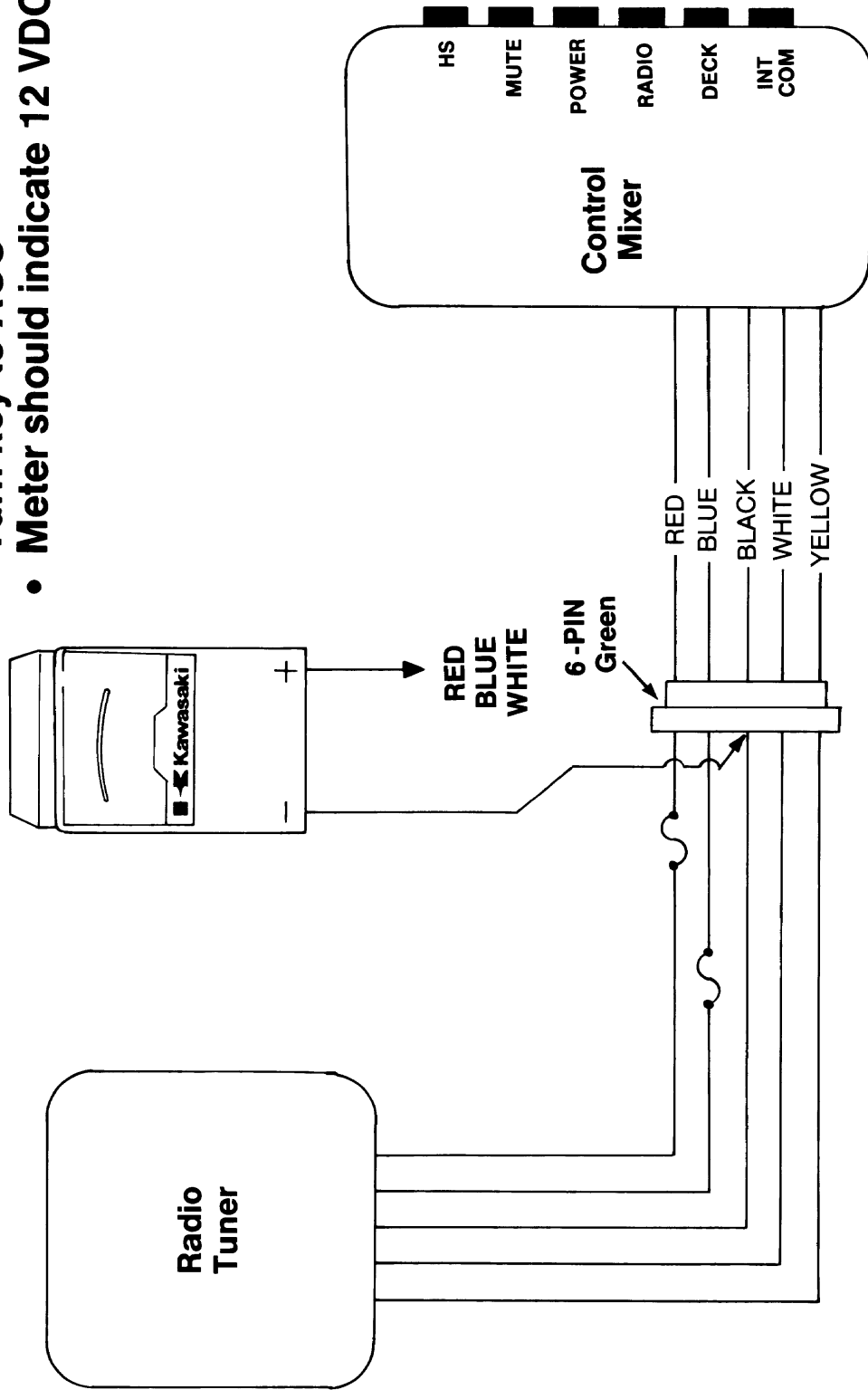

Cassette Deck Test #1

Power Through Fuse To Cassette Deck

- Turn key to ACC
- Turn cassette deck ON and insert tape
- The meter should indicate 12 VDC

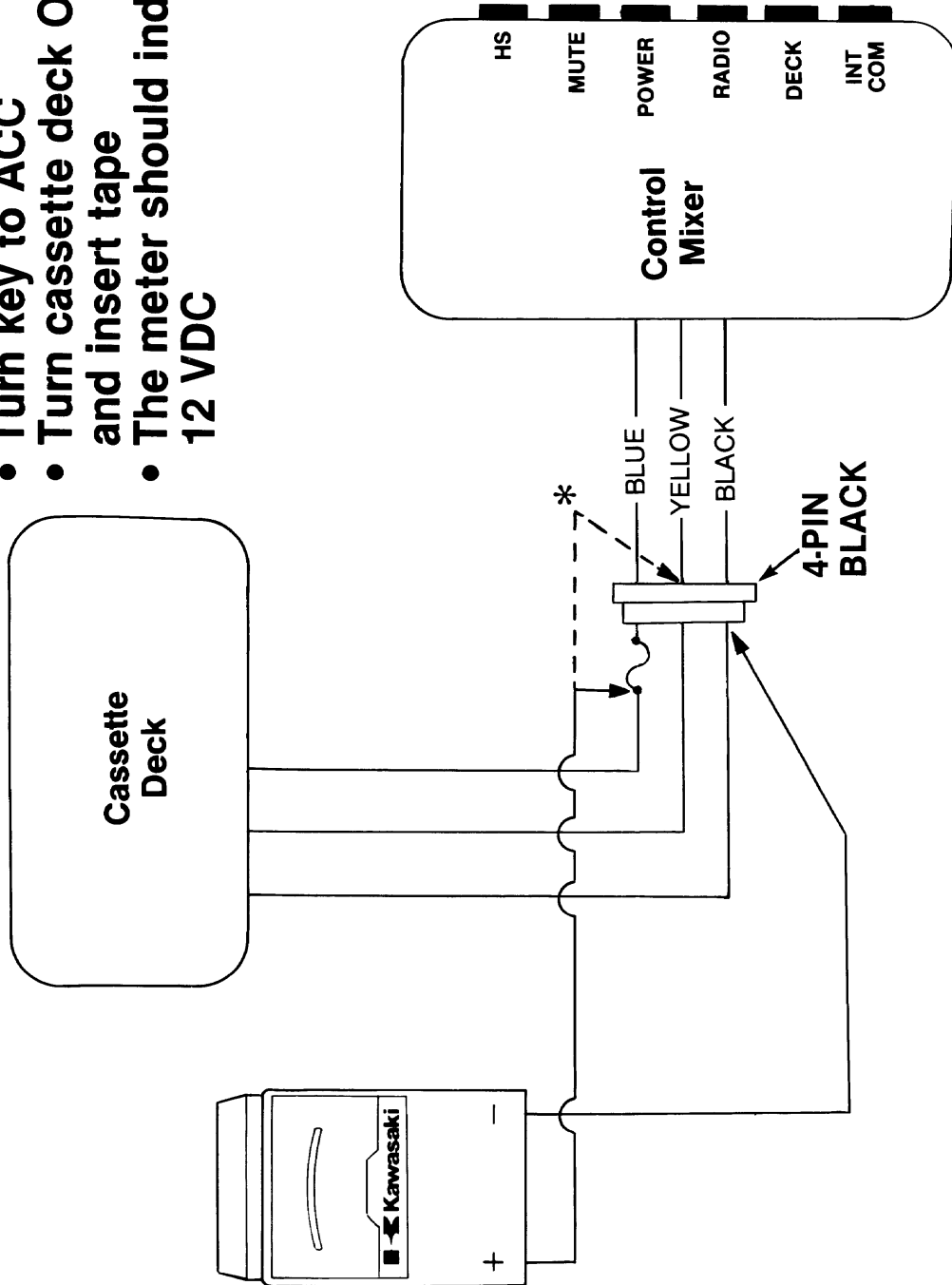

*The YELLOW wire has current from the Cassette Deck to the Control Mixer. If 12 VDC is not indicated at the YELLOW WIRE (but 12 VDC is indicated through the fuse), replace the Cassette Deck.

Radio Tuner Test #1

Power Through Fuses To Radio Tuner

- Turn key to ACC
- Turn the Radio ON
- Meter should indicate 12 VDC

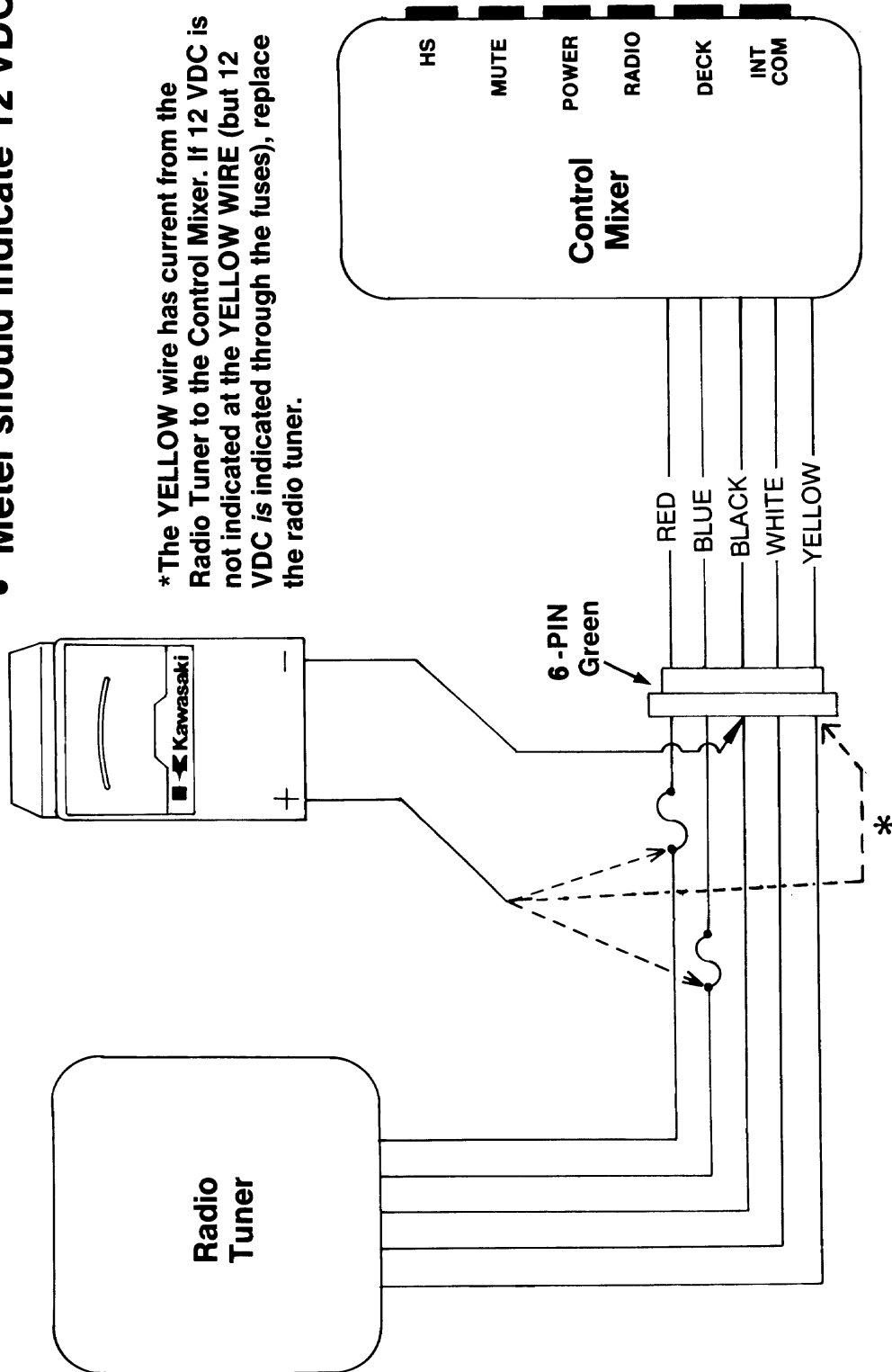

Speaker Test #1

Speaker Resistance

- Set a multimeter to the x 1 Ω scale
- Meter should indicate 3 ~ 10 ohms

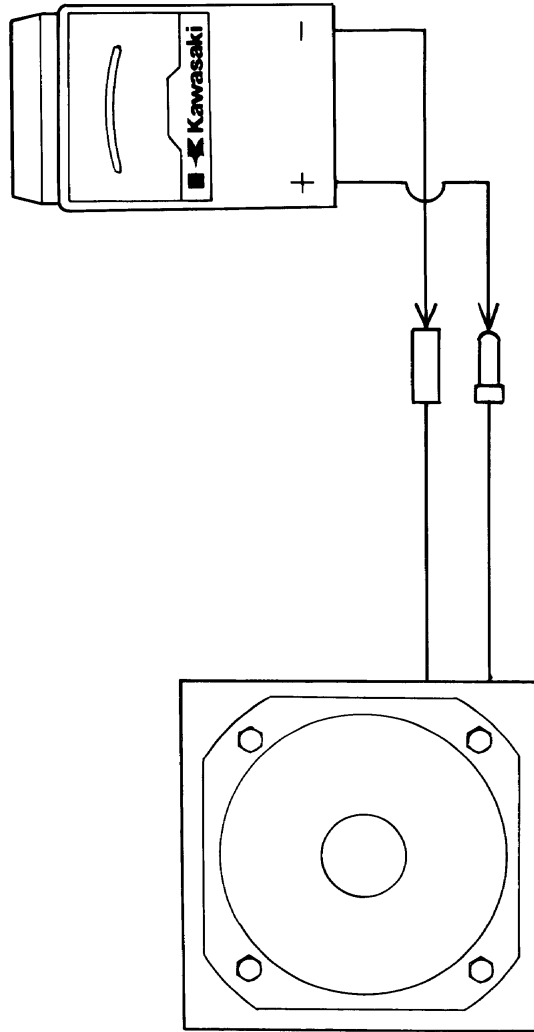

Mute Switch Test #1

Disconnect Mute Switch From Control Mixer

- Disconnect 3-PIN RED connector
- Operate Radio or Cassette Deck

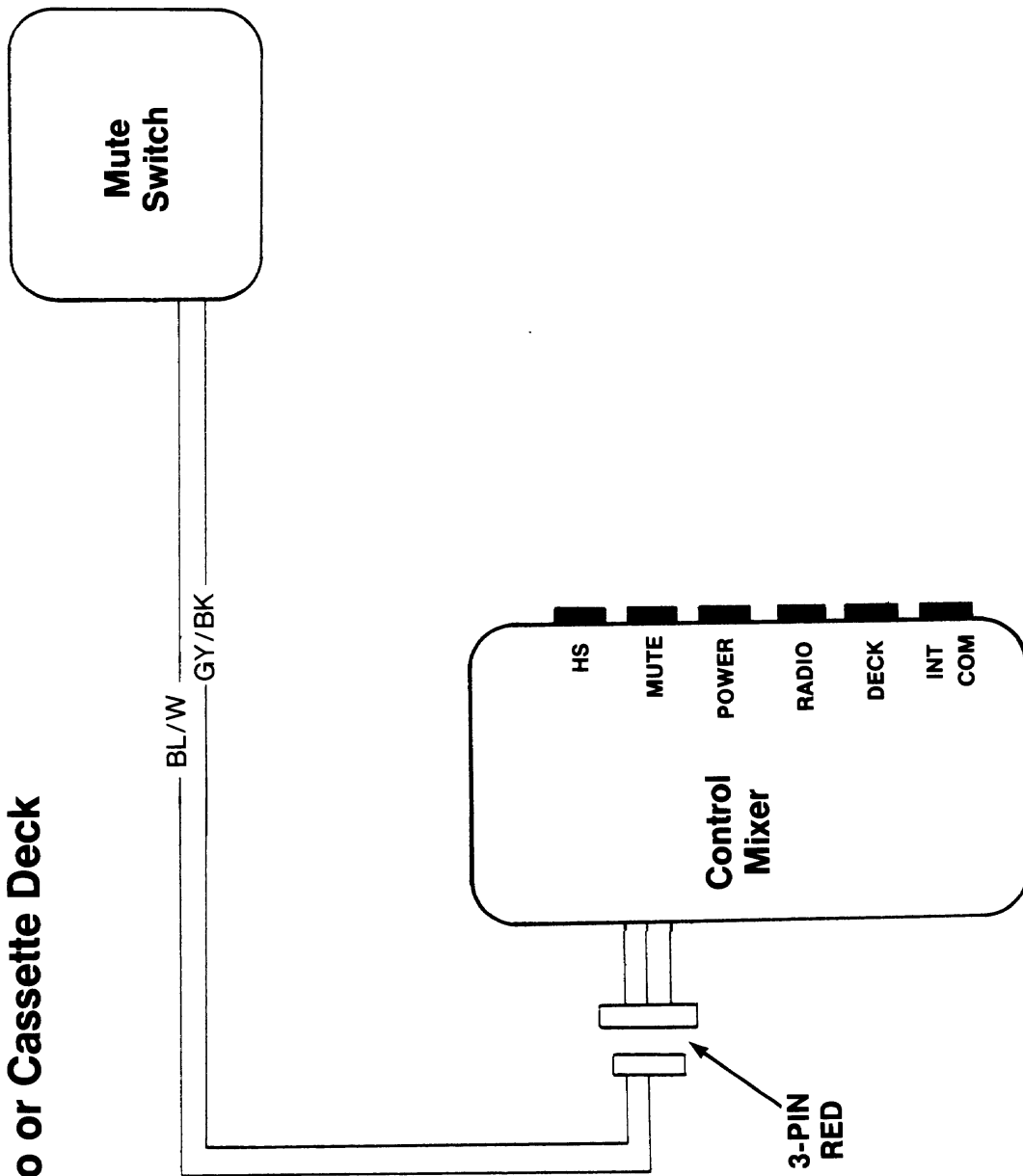

Control Mixer & Low Booster Bypass Test #1 Cassette Deck Output To Power Amplifier

TEST CONNECTIONS

- Disconnect the Cassette Deck DIN plug from the Control Mixer
- Disconnect the Power Amplifier DIN plug from the Low Booster
- Connect the Test Harness as shown
- Turn the key to ACC
- Operate the Cassette Deck

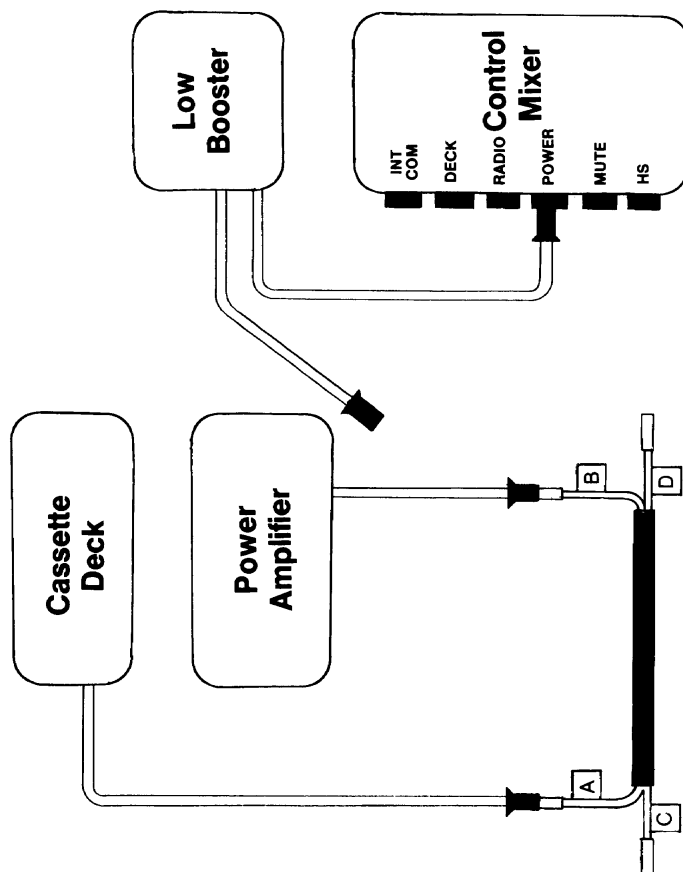

STANDARD CONNECTIONS

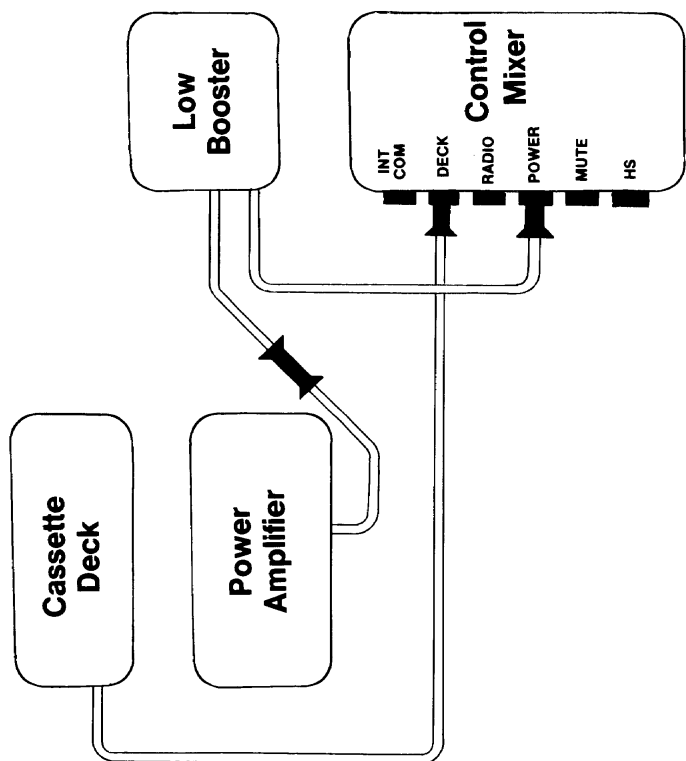

Control Mixer & Low Booster Bypass Test #2 Radio Output To Power Amplifier

TEST CONNECTIONS

- Disconnect the Power Amplifier DIN plug from the Low Booster
- Disconnect the Radio Tuner DIN plug from the Control Mixer
- Connect the Test Harness as shown
- Turn the key to ACC
- Operate the Radio

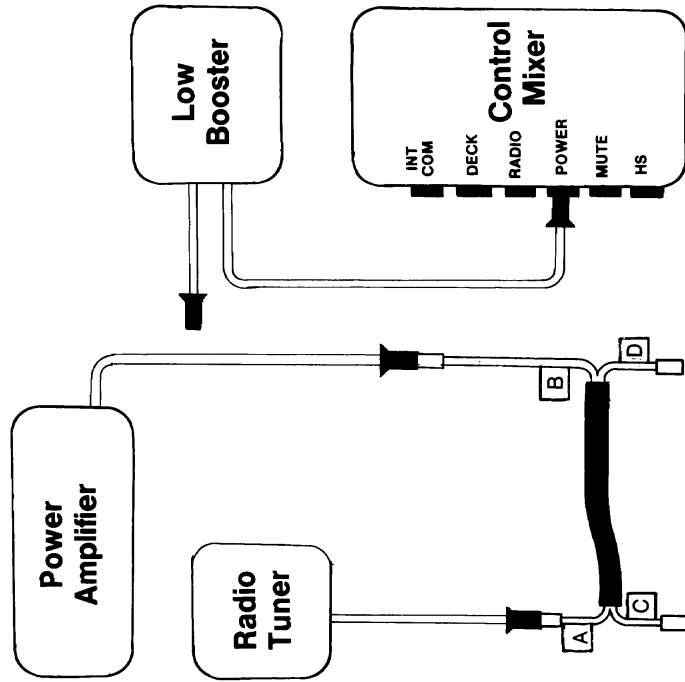

STANDARD CONNECTIONS

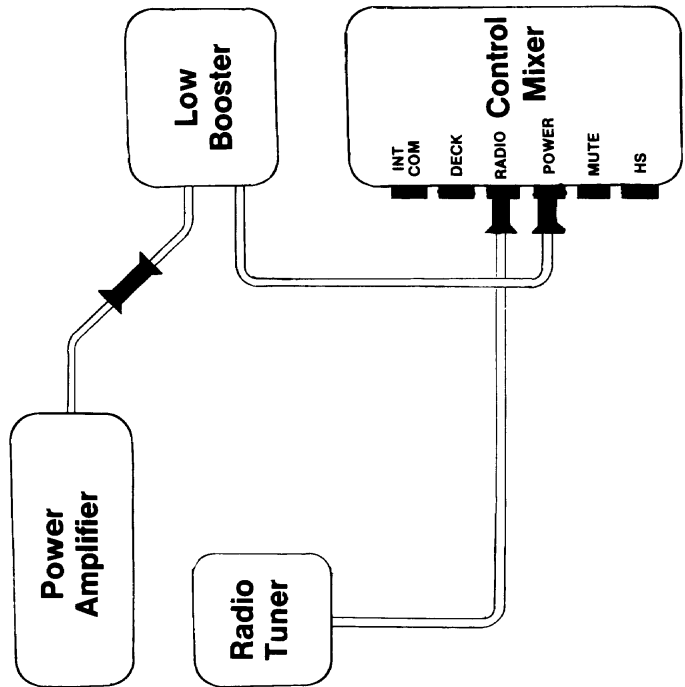

Control Mixer Bypass Test #1

Cassette Deck Output To Low Booster

STANDARD CONNECTIONS

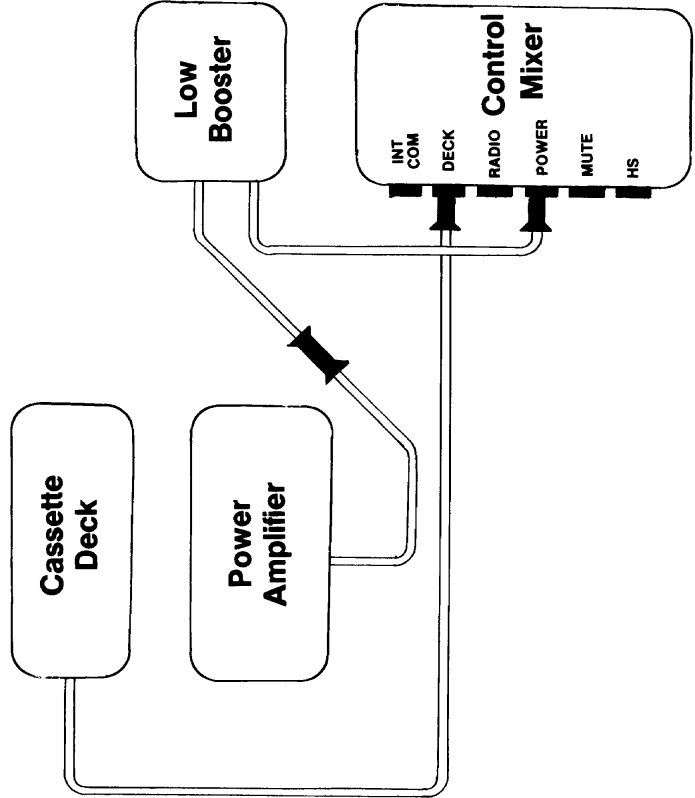

TEST CONNECTIONS

- Disconnect the Low Booster DIN plug from the Control Mixer
- Disconnect the Cassette Deck DIN plug from the Control Mixer
- Connect the Test Harness as shown
- Turn the key to ACC
- Operate the Cassette Deck

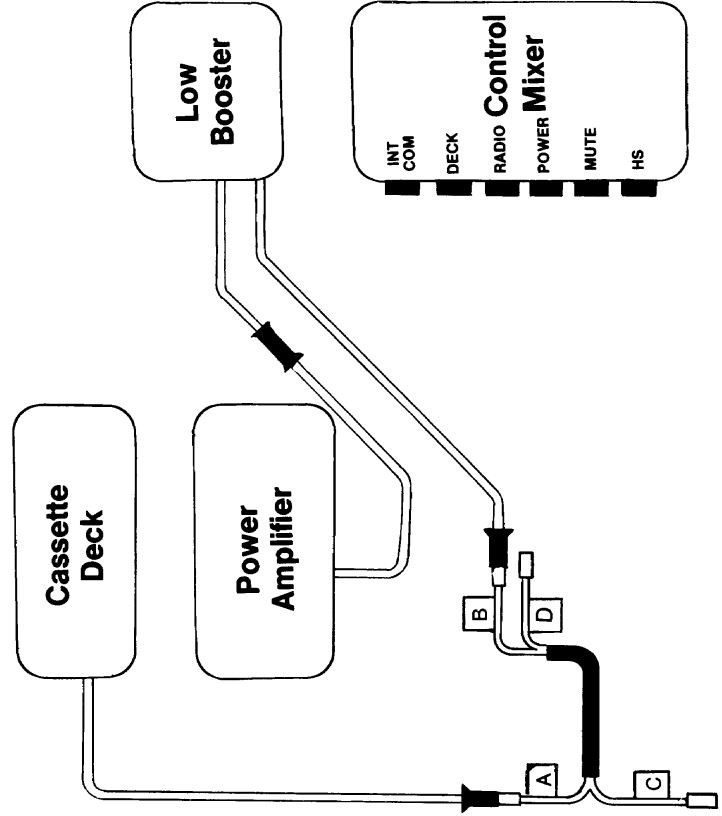

Control Mixer Bypass Test #2 Radio Output To Power Amplifier

TEST CONNECTIONS

- Disconnect the Radio Tuner DIN plug from the Control Mixer
- Disconnect the Low Booster DIN plug from the Control Mixer
- Connect the Test Harness as shown
- Turn the key to ACC
- Operate the Radio

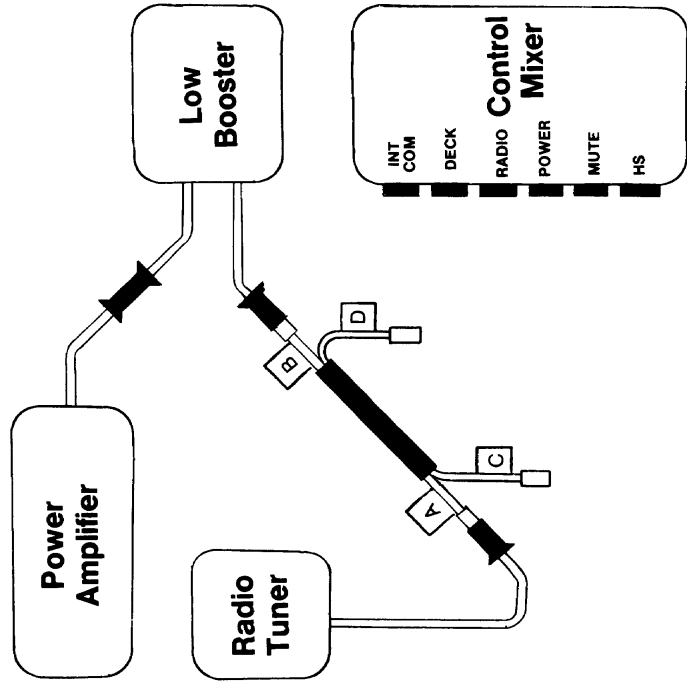

STANDARD CONNECTIONS

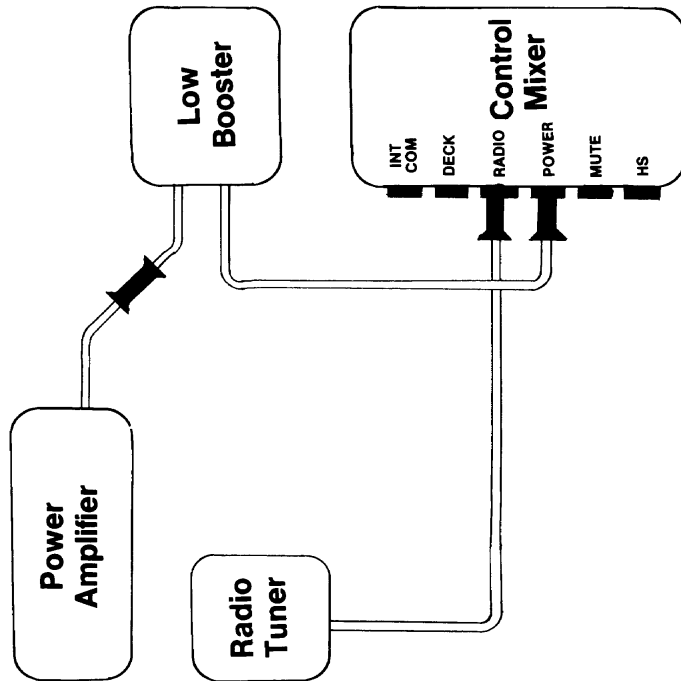

Special Test # 1

Low Booster Bypass

TEST CONNECTIONS

- Disconnect the Low Booster DIN plug from the Control Mixer
- Disconnect the Low Booster DIN plug from the Power Amplifier
- Connect the Test Harness as shown
- Turn the key to ACC
- Operate the Radio

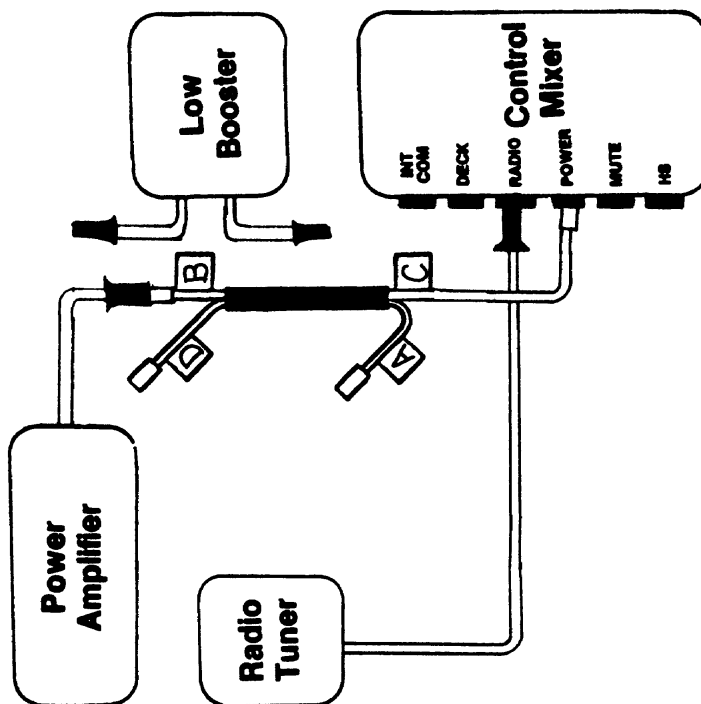

STANDARD CONNECTIONS

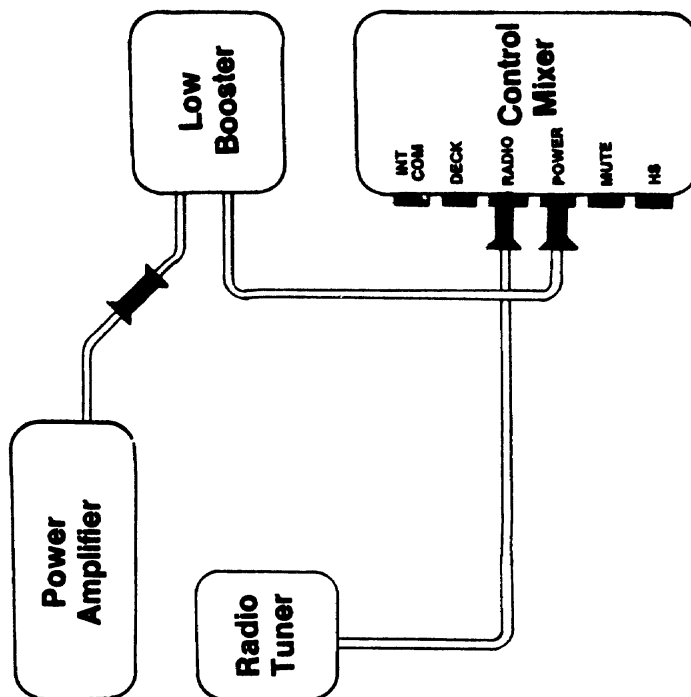

No Sound From Cassette Deck (only)

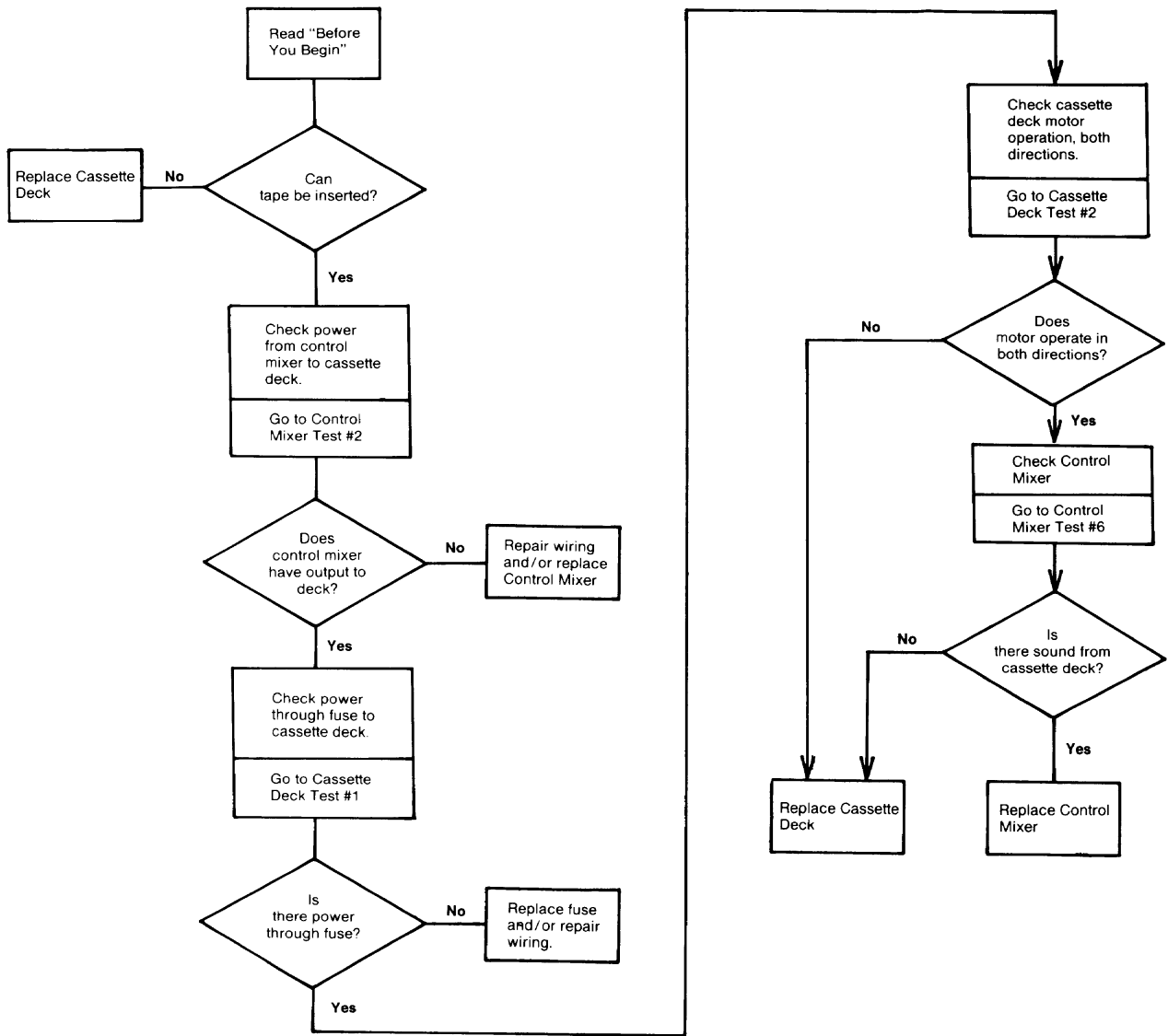

Control Mixer Test #2

Control Mixer Output To Cassette Deck

- Turn key to ACC
- Meter should indicate 12 VDC

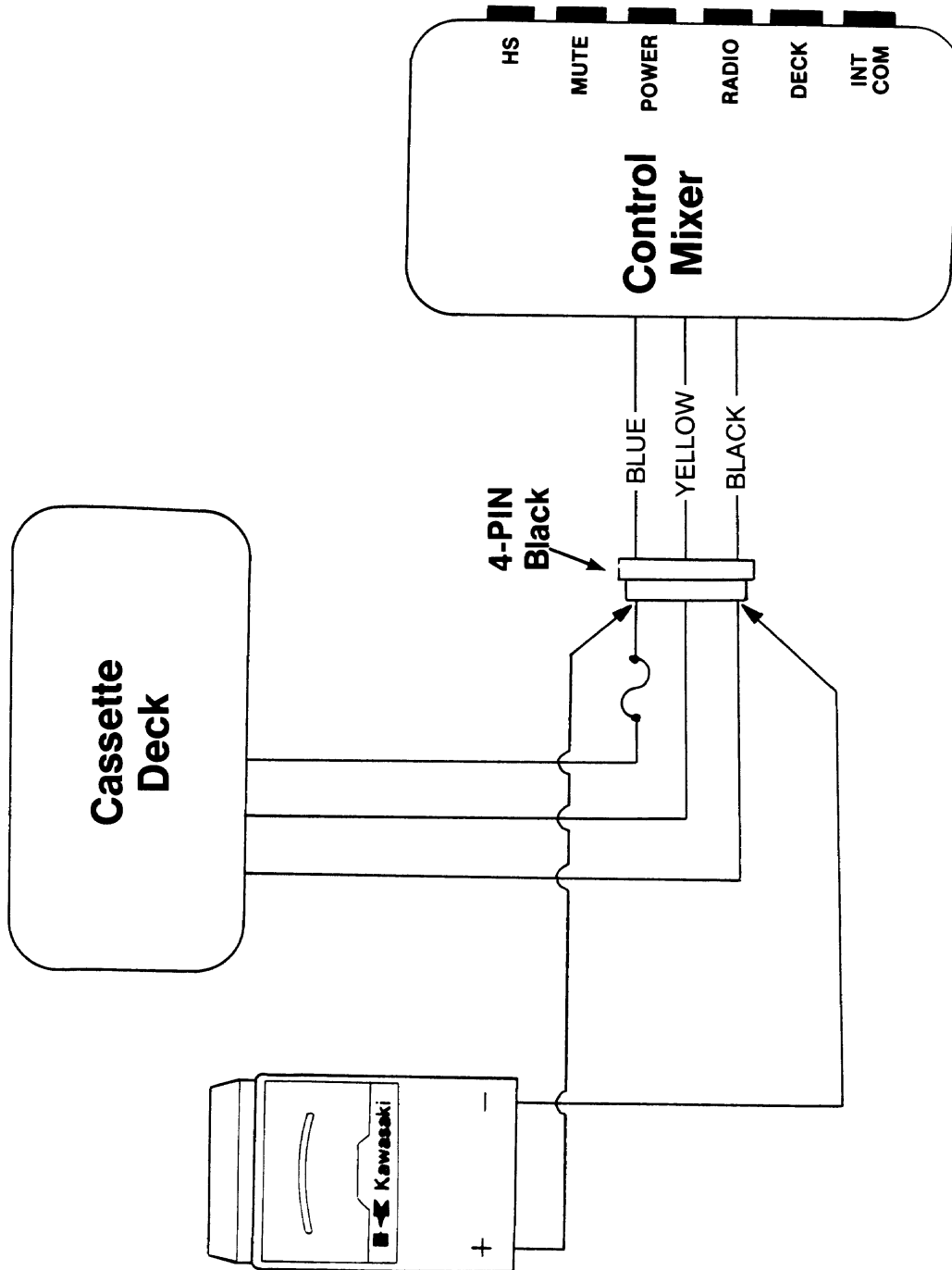

Cassette Deck Test #1

Power Through Fuse To Cassette Deck

- Turn key to ACC
- Turn Cassette Deck ON and insert tape
- Meter should indicate 12 VDC

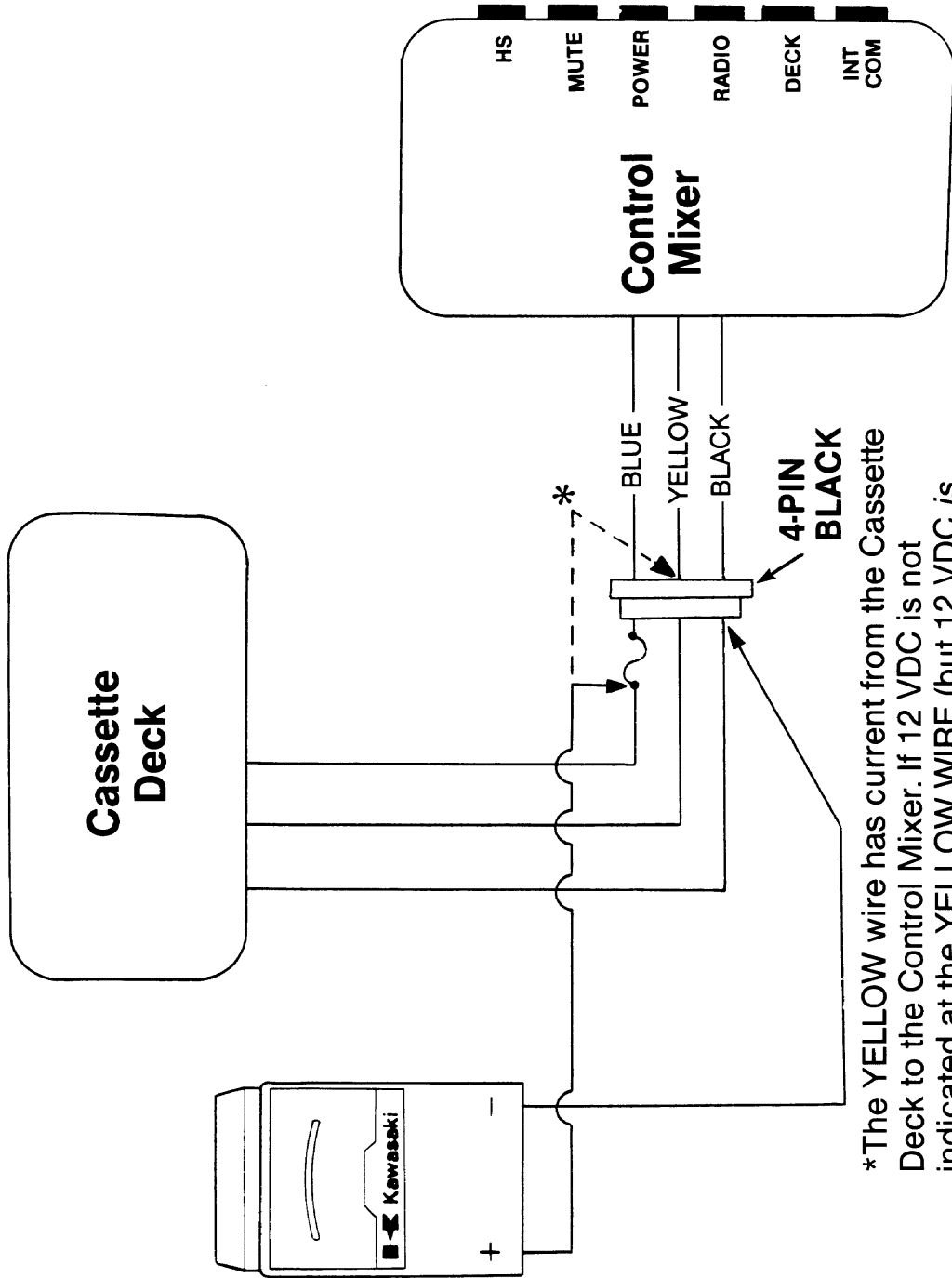

*The YELLOW wire has current from the Cassette Deck to the Control Mixer. If 12 VDC is not indicated at the YELLOW WIRE (but 12 VDC is indicated through the fuse), replace the Cassette Deck.

Cassette Deck Test #2

Cassette Deck Motor Operation

- Turn the key to ACC
- Using the eraser end of a pencil, gently push in the cross bar which is visible through the Cassette Deck front opening.
- One drive wheel and one program indicator light should function. Push the PROGRAM button to operate the other drive wheel and indicator light.
- Push the STOP ■ EJECT button to turn off the Cassette Deck

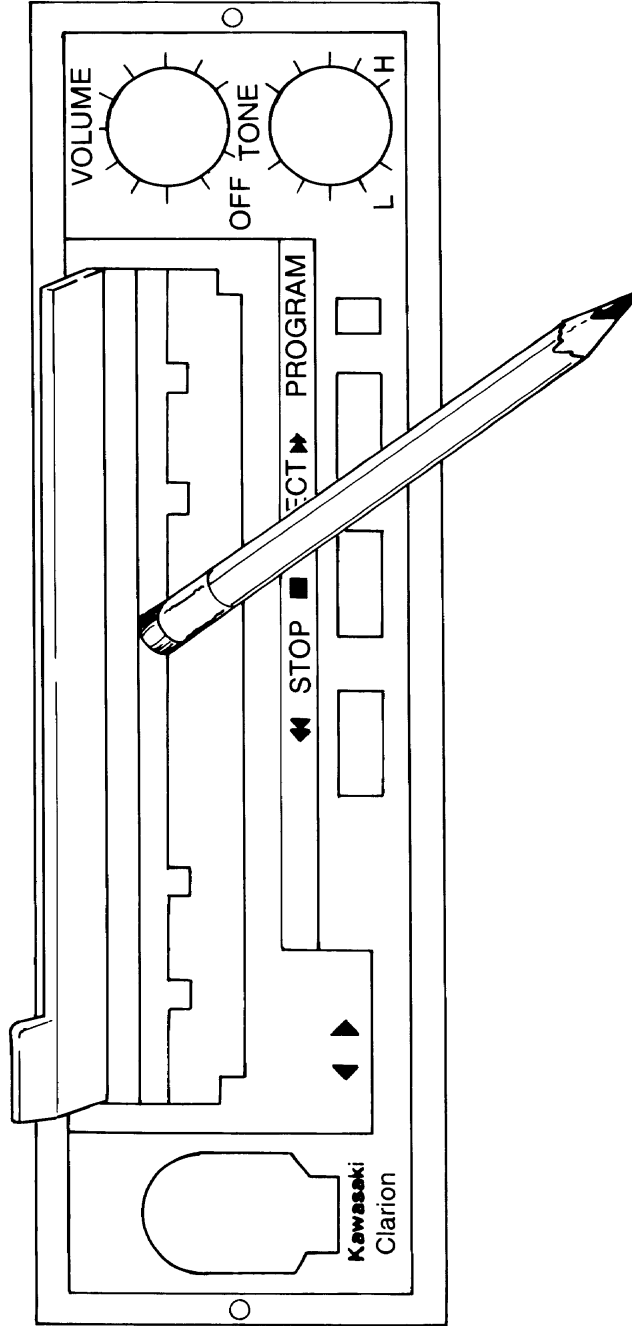

Control Mixer Test #6

Control Mixer Cassette Deck Circuit

Standard Connection

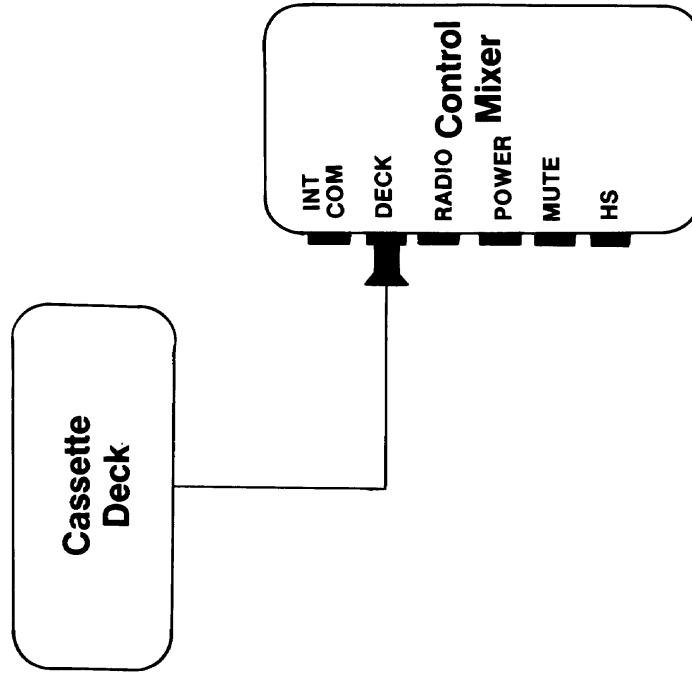

Test Connection

- Plug Cassette Deck DIN lead into RADIO DIN socket at Control Mixer
- Turn key to ACC
- Turn cassette Deck ON and insert tape

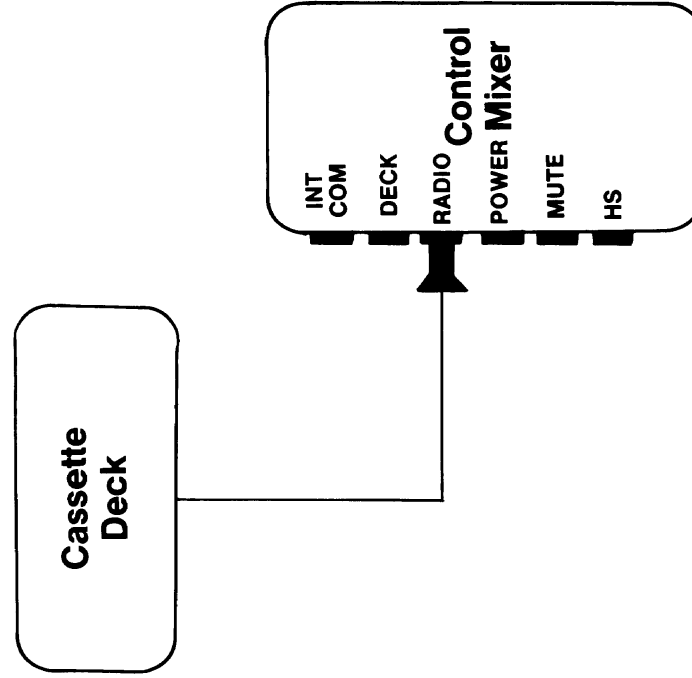

No Sound From Radio (only)

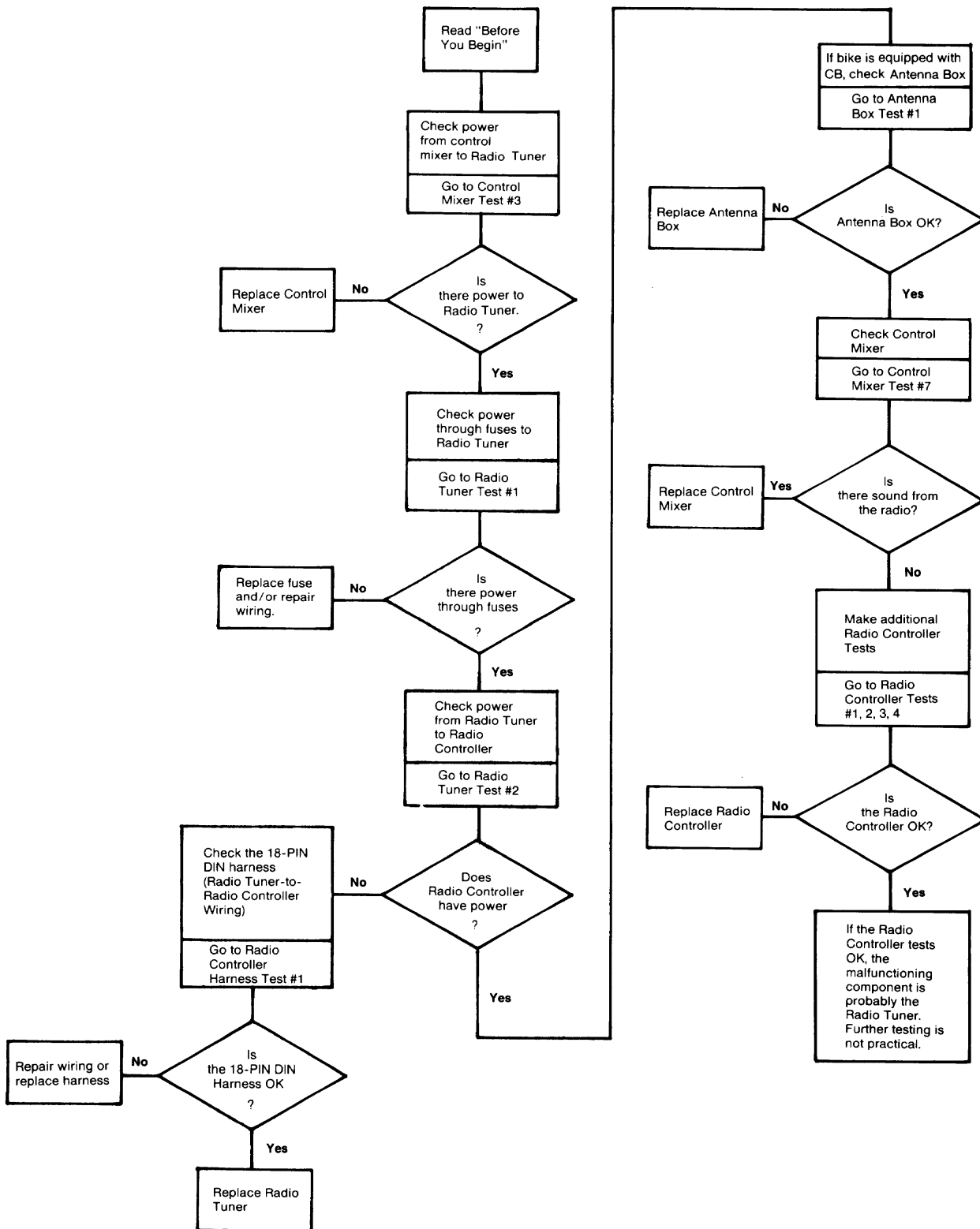

Control Mixer Test #3

Control Mixer Output To Radio Tuner

- Turn key to ACC
- Meter should indicate 12 VDC

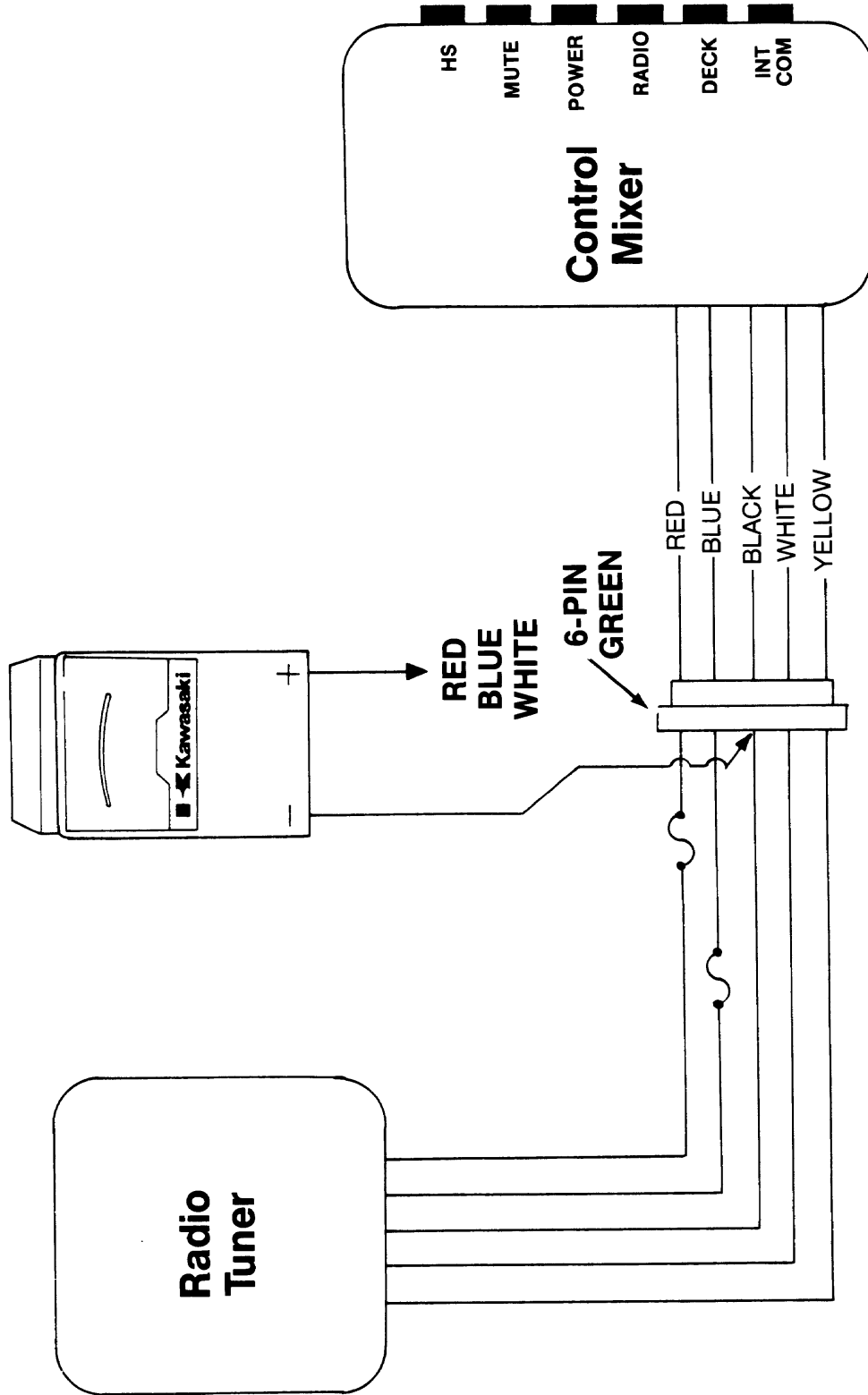

Radio Tuner Test #2

Radio Tuner Output To Radio Controller

- Remove Radio Controller
- Turn key to ACC
- Meter should indicate as follows:

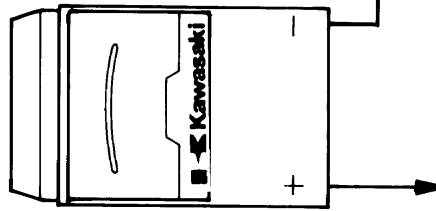
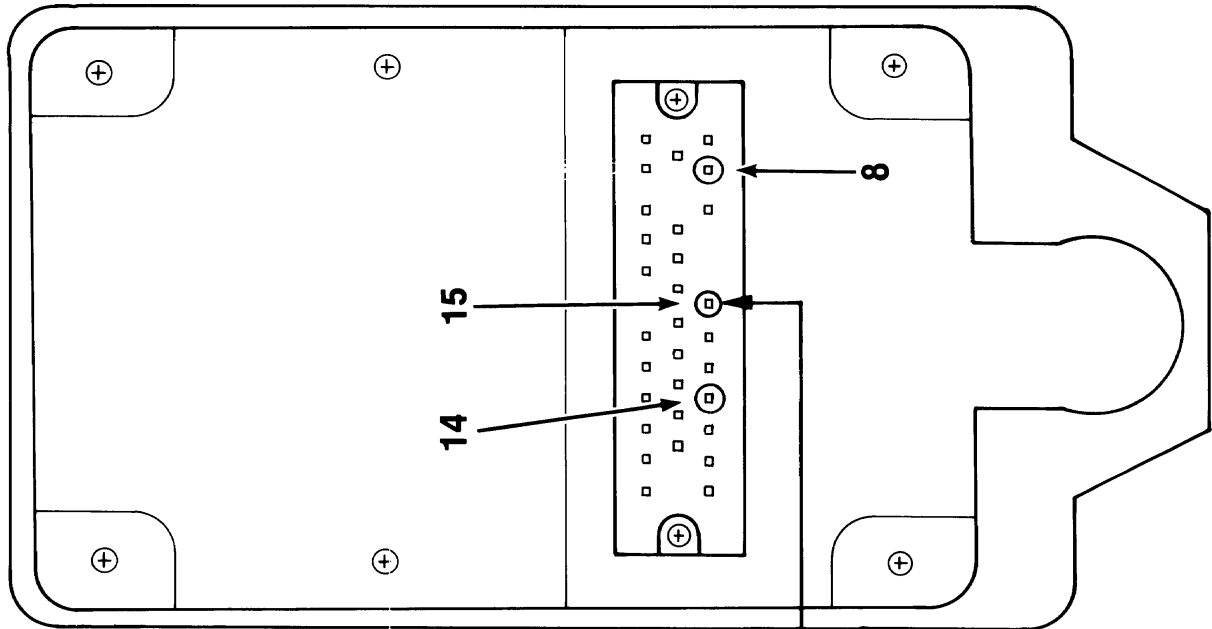

PIN #8 = 5 ~ 6 VDC
PIN #14 = 12 VDC

No Sound From Radio (only)

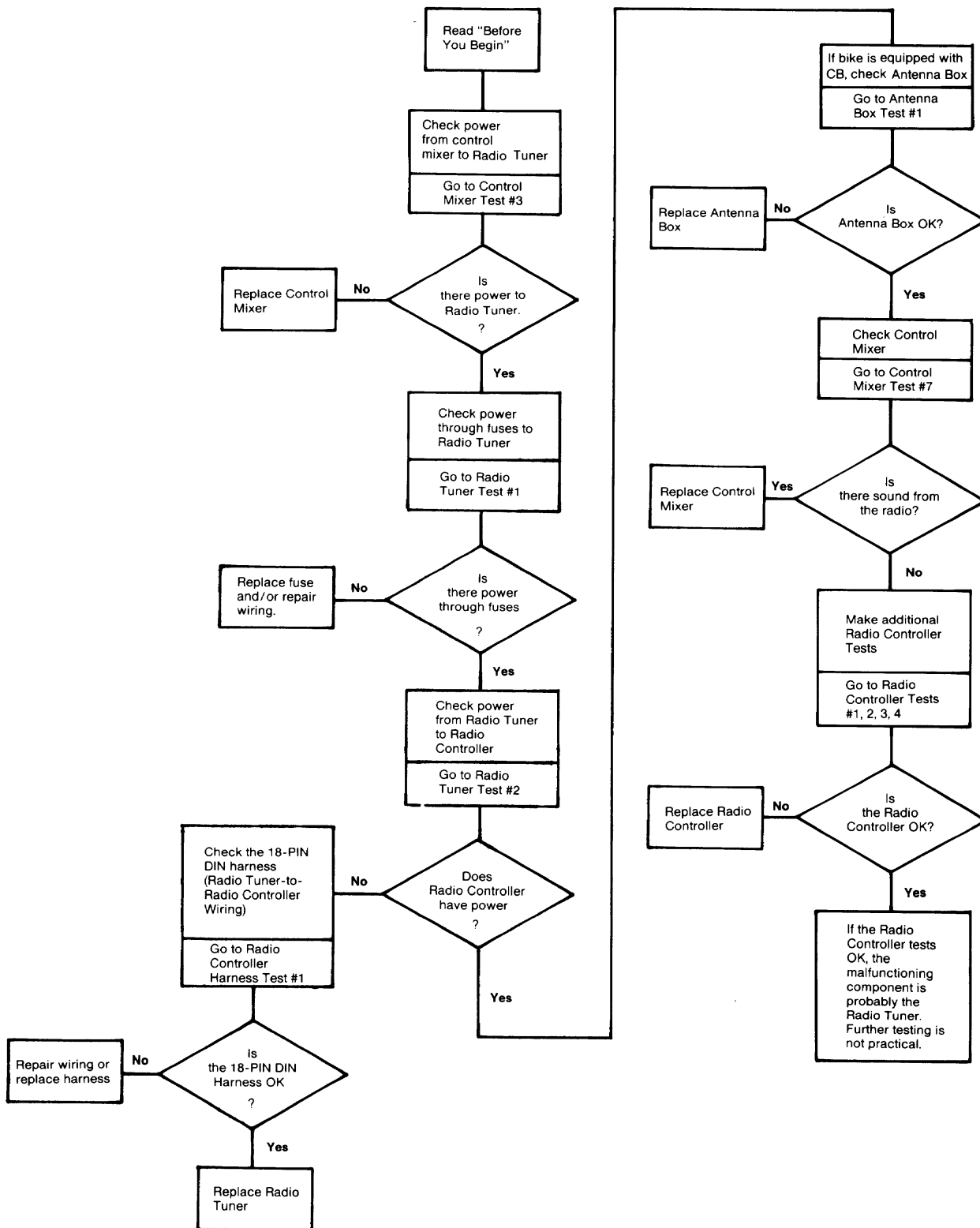

Control Mixer Test #3

Control Mixer Output To Radio Tuner

- Turn key to ACC
- Meter should indicate 12 VDC

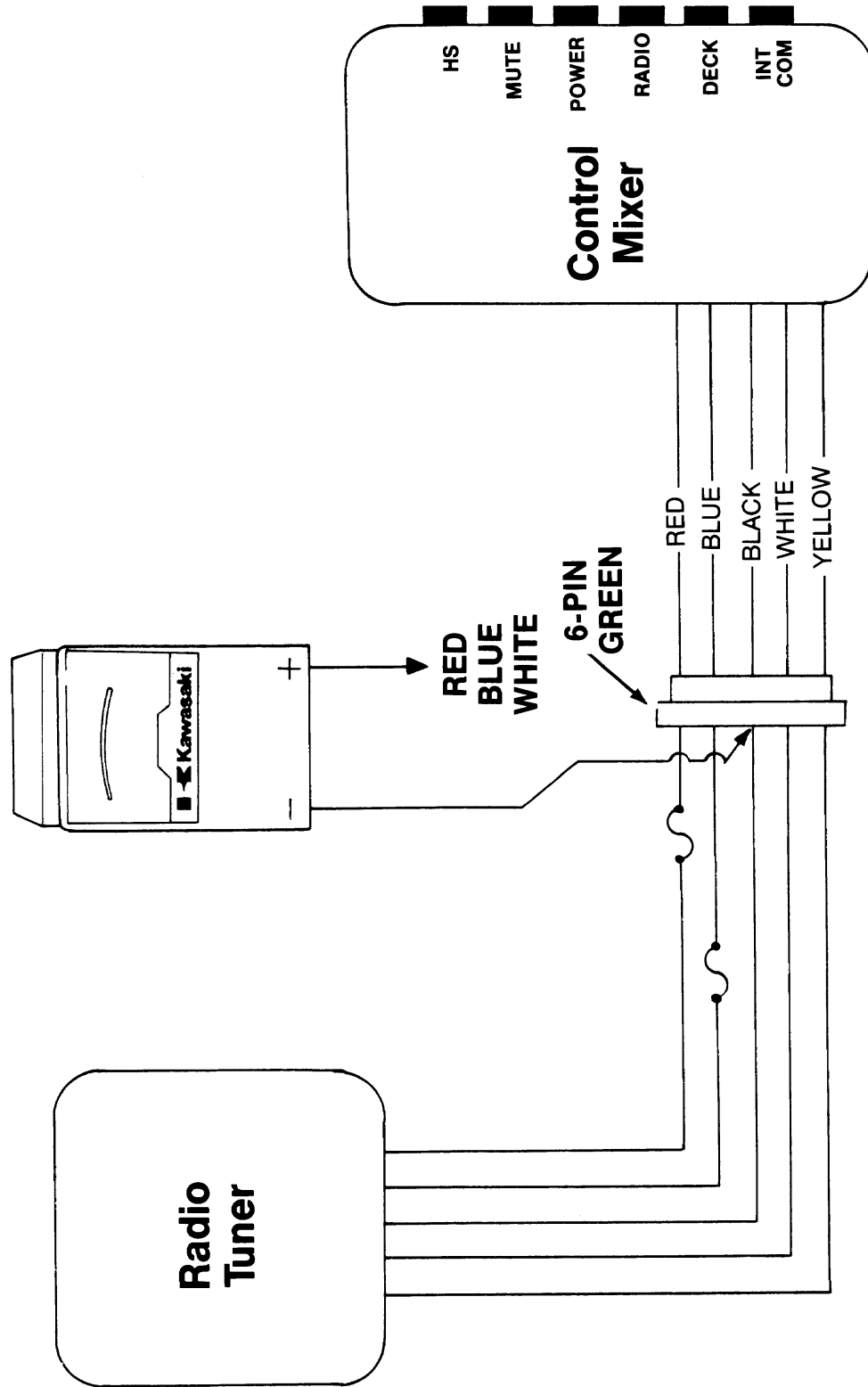

Radio Controller Harness Test #1

18 PIN DIN Harness Continuity

- Remove the Radio Controller and Controller Case
- Disconnect the 18-PIN DIN plug
- Set a multimeter to the x 1 Ω scale
- Connect meter leads to the corresponding pins in the DIN plug and the Radio Controller case plug
- The meter should indicate almost 0 Ω

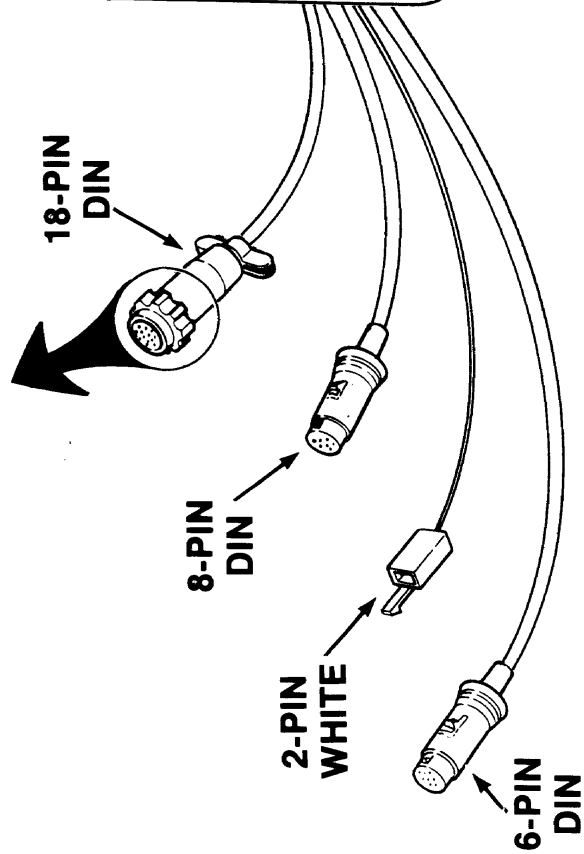
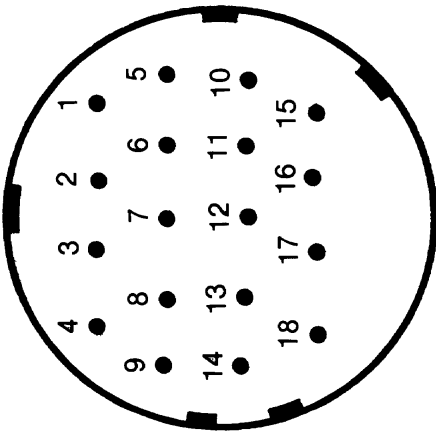
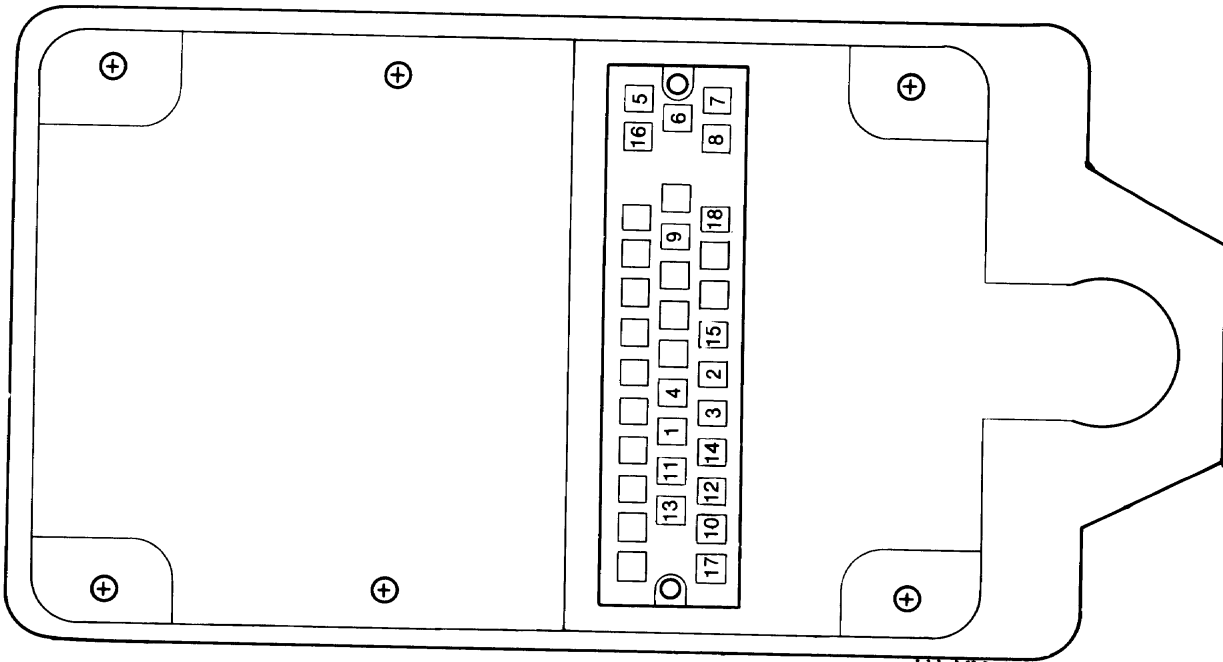

Antenna Box Text #1

Radio Circuit Bypass

Test Connections

- Disconnect Antenna Cables from Antenna Box as shown
- Connect Test Cable as shown
- Operate Radio

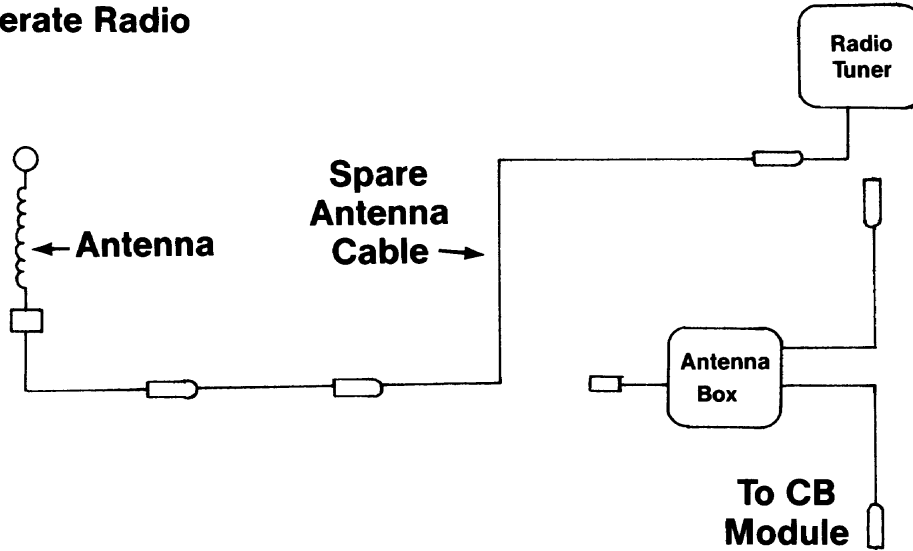

Standard Connections

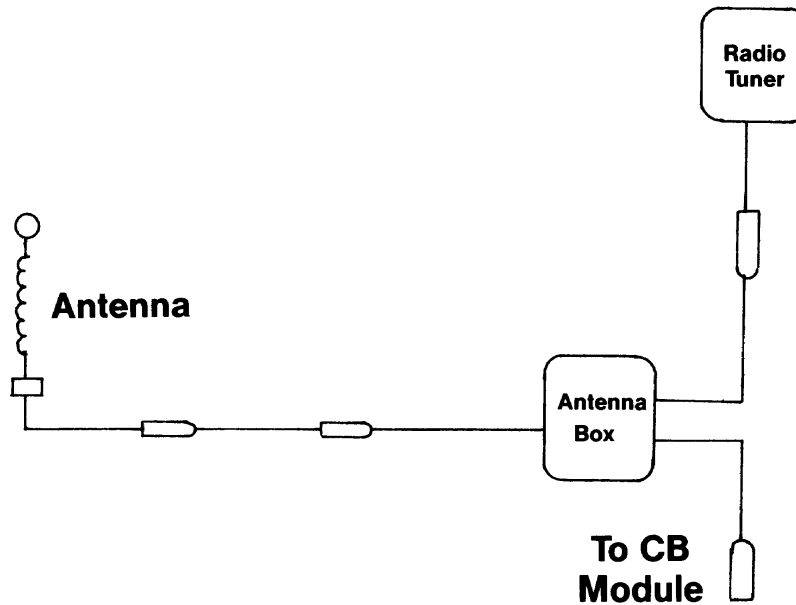

Control Mixer Test #7

Control Mixer Radio Tuner Circuit

Standard Connection

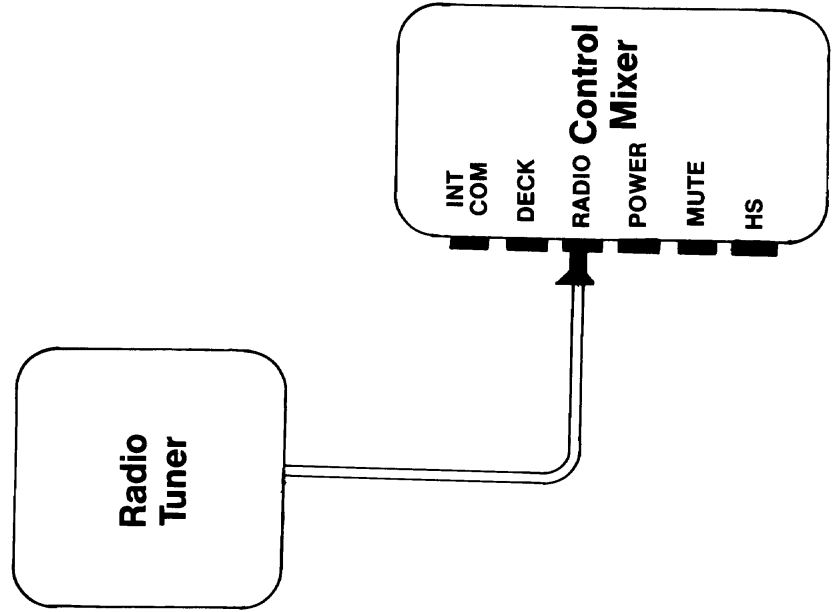

Test Connection

- Plug Radio Tuner DIN lead into DECK DIN socket at Control Mixer

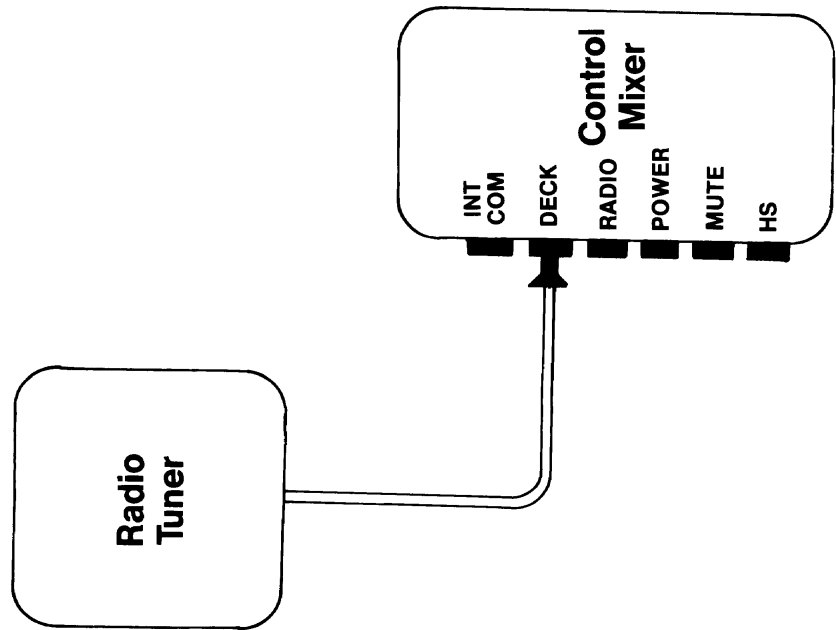

Radio Controller Test #1

Controller Ground

- Remove the Radio Controller
- Set a multimeter to the x1K Ω scale
- Connect the meter leads as shown
- With the Radio Controller knobs in any position, the meter should indicate 0 Ω

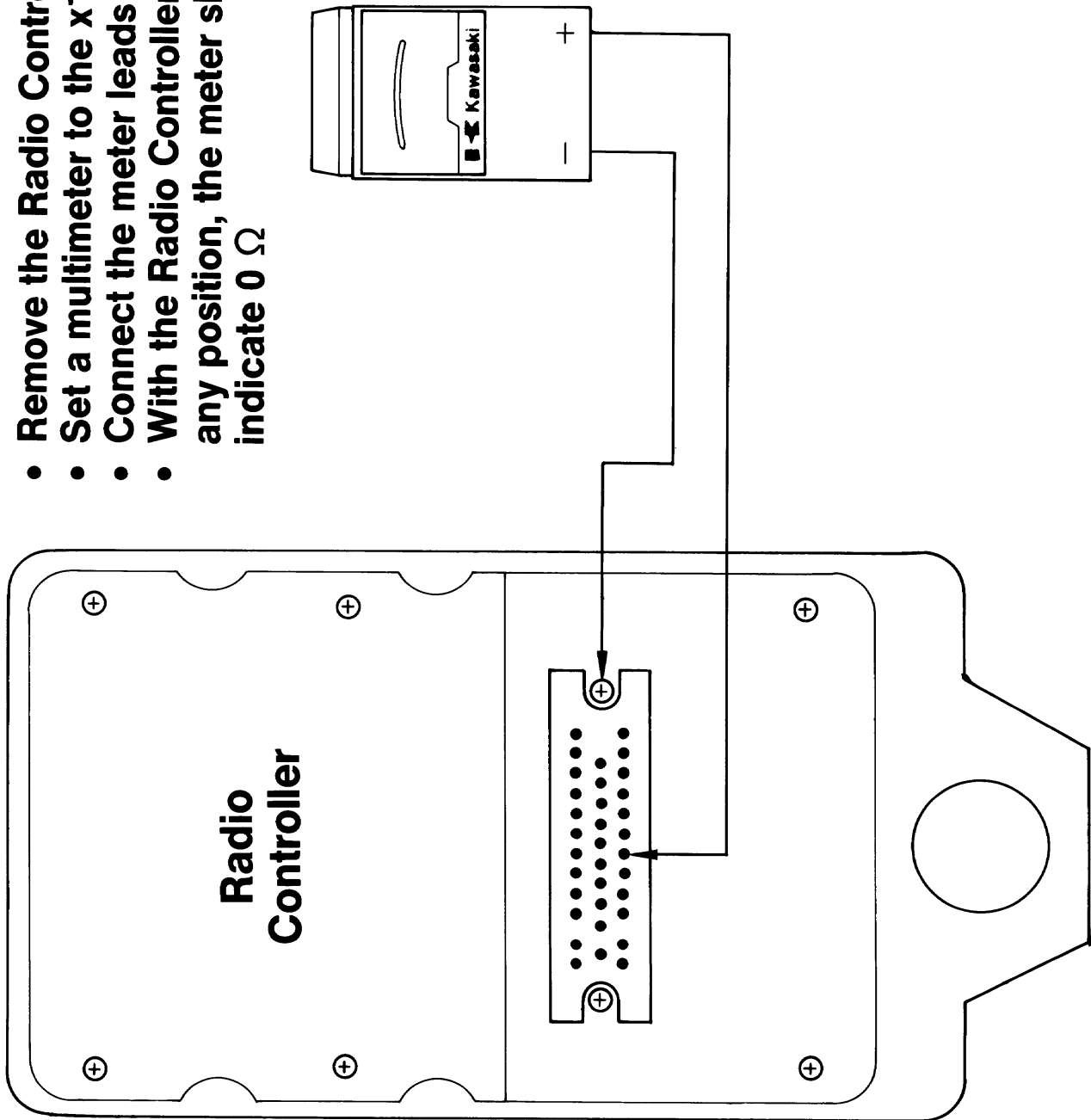

Radio Controller Test #2

On/Off Switch

- Remove the Radio Controller
- Set a multimeter to the x1K Ω scale
- Connect the meter leads as shown
- With the VOLUME knob in the OFF position, the meter should indicate $\infty \Omega$
- With the VOLUME knob in any ON position, the meter should indicate 0 Ω

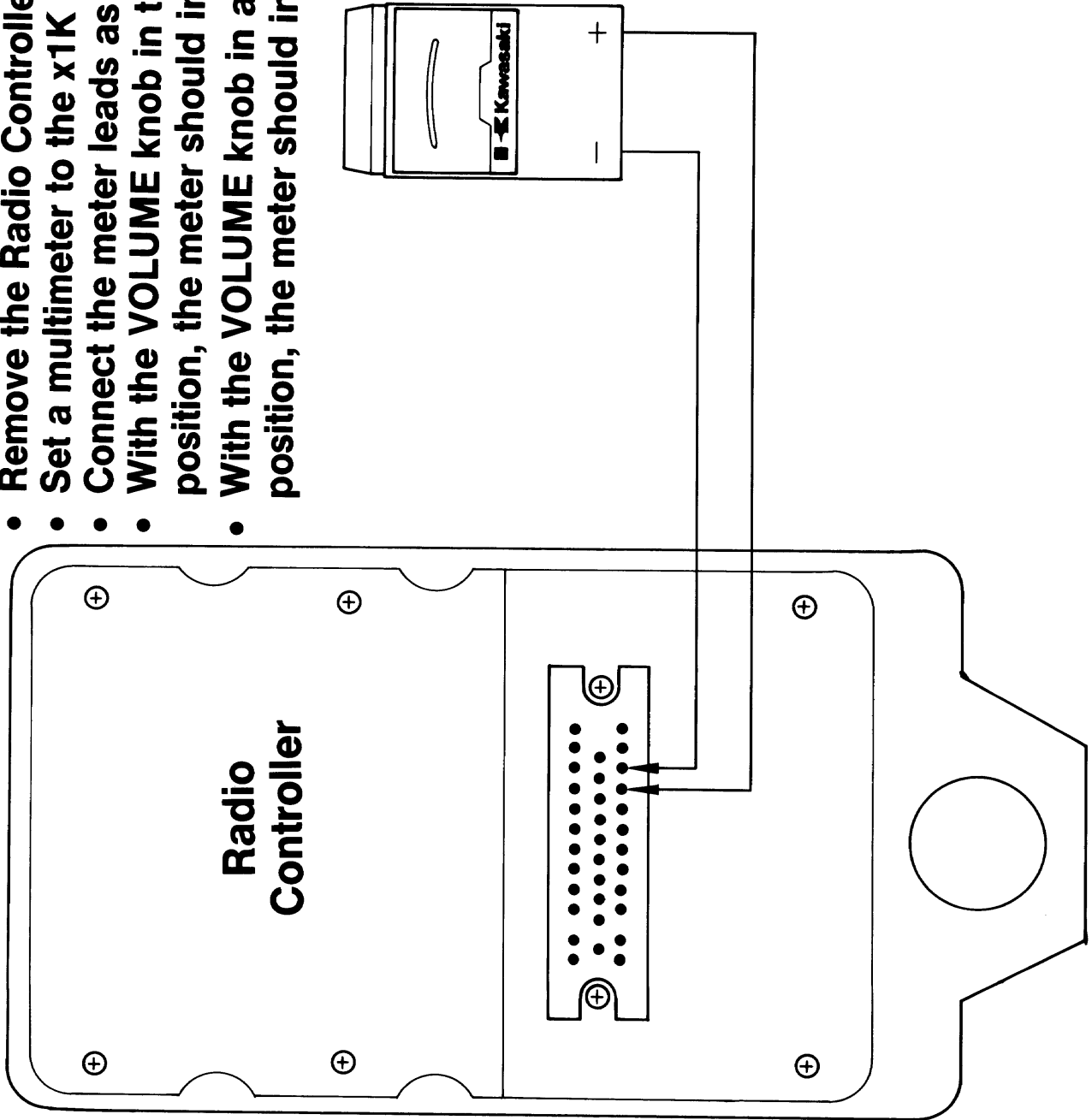

Radio Controller Test #3

Volume Control

- Remove the Radio Controller
- Set a multimeter to the x1K Ω scale
- Connect the meter leads as shown
- With the VOLUME knob in the OFF position, the meter should indicate about 20K Ω
- With the VOLUME knob in the FULL RIGHT position, the meter should indicate 0 Ω

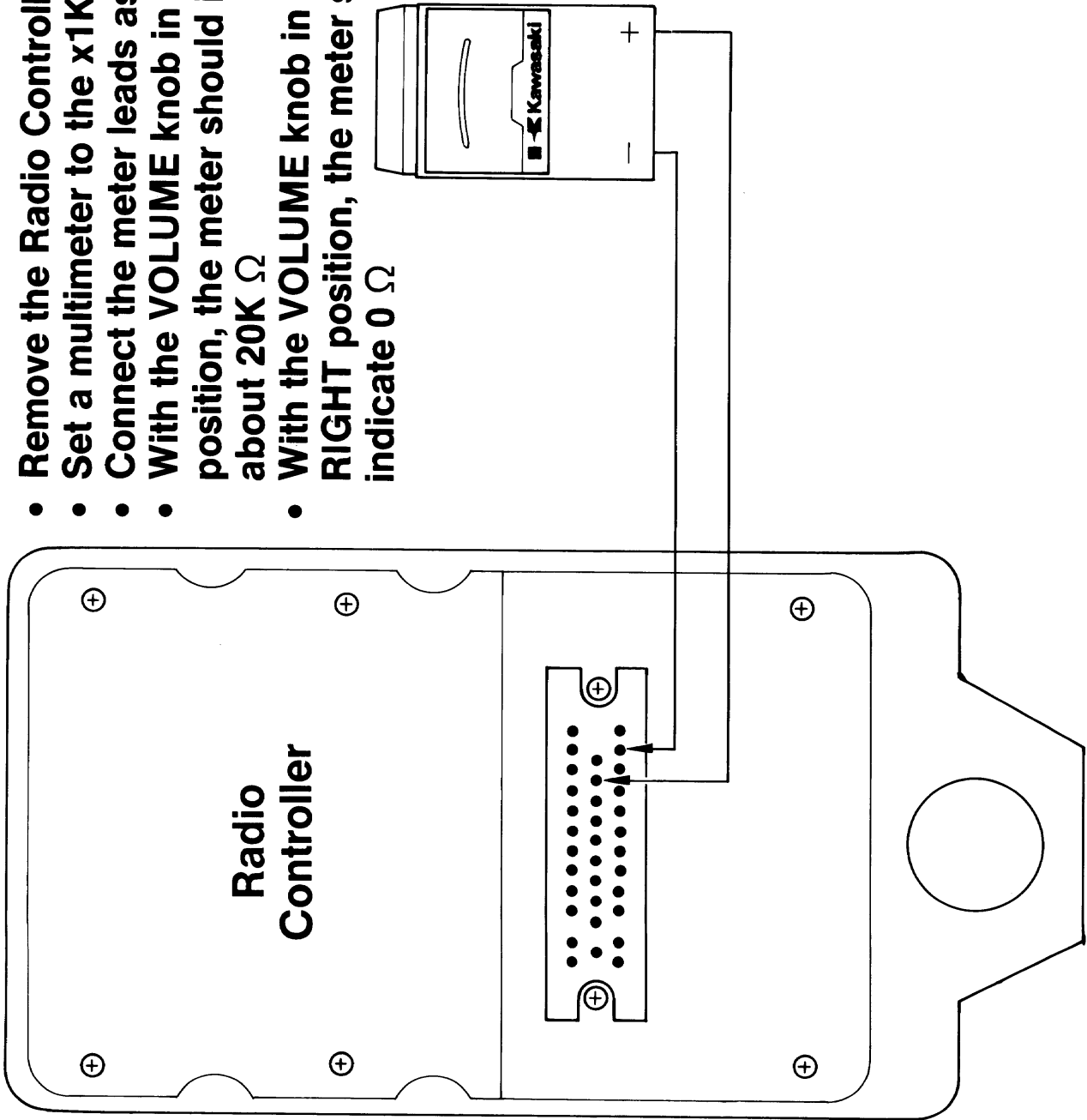

Radio Controller Test #4 Tone Control

- Remove the Radio Controller
- Set a multimeter to the x1K Ω scale
- Connect the meter leads as shown
- With the TONE knob in the L position, the meter should indicate about 20K Ω
- With the TONE knob in the H position, the meter should indicate almost 0 Ω

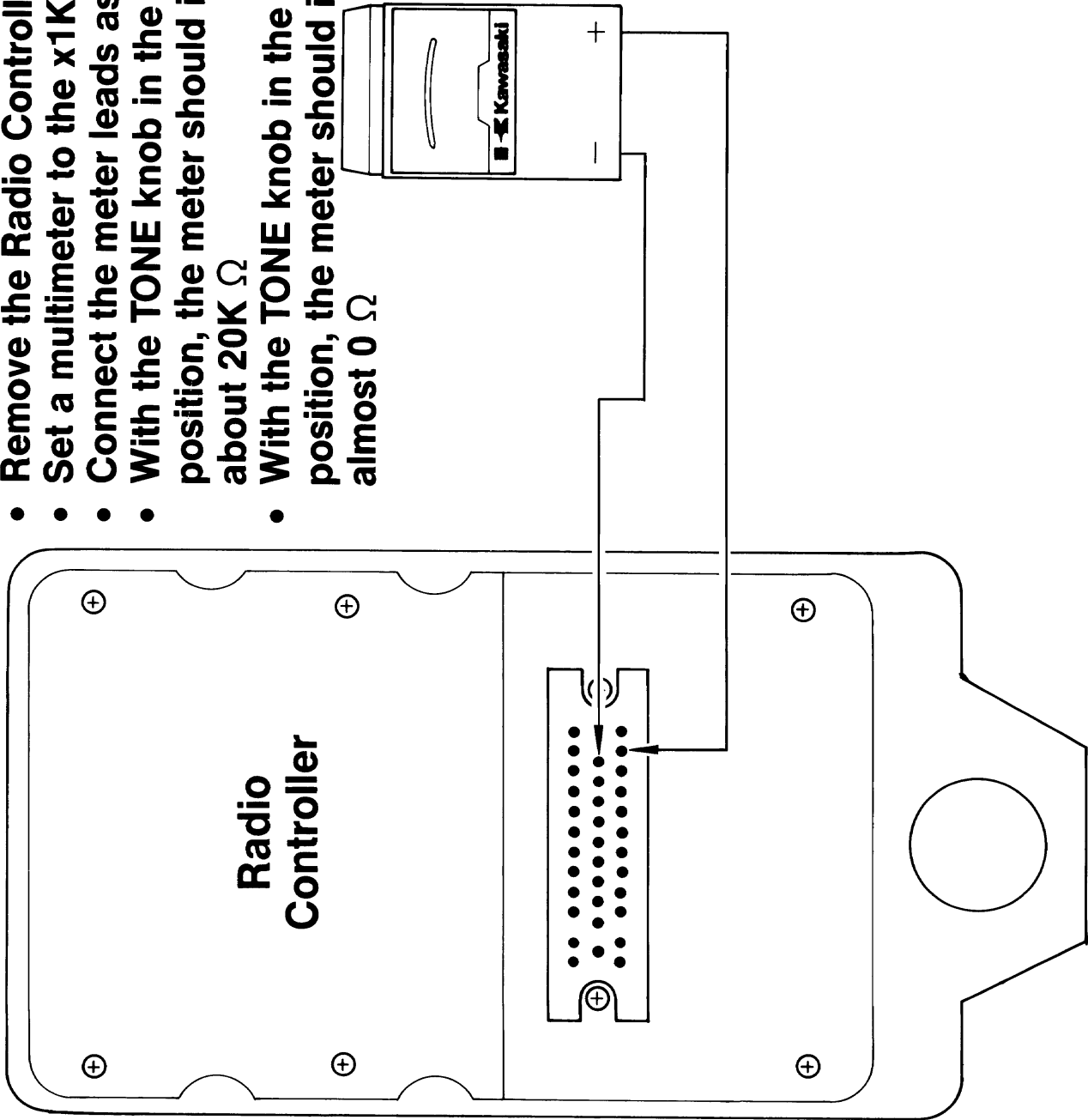

Radio Difficulty

Handlebar Switch

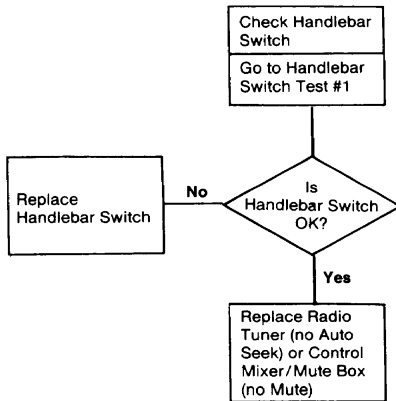

Radio Display

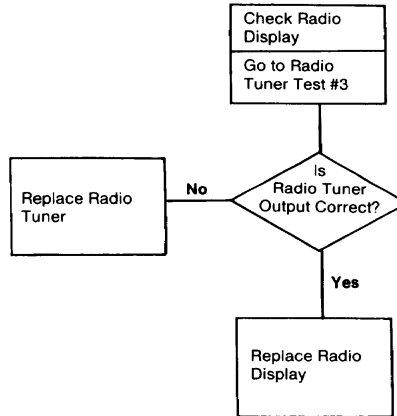

Poor Reception

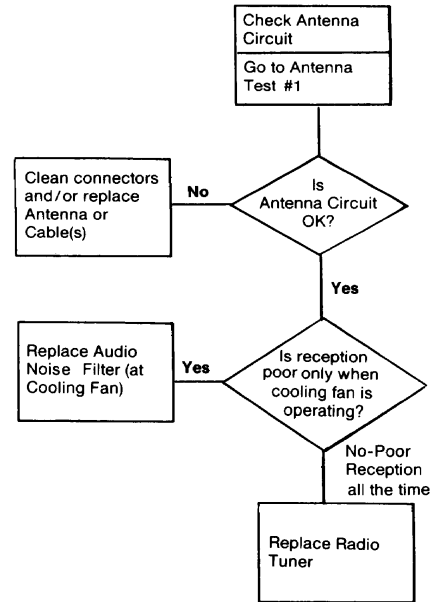

Handlebar Switch Test #1

Auto Seek & Mute Operation

Auto Seek Tune

- Disconnect the 4-PIN WHITE connector.
- Set a multimeter to the x 1 Ω scale.
- Connect the meter leads to the GREEN/YELLOW and ORANGE wires
- With the Auto Seek button released, the meter should indicate $\infty \Omega$
- With the Auto Seek button pushed the meter should indicate almost 0 Ω

Mute

- Disconnect the 4-PIN WHITE connector
- Set a multimeter to the x 1 Ω scale
- Connect the meter leads to the BLUE/WHITE and GRAY/BLACK wires
- With the Mute Switch in the OFF position (left), the meter should indicate $\infty \Omega$
- With the Mute Switch in the ON position (right), the meter should indicate almost 0 Ω

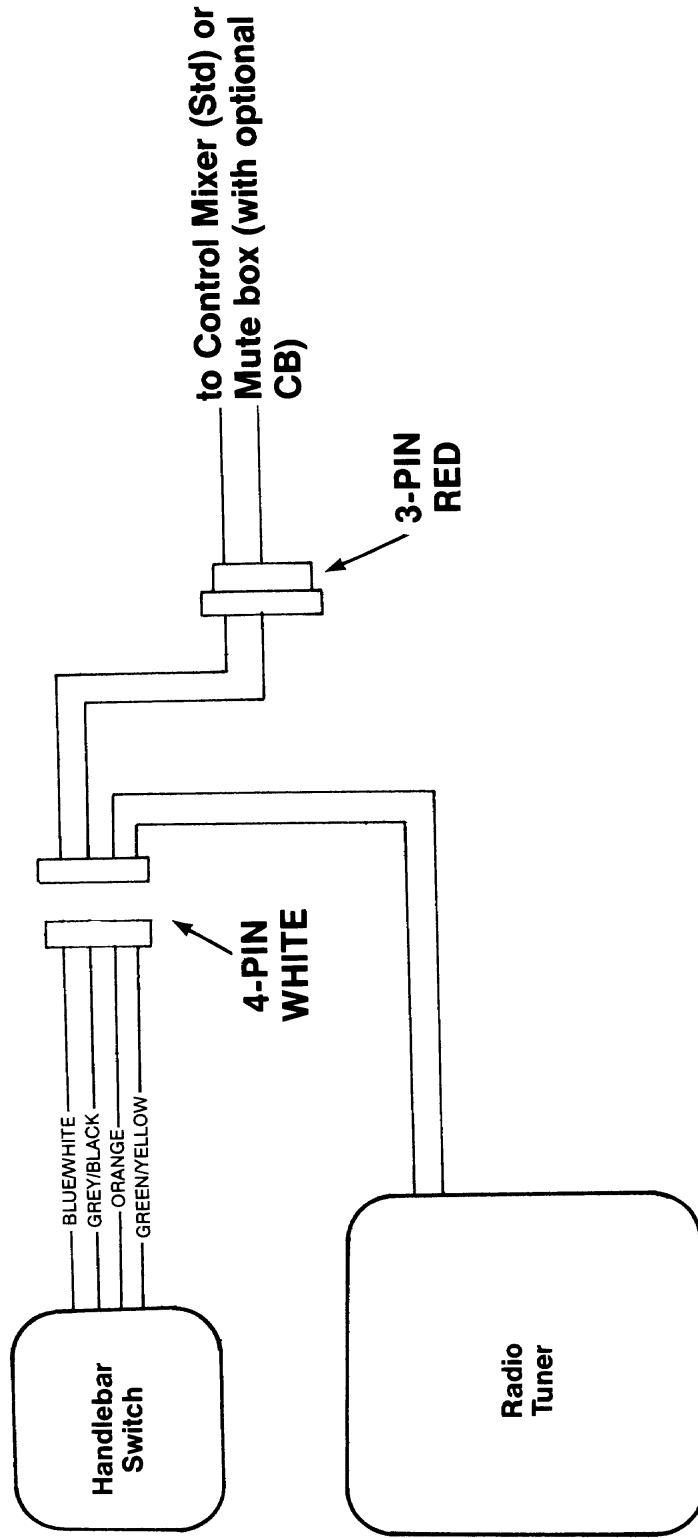

Radio Tuner Test #3

Radio Tuner Output To Radio Display

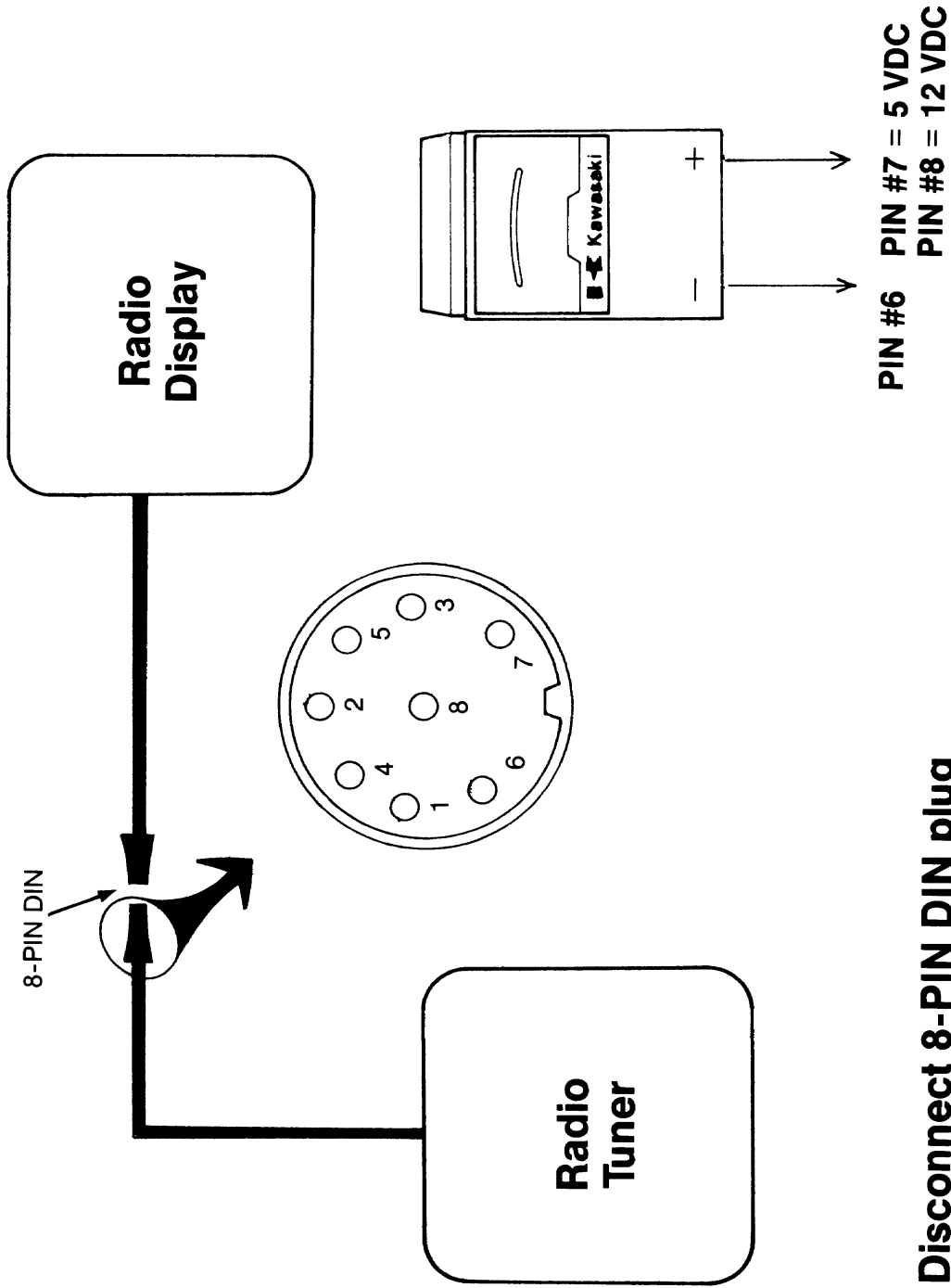

- Disconnect 8-PIN DIN plug
- Turn key to ACC
- Meter should indicate as follows:

Antenna Test #1

Radio Antenna Circuit

- Disconnect the Antenna Cable as shown
- Meter should indicate as follows:

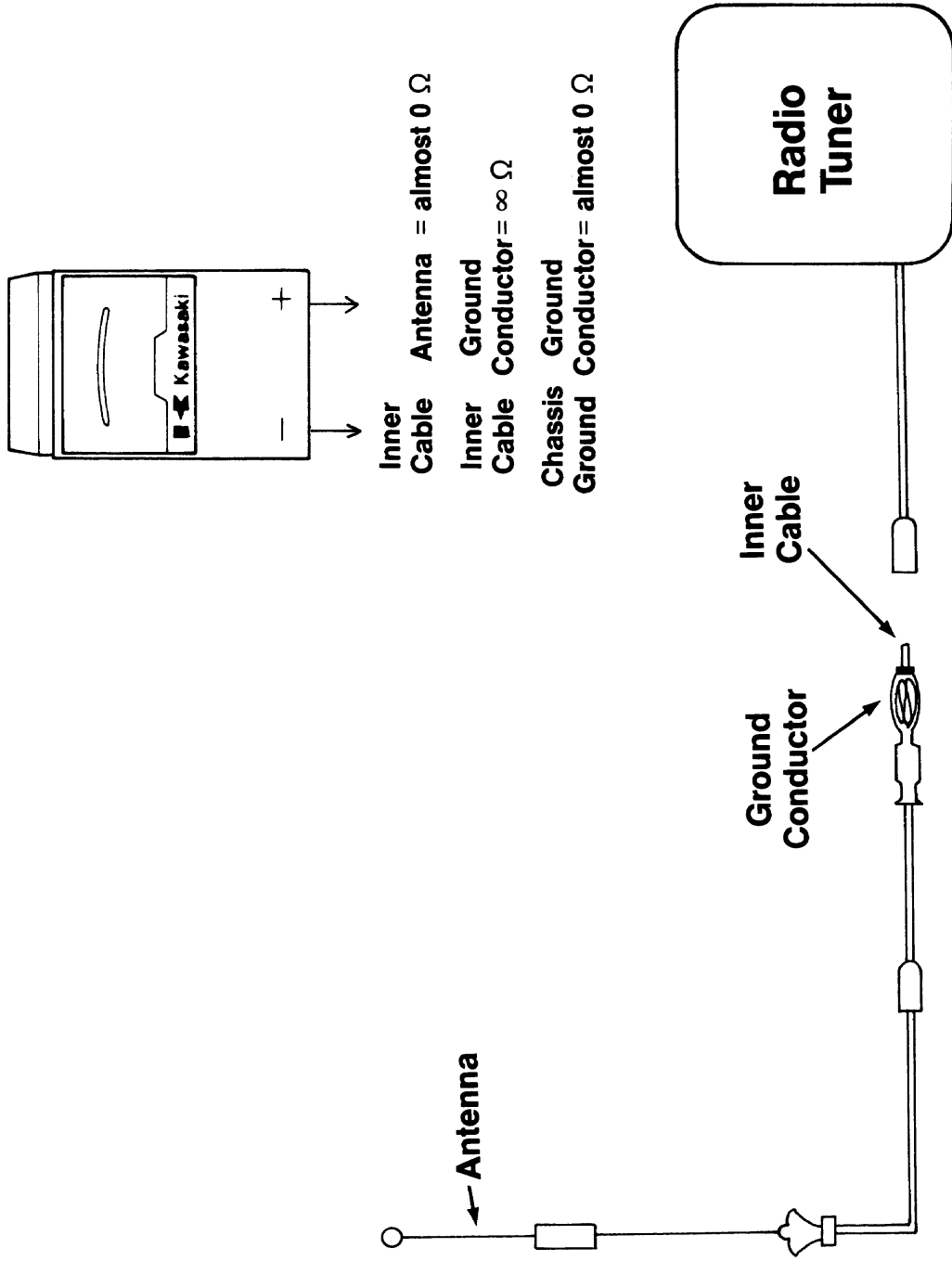

Radio Memory Malfunction

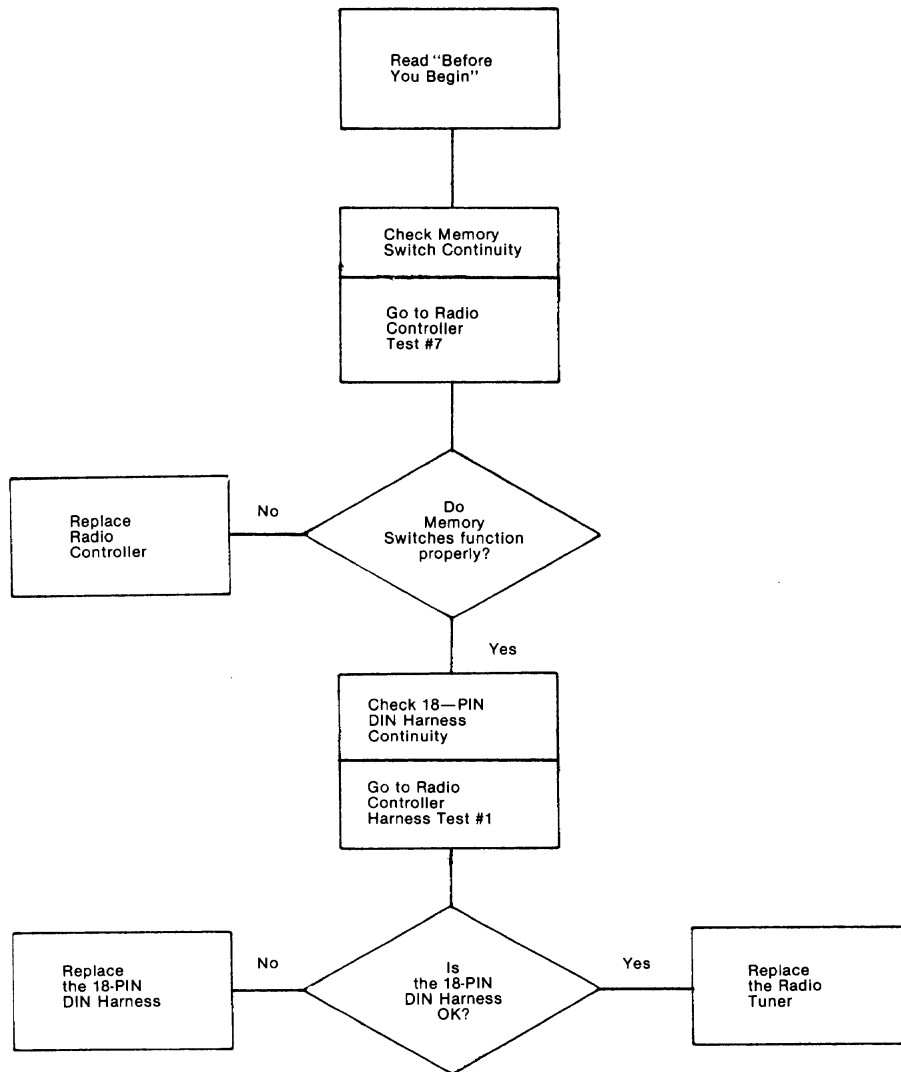

Radio Controller Test #7

Memory Switch Continuity

- Remove the Radio Controller
- Set an ohmmeter to the $\times 1\Omega$ position
- Attach the NEGATIVE meter lead as shown
- One at a time, connect the POSITIVE meter lead to the pins labeled M1, M2, M3, and M4
- When the corresponding MEMORY TUNING button (1, 2, 3, or 4) is depressed, the meter should indicate almost 0Ω
- When the corresponding MEMORY TUNING button is released the meter should indicate $\infty\Omega$

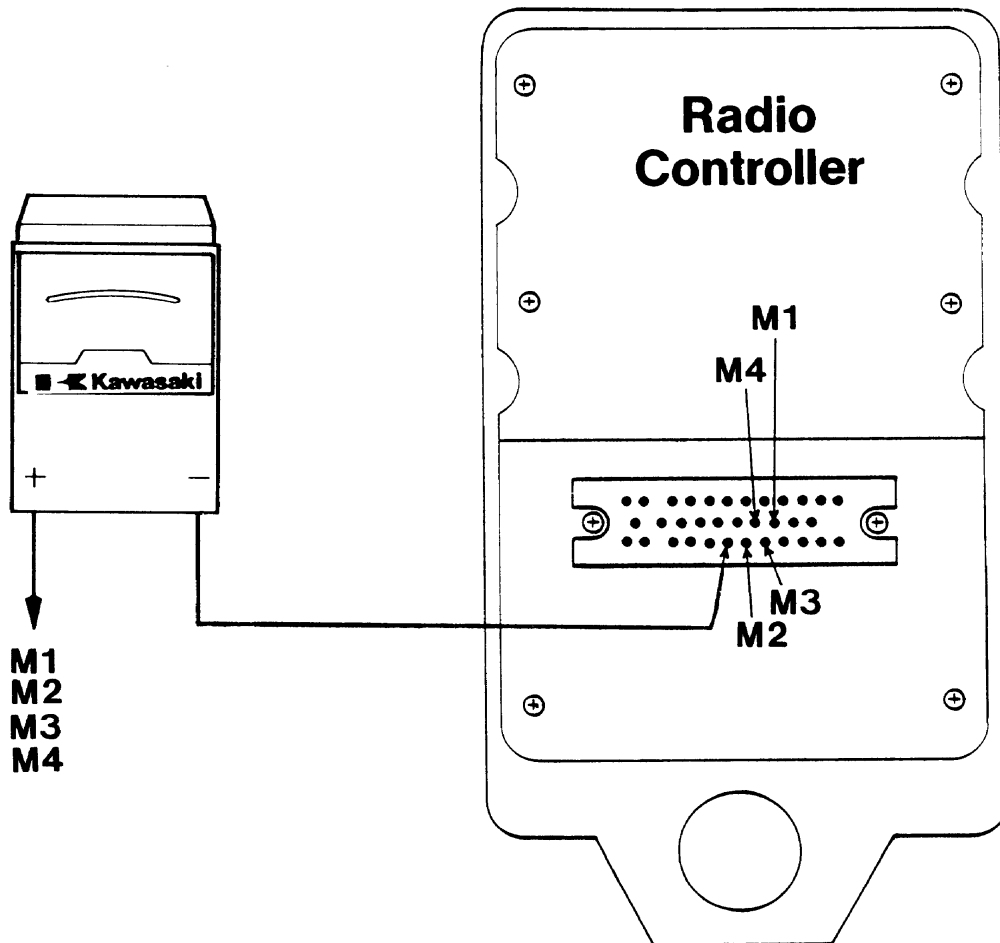

Radio Controller Harness Test #1

18 PIN DIN Harness Continuity

- Remove the Radio Controller and Controller Case
- Disconnect the 18-PIN DIN plug
- Set a multimeter to the x 1 Ω scale
- Connect meter leads to the corresponding pins in the DIN plug and the Radio Controller case plug
- The meter should indicate almost 0 Ω

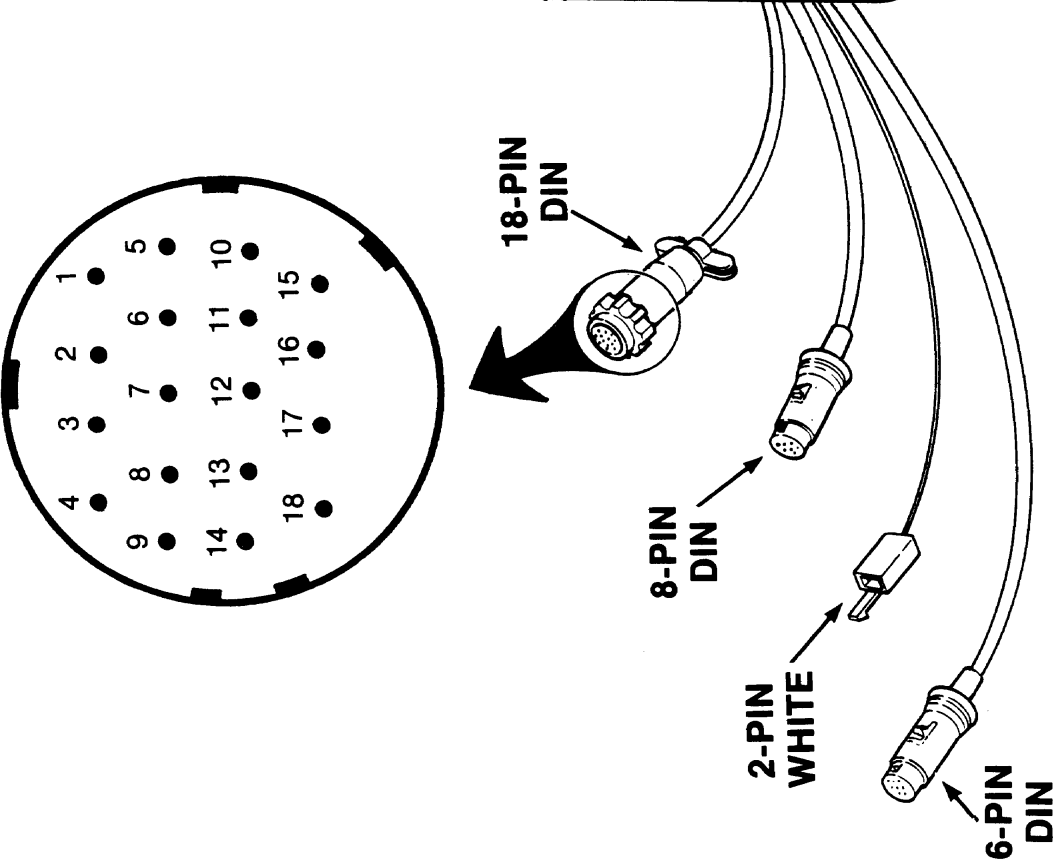
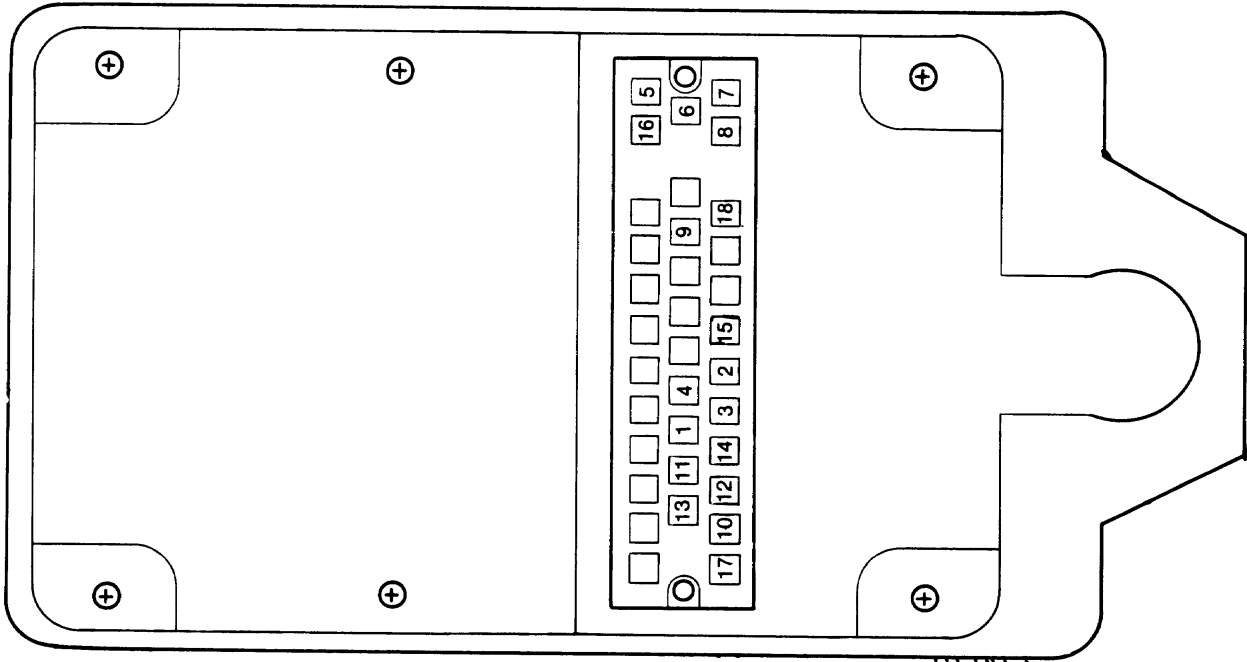

Intercom Difficulty

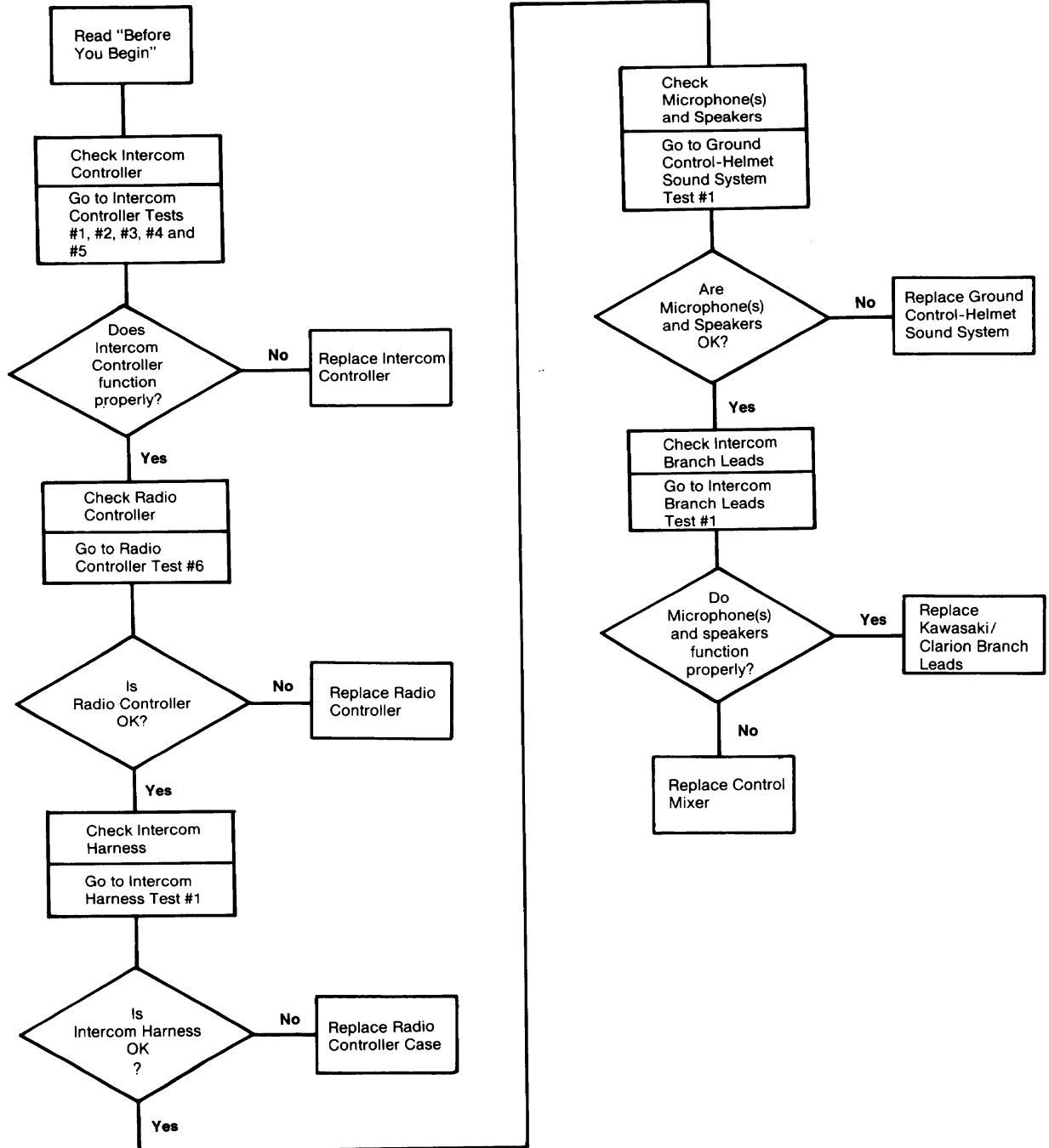

Intercom Controller Test #1

Volume Control

- Remove the Intercom Controller
- Set a multimeter to the x 1K Ω scale
- Connect the meter leads as shown
- With the OFF/VOLUME knob in the OFF position, the meter should indicate almost 0 Ω
- With the OFF/VOLUME knob in the FULL RIGHT position, the meter should indicate about 20K Ω

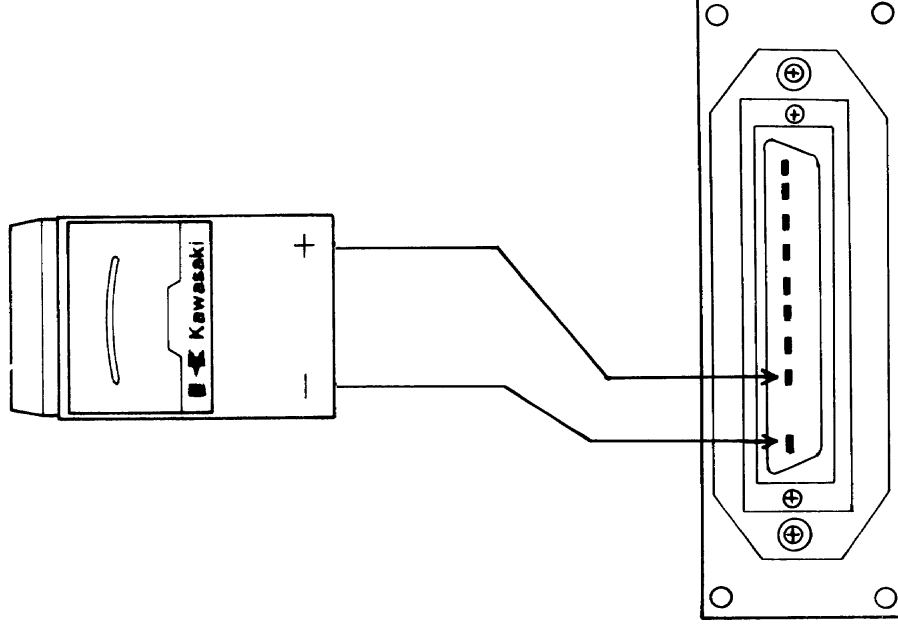

Intercom Controller Test #2

Speaker Switch

- Remove the Intercom Controller
- Set a multimeter to the x 1K Ω scale
- Connect the meter leads as shown
- With the SP/MUTE knob in the FULL LEFT position, the meter should indicate $\infty \Omega$
- With the SP/MUTE knob in the FULL RIGHT position, the meter should indicate almost 0 Ω

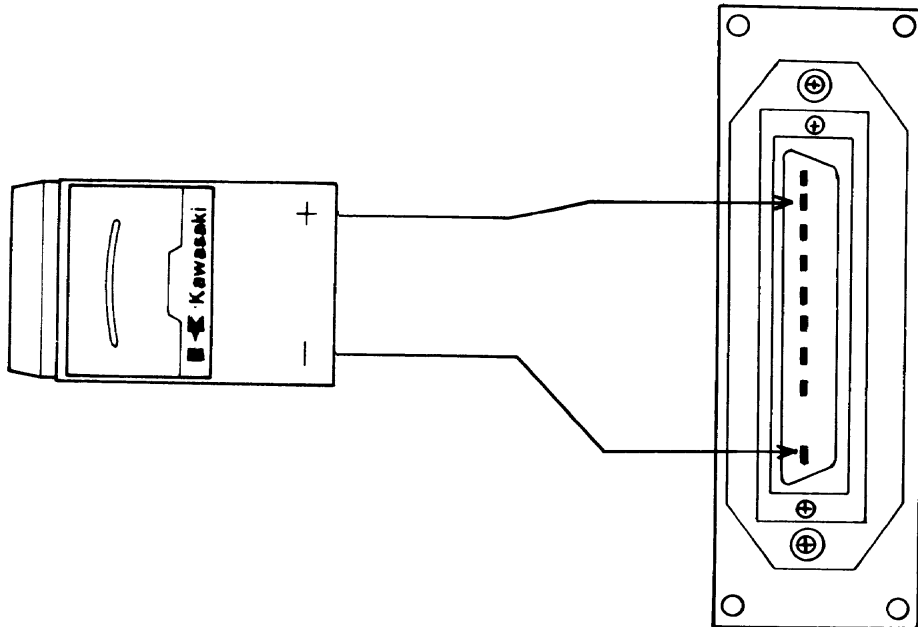

Intercom Controller Test #3

Mute Control

- Remove the Intercom Controller
- Set a multimeter to the x 1K Ω scale
- Connect the meter leads as shown
- With the SP/MUTE knob in the FULL LEFT position, the meter should indicate almost 0 Ω
- With the SP/MUTE knob in the FULL RIGHT position, the meter should indicate about 20K Ω

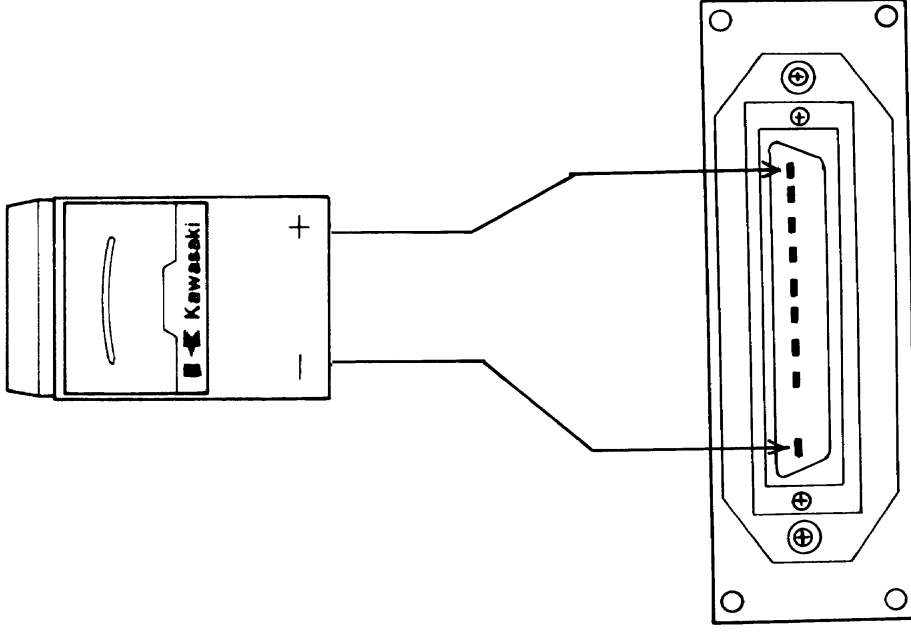

Intercom Controller Test #4

On/Off Switch

- Remove the Intercom Controller
- Set a multimeter to the x 1K Ω scale
- Connect the meter leads as shown
- With the OFF/VOLUME switch in the OFF position, the meter should indicate $\infty \Omega$
- With the OFF/VOLUME switch in any ON position, the meter should indicate almost 0 Ω

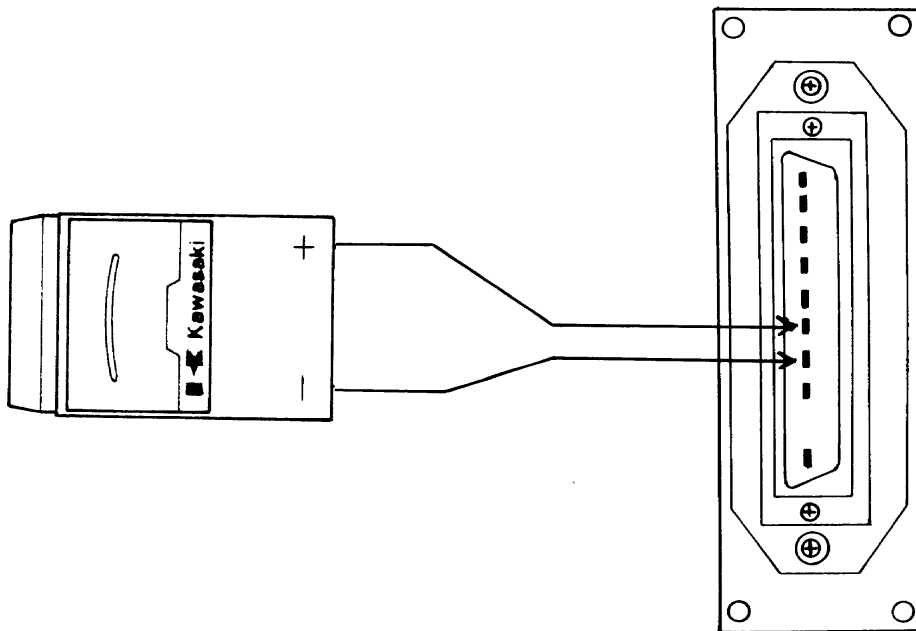

Intercom Controller Test #5 Light

- Remove the Intercom Controller
- Set a multimeter to the x 10 Ω scale
- Connect the meter leads as shown
- The meter should indicate about 100 Ω

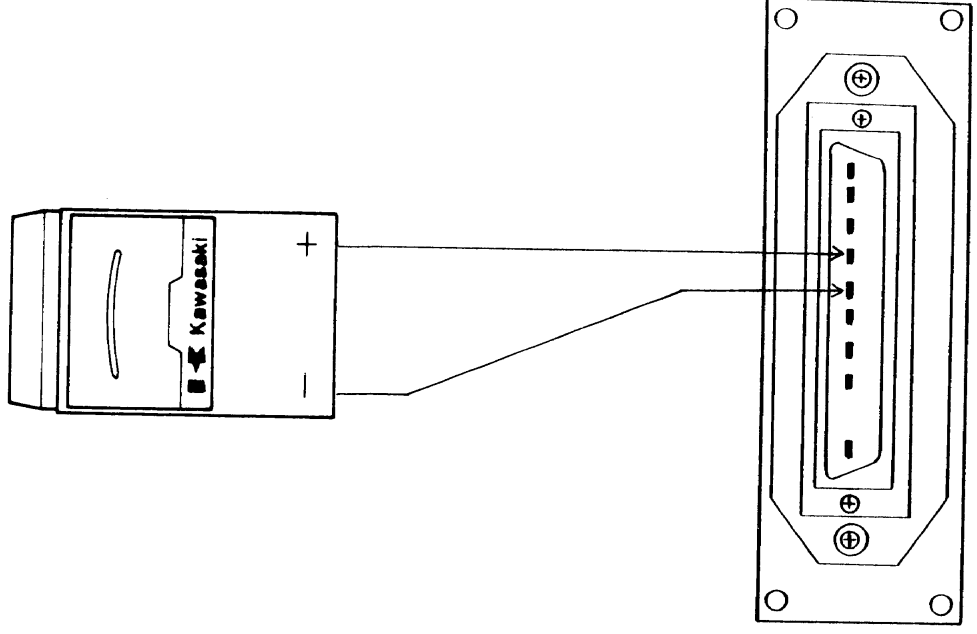

Radio Controller Test #6 Intercom Circuitry Continuity

- Remove Radio Controller
- Remove Intercom Controller from Radio Controller
- Set a multimeter to the x 1 Ω scale
- Connect the meter leads to the corresponding pins in the top and the bottom of the Radio Controller
- The meter should indicate almost 0 Ω

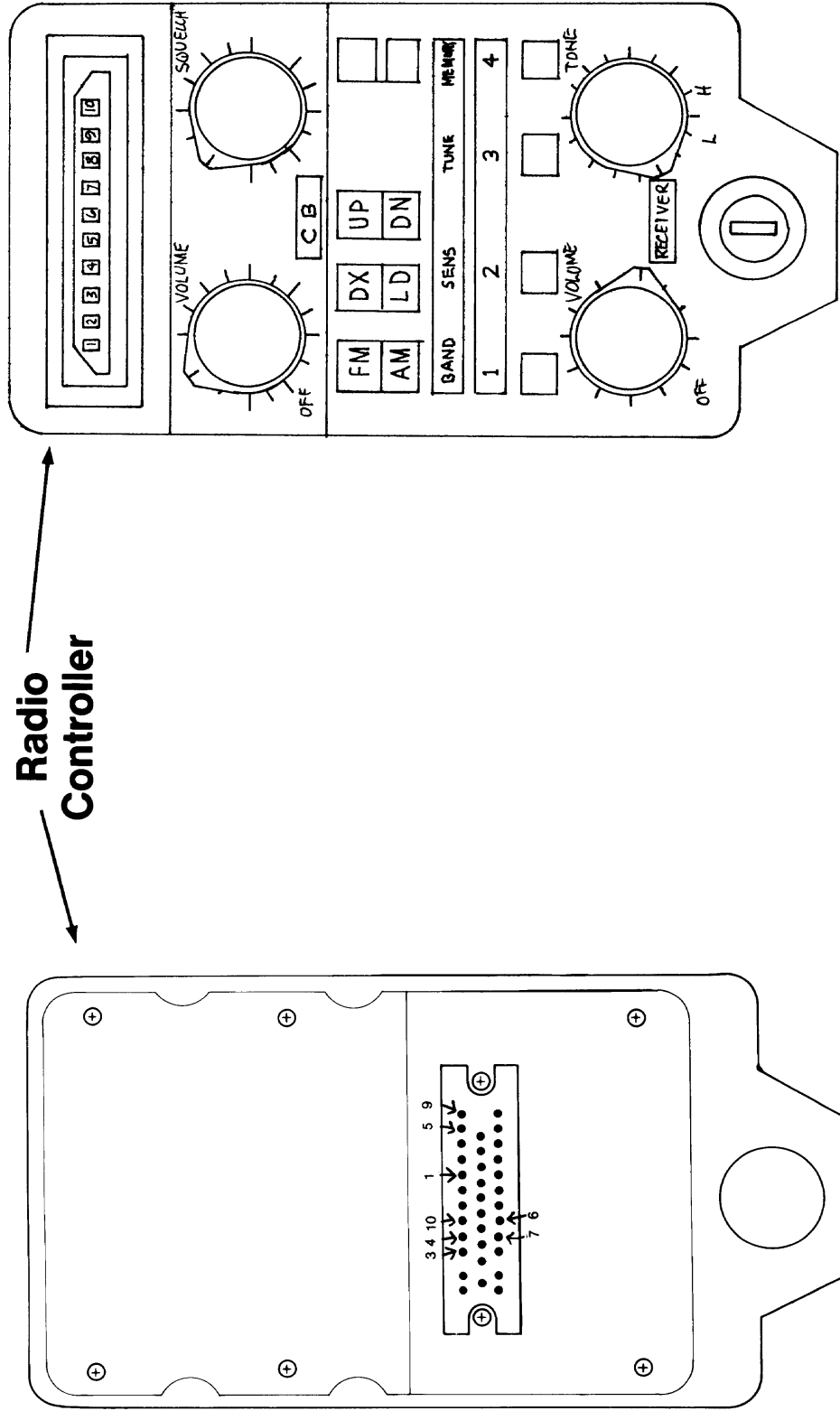

Intercom Harness Test #1

6 PIN DIN Harness Continuity

- Remove the Radio Controller
- Disconnect the INT COM plug (6-PIN DIN) from the Control Mixer
- Set a multimeter to the x 1 Ω scale
- Connect the meter leads to the corresponding pins in the DIN plug and the Intercom Controller case plug
- The meter should indicate almost 0 Ω

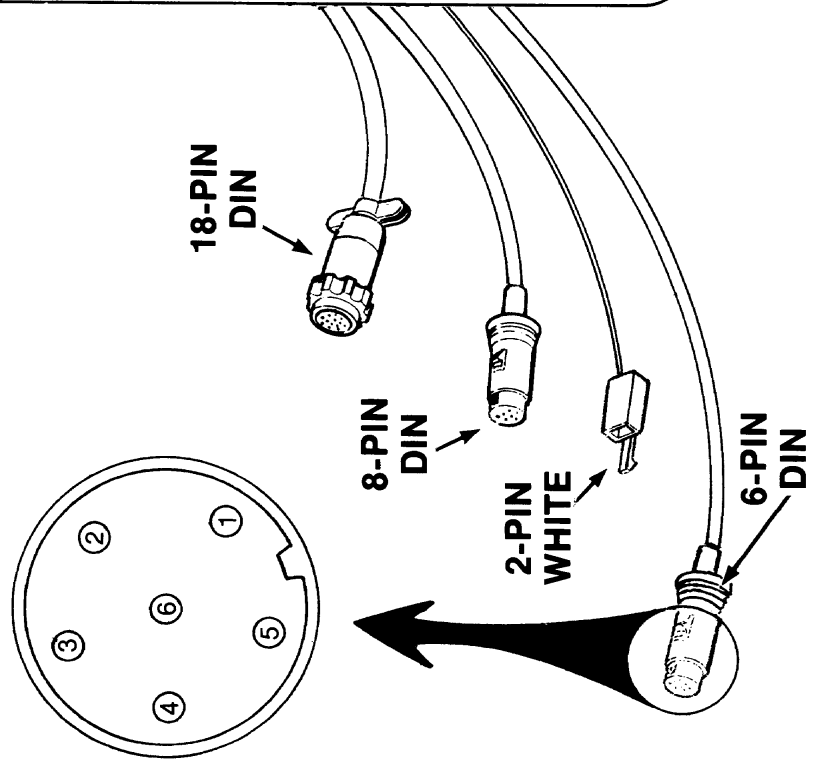
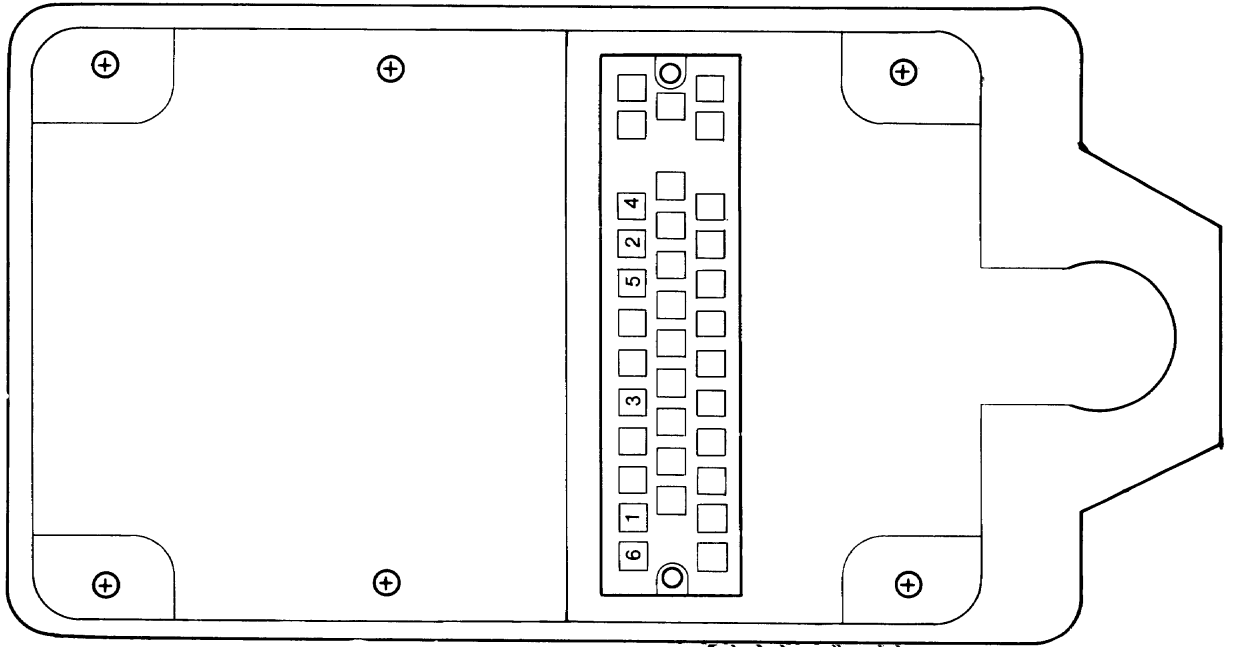

Ground Control-Helmet Sound System Test #1 Microphone & Speakers Test

- Set a multimeter to the appropriate OHMS scale
- Meter should indicate as follows:

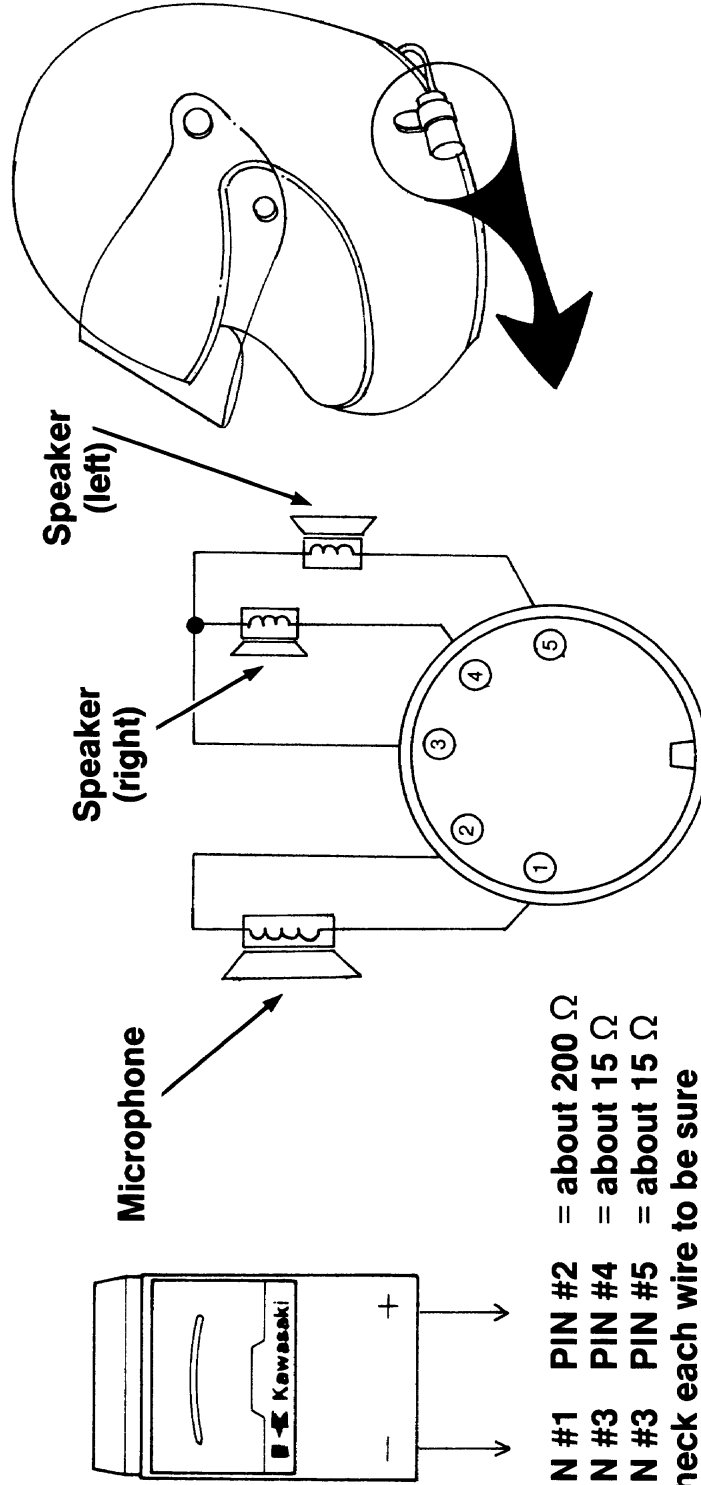

PIN #1 PIN #2 = about 200 Ω
PIN #3 PIN #4 = about 15 Ω
PIN #3 PIN #5 = about 15 Ω
Check each wire to be sure
it is not shorted to
other wires (pins 4-5 should
indicate about 30 Ω)

Intercom Branch Leads Test #1

Control Mixer Output to Headsets

Test Connections

- Connect the Test Harness as shown
- Turn the key to ACC
- Test the operation of speakers and microphone in each helmet

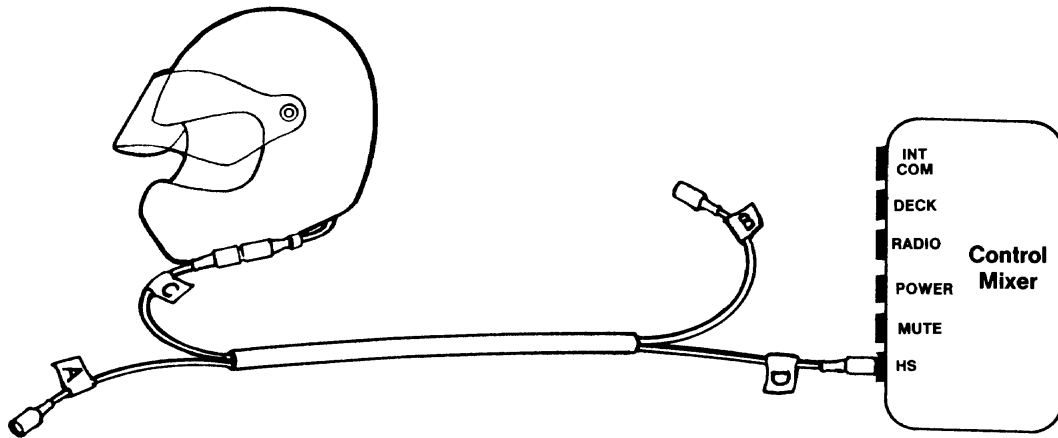

Standard Connections

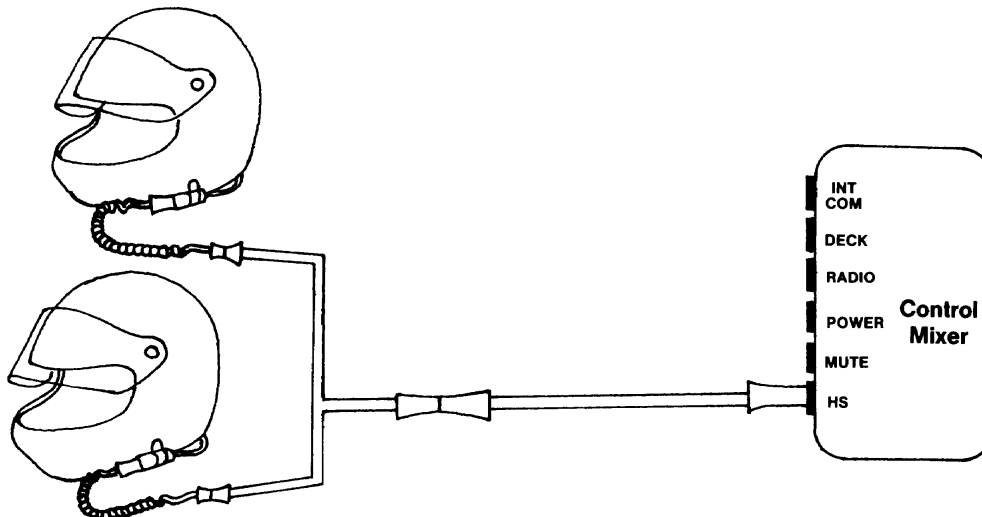

No Sound From CB (only)

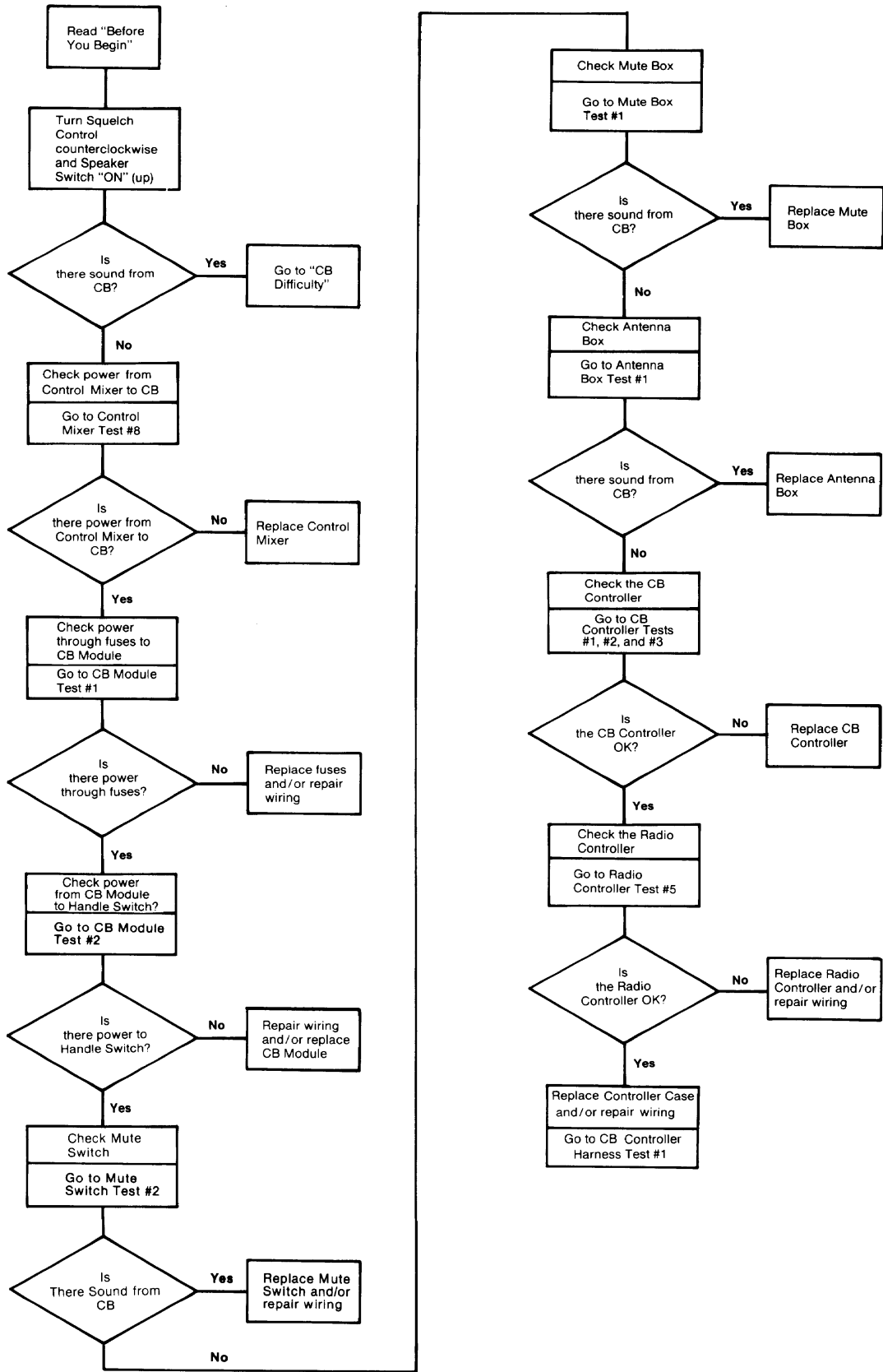

Control Mixer Test #8

Power From Control Mixer To CB

- Turn key to ACC
- Turn CB ON
- Meter should indicate 12 VDC

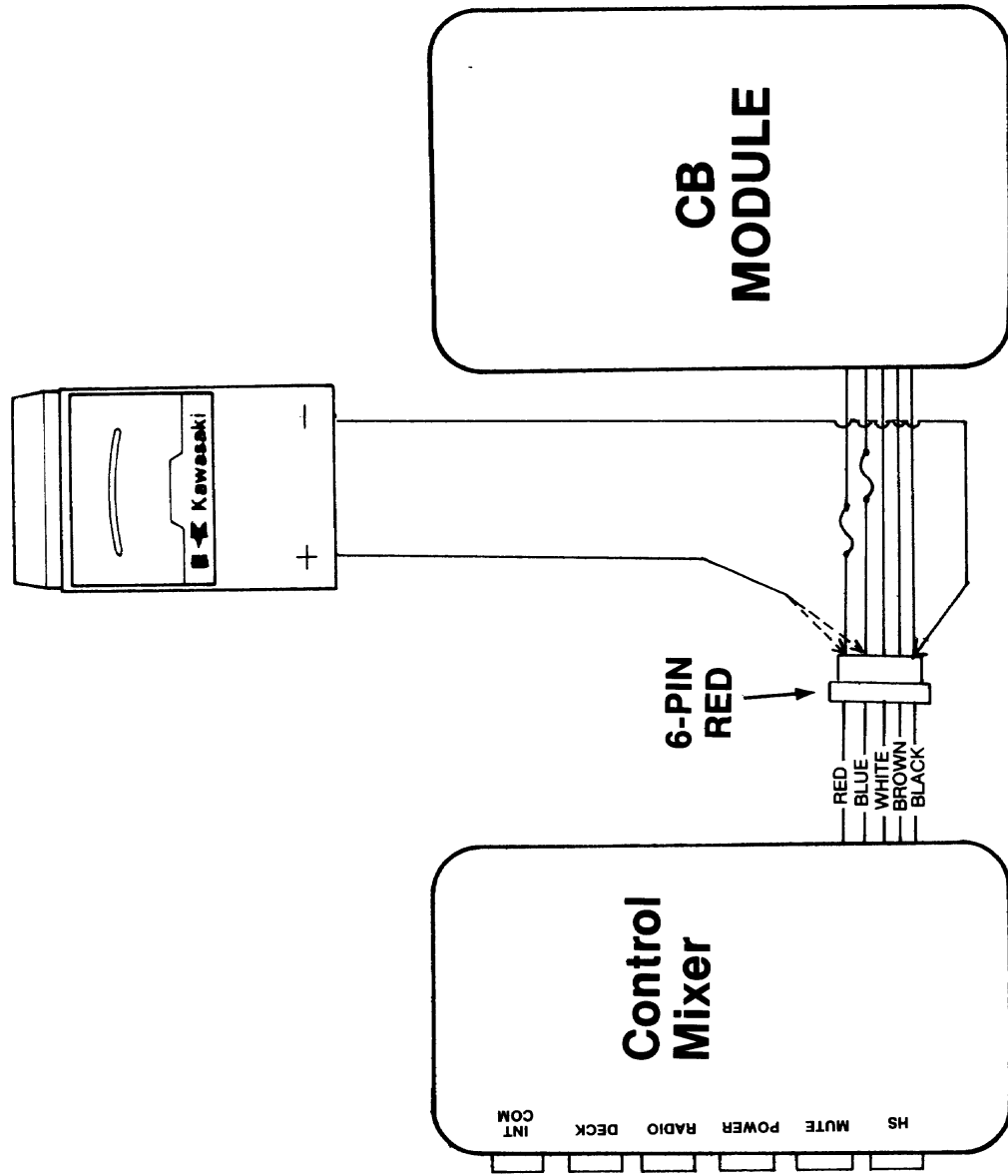

CB Module Test #1

Power Through Fuses To CB Module

- Turn key to ACC
- Turn CB ON
- Meter should indicate 12 VDC

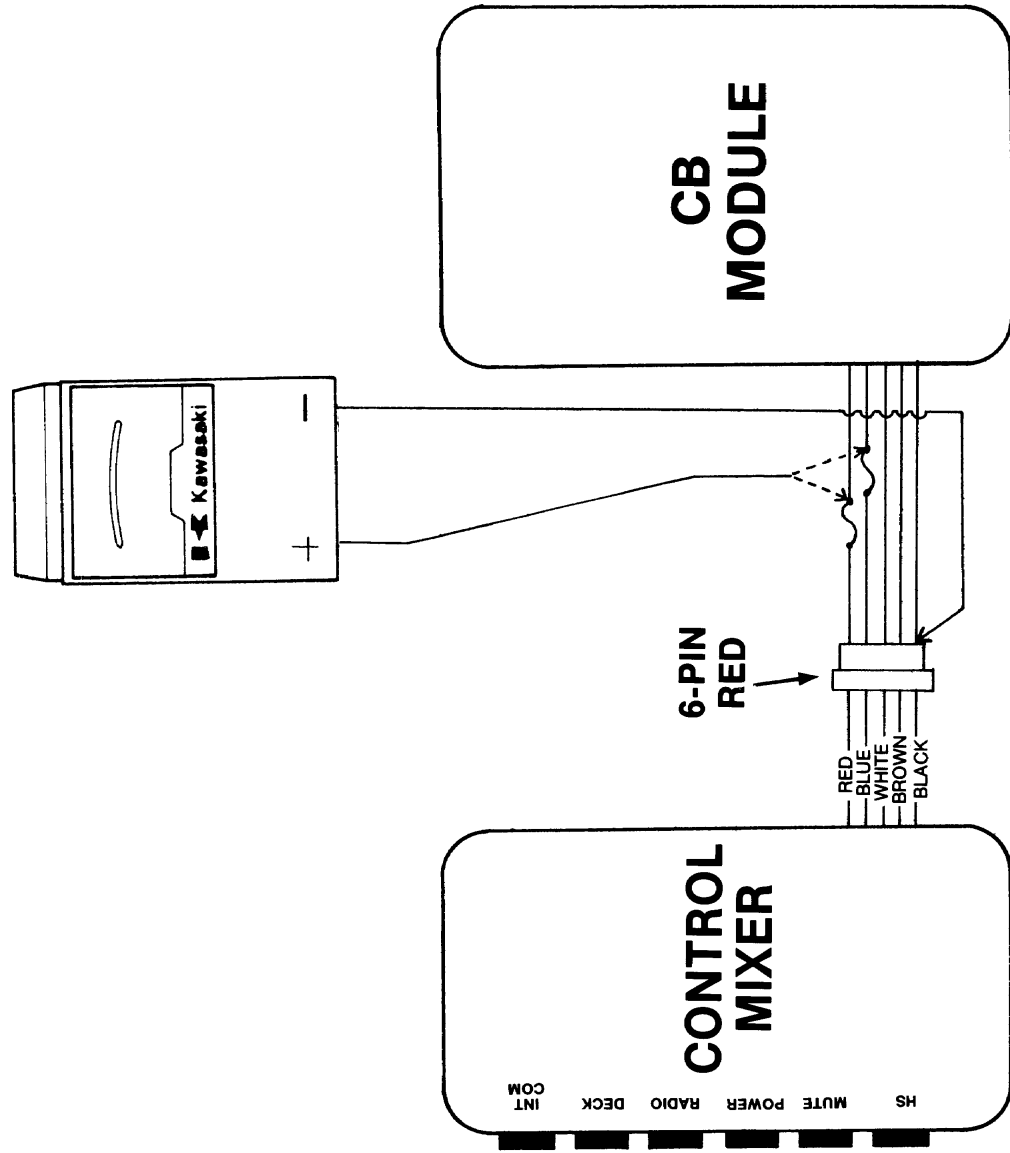

CB Module Test #2.

Power From CB Module To Handle Switch

- Turn key to ACC
- Turn CB ON
- Meter should indicate 12 VDC

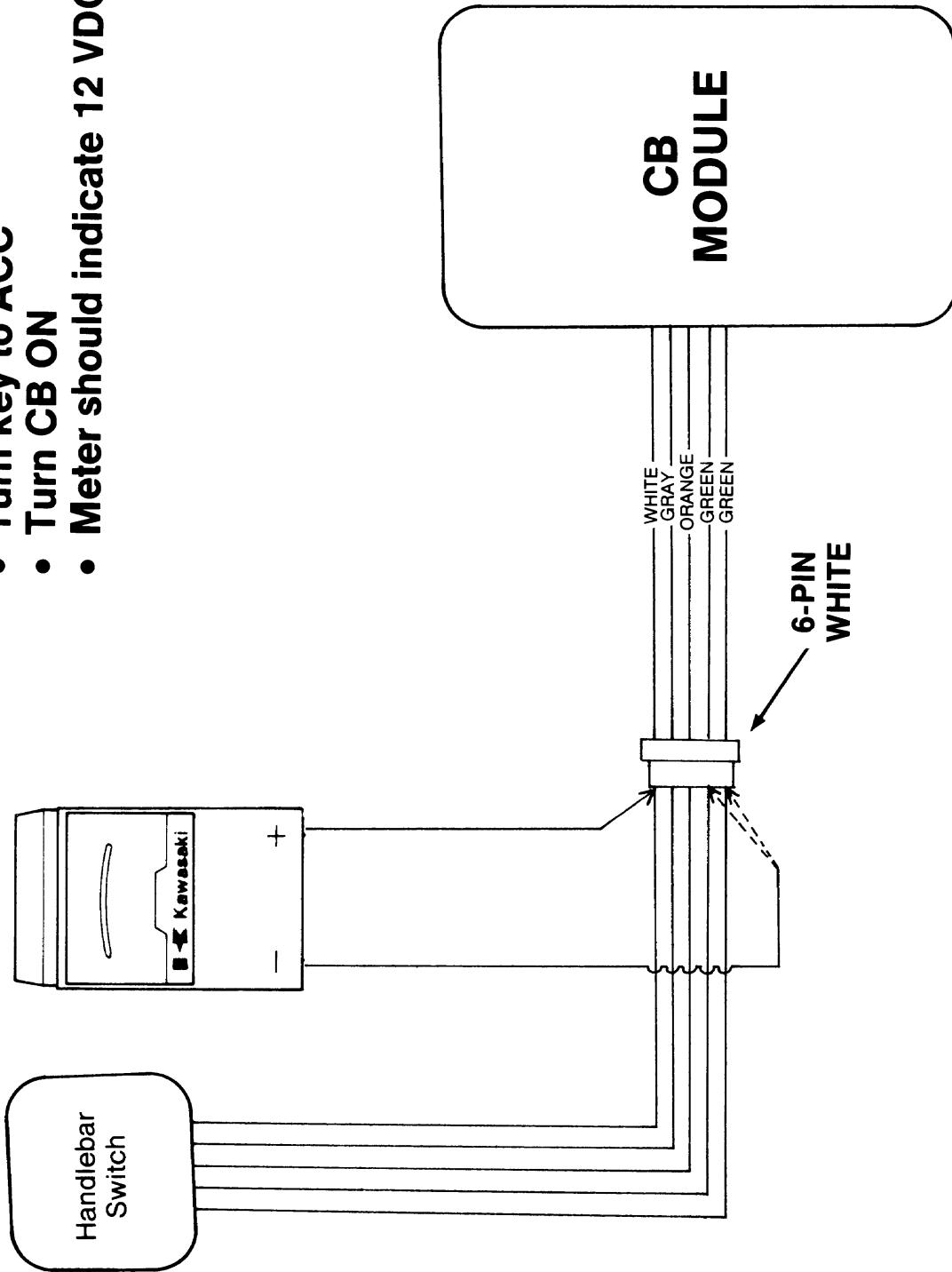

Mute Switch Test #2

Disconnect Mute Switch From Mute Box

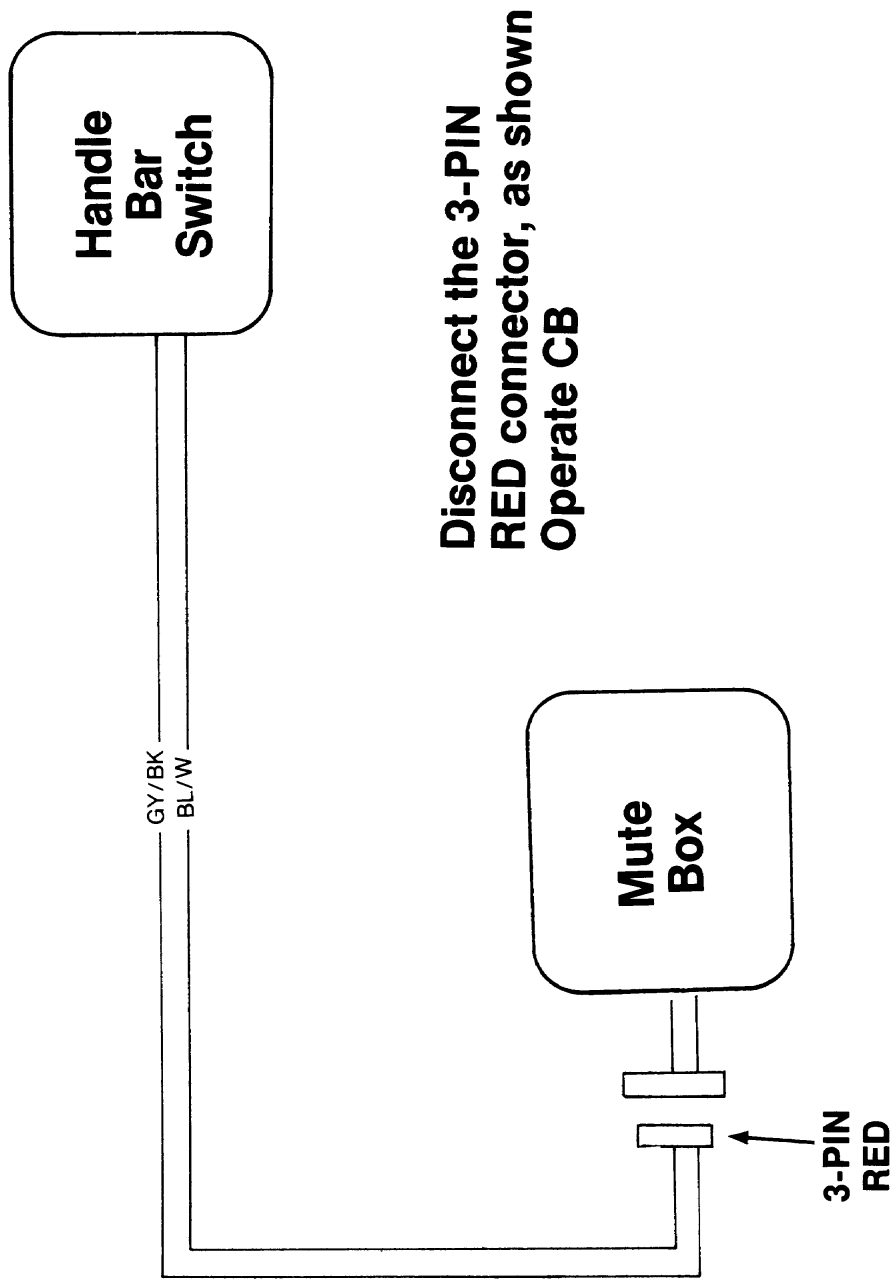

Mute Box Test #1

CB Module Output to Control Mixer

Test Connection

- Disconnect Mute Box
- Connect Test Harness as shown

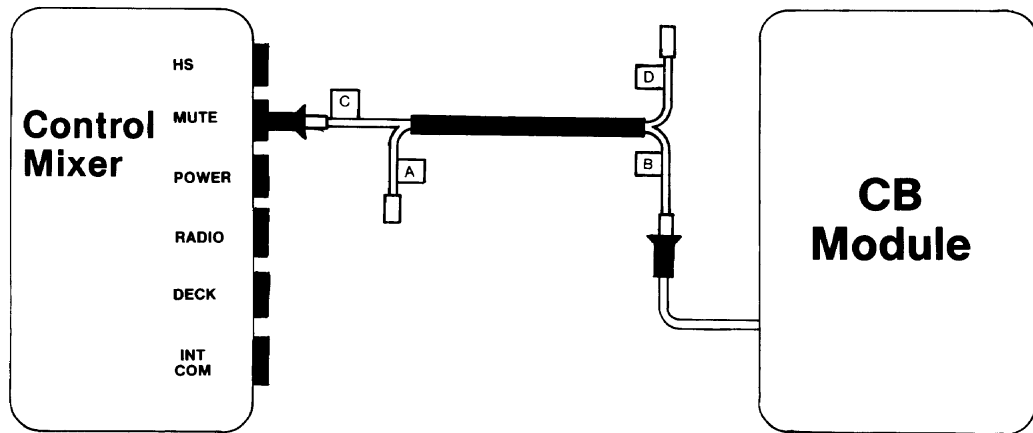
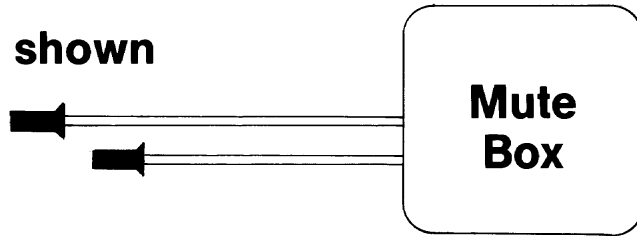

Standard Connection

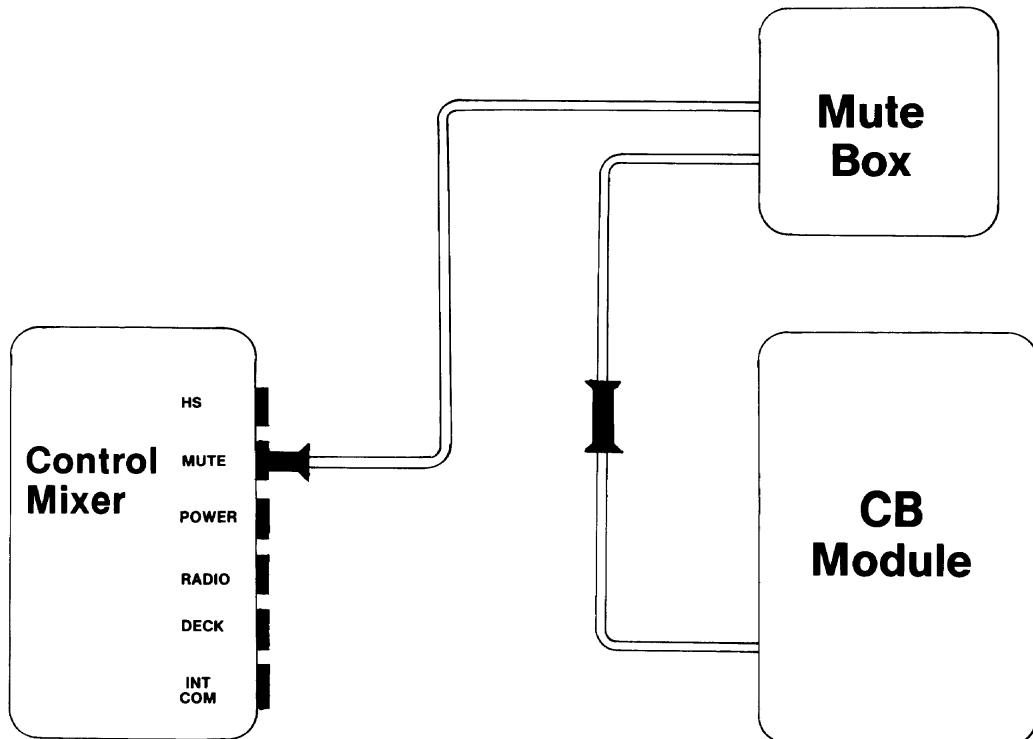

Antenna Box Test #1 CB Circuit Bypass

Standard Connections

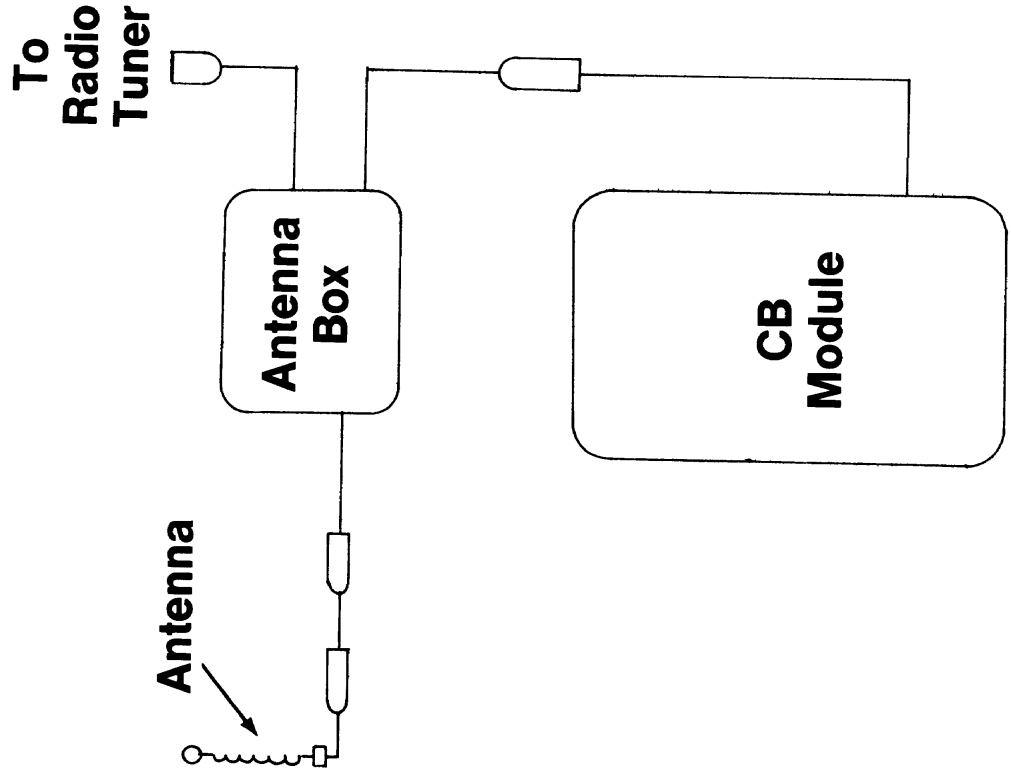

Test Connections

- Disconnect Antenna Cables from Antenna Box as shown
- Connect Test Cable as shown
- Operate CB

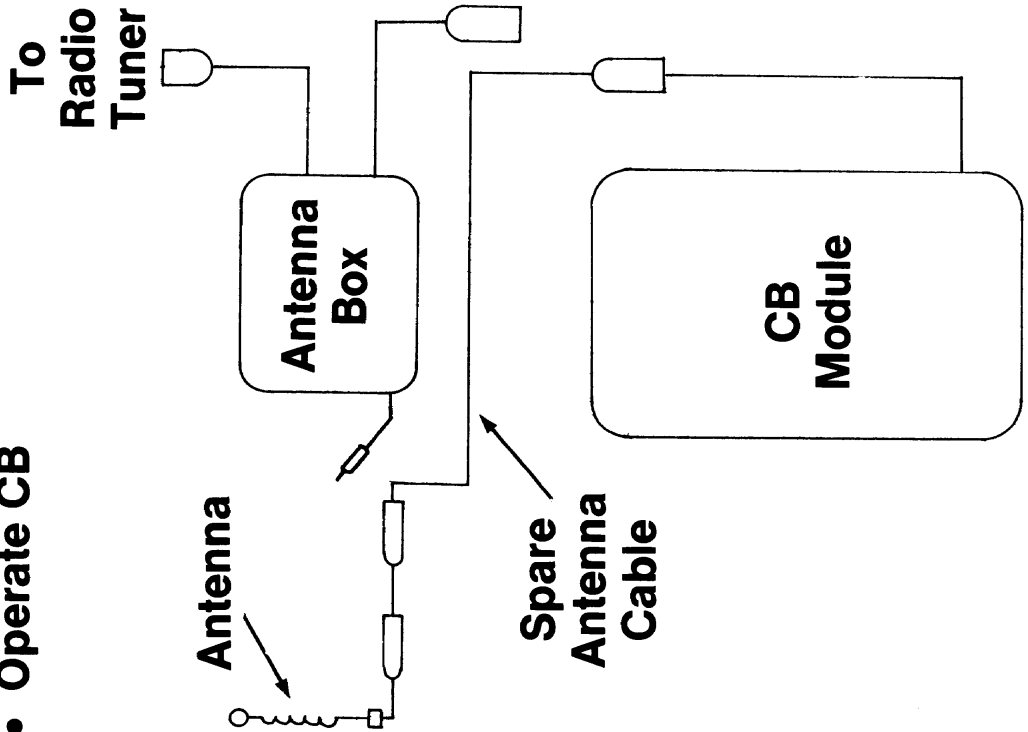

CB Controller Test #1

On/Off Switch

- Remove the CB Controller
- Set a multimeter to the x 1K Ω scale
- Connect the meter leads as shown
- With the OFF/VOLUME knob in the OFF position, the meter should indicate $\infty \Omega$
- With the OFF/VOLUME knob in any ON position, the meter should indicate almost 0 Ω

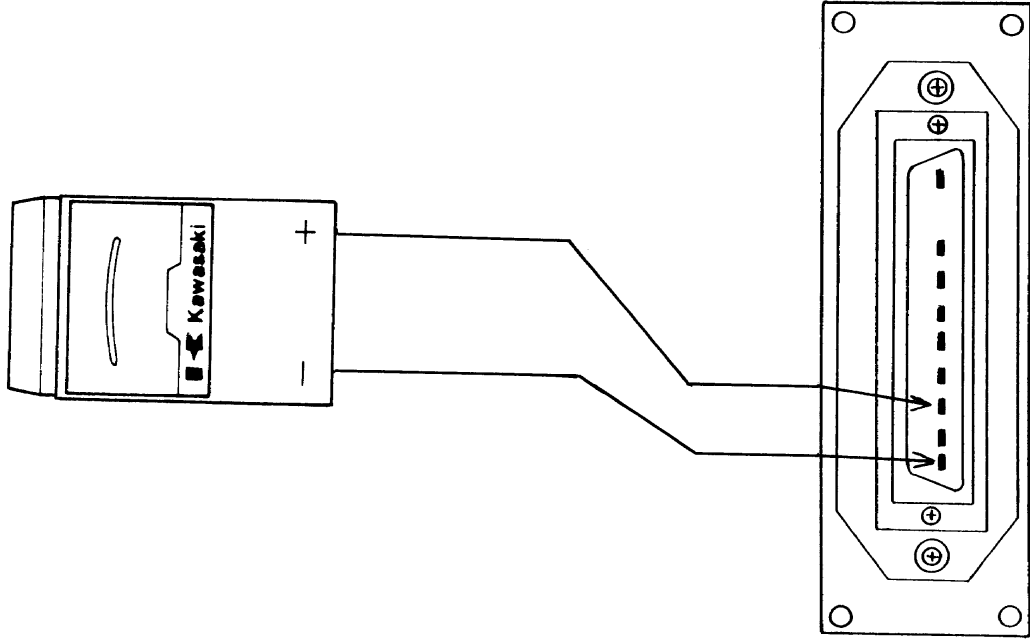

CB Controller Test #2

Volume Control

- Remove the CB Controller
- Set the multimeter to the x 1K Ω scale
- Connect the meter leads as shown
- With the OFF/VOLUME knob in the OFF position, the meter should indicate almost 0 Ω
- With the OFF/VOLUME knob in the FULL RIGHT position, the meter should indicate about 30K Ω

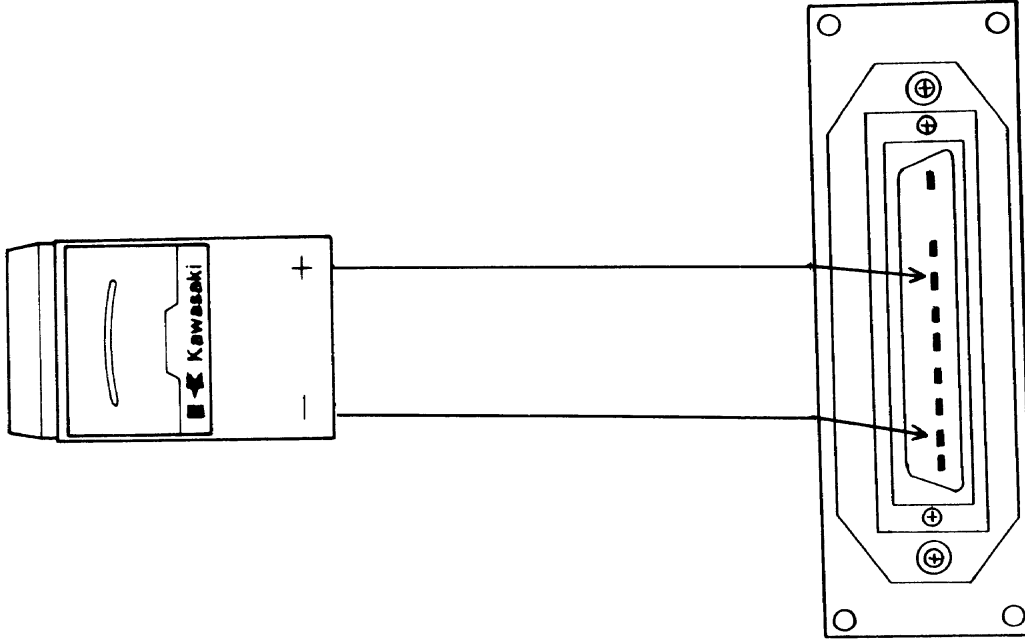

CB Controller Test #3

Squelch Control

- Remove the CB Controller
- Set the multimeter to the x 1K Ω scale
- Connect the meter leads as shown
- With the squelch knob in the FULL LEFT position, the meter should indicate almost 0 Ω
- With the squelch knob in the FULL RIGHT position, the meter should indicate about 6K Ω

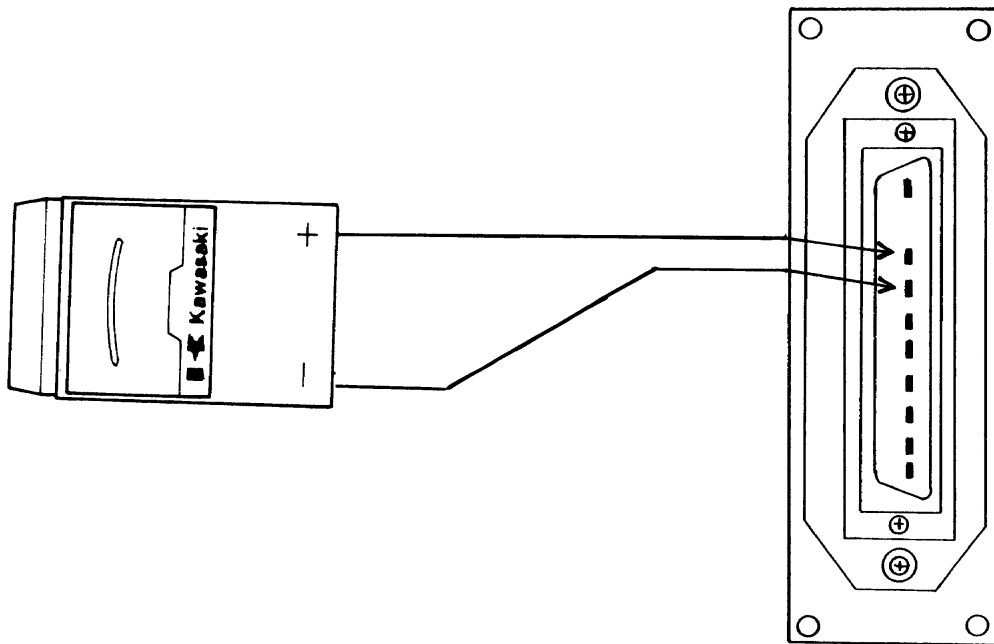

Radio Controller Test #5 CB Circuitry Continuity

- Remove Radio Controller
- Remove CB Controller from Radio Controller
- Set a multimeter to the x 1 Ω scale
- Connect the meter leads to the corresponding pins in the top and the bottom of the Radio Controller
- The meter should indicate almost 0 Ω

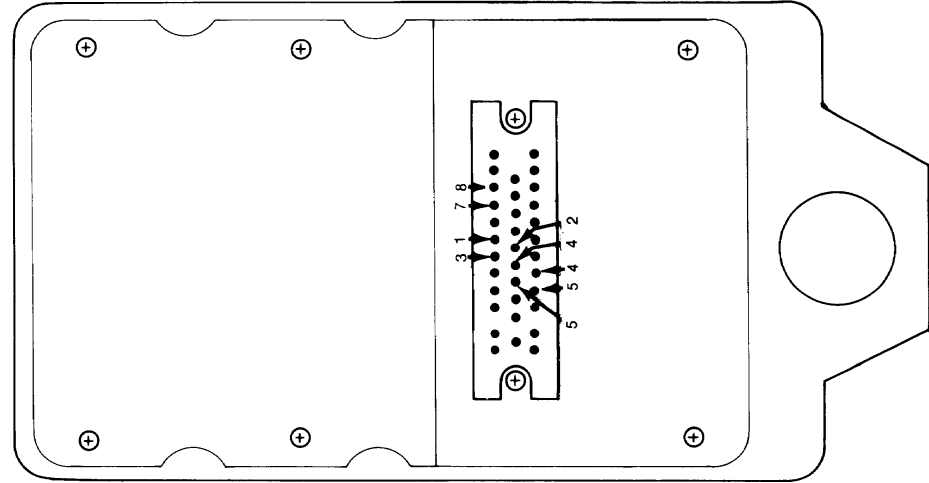

Radio
Controller

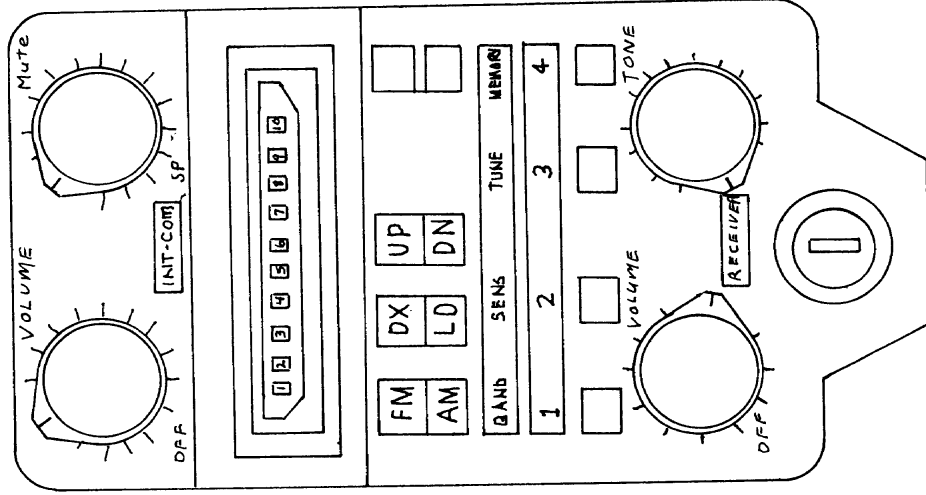

CB Controller Harness Test #1

8 PIN DIN Harness Continuity

- Remove the Radio Controller plug
- Disconnect the 8-PIN DIN
- Set a multimeter to the x 1 Ω scale
- Connect meter leads to the corresponding pins in the DIN and the Radio Controller Case plug
- The meter should indicate almost 0 Ω

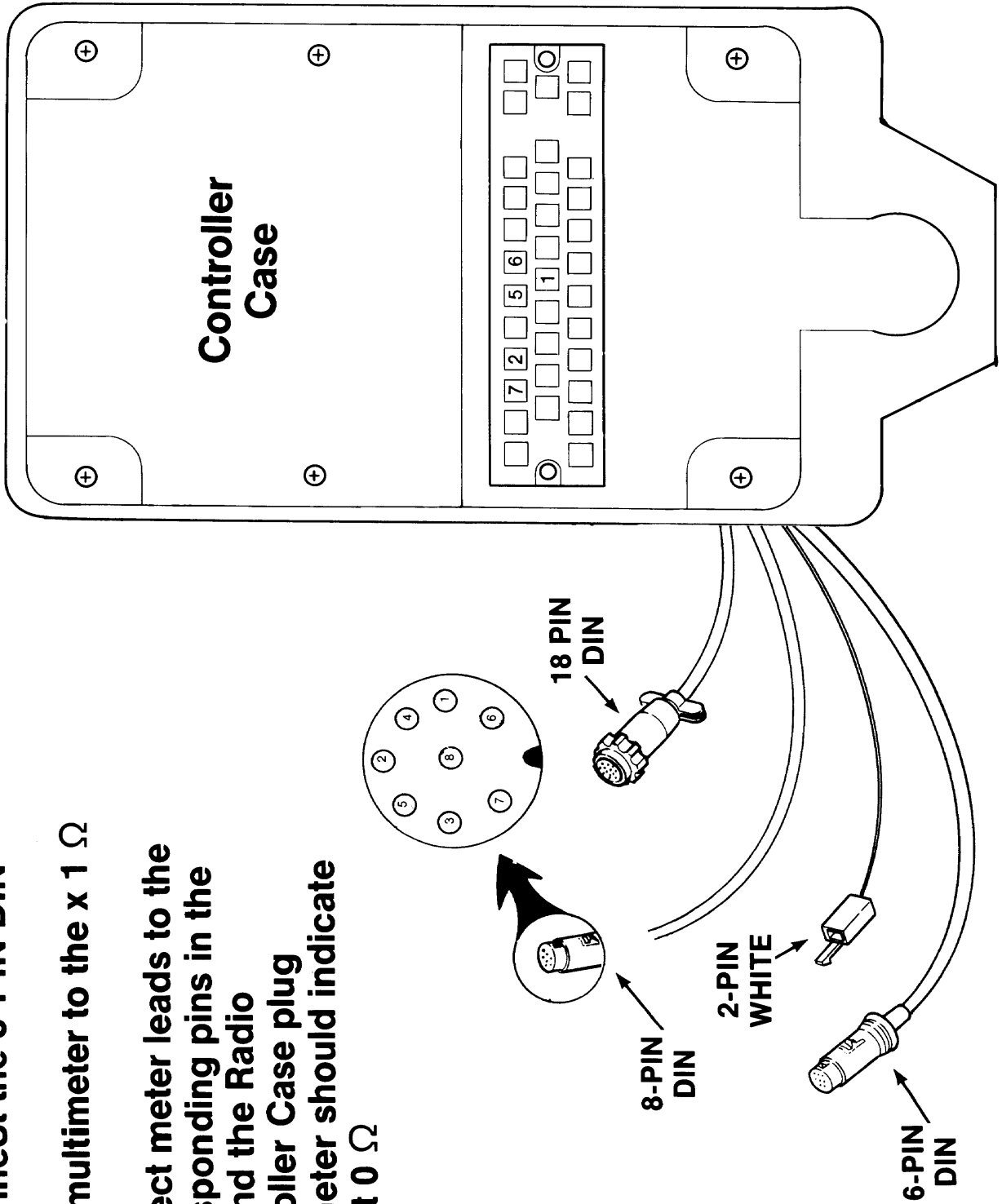

CB Difficulty

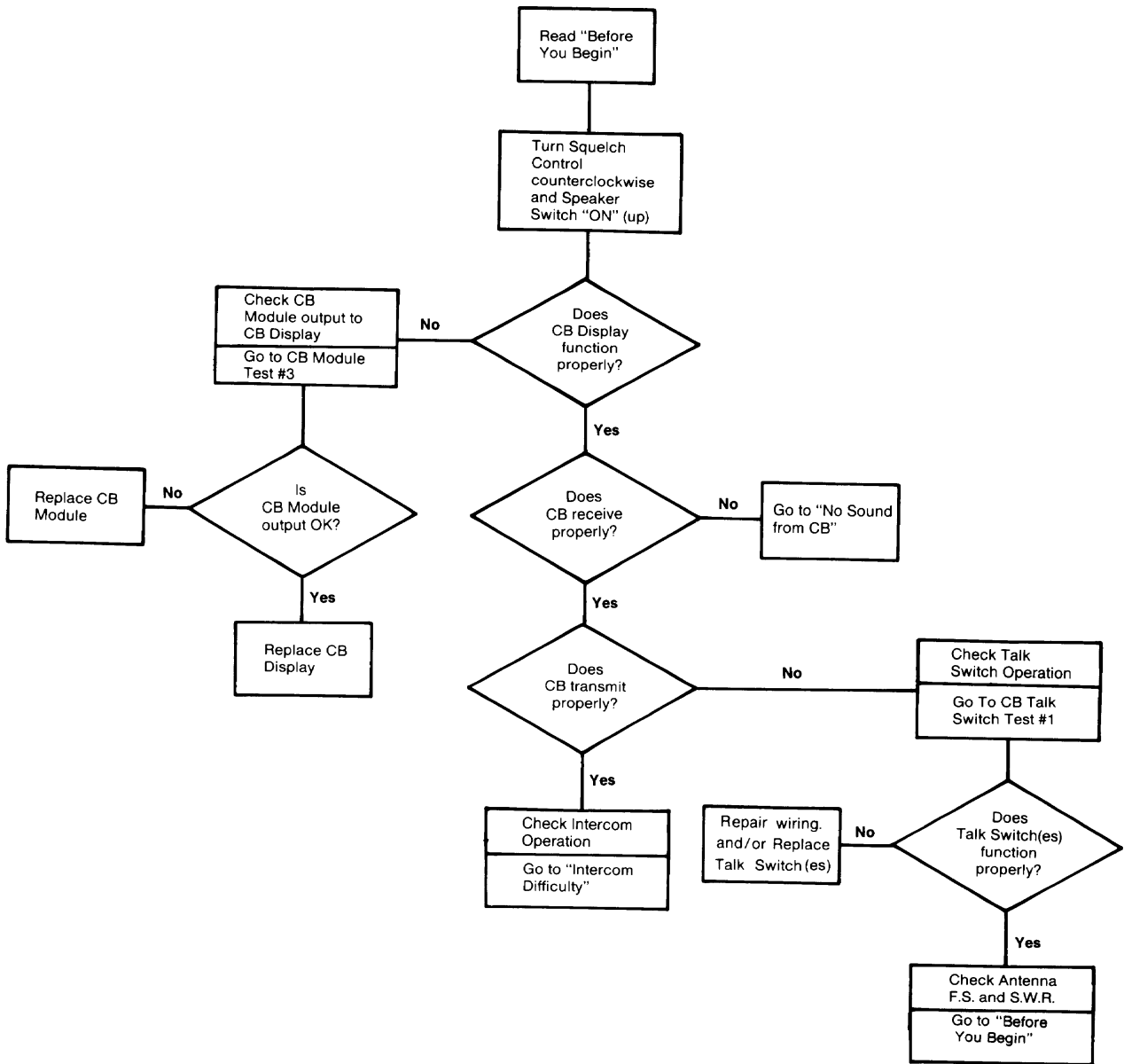

CB Module Test #3

CB Module Output To CB Display

- Disconnect the 8-PIN DIN plug
- Turn key to ACC
- Turn CB ON
- Meter should indicate as follows:

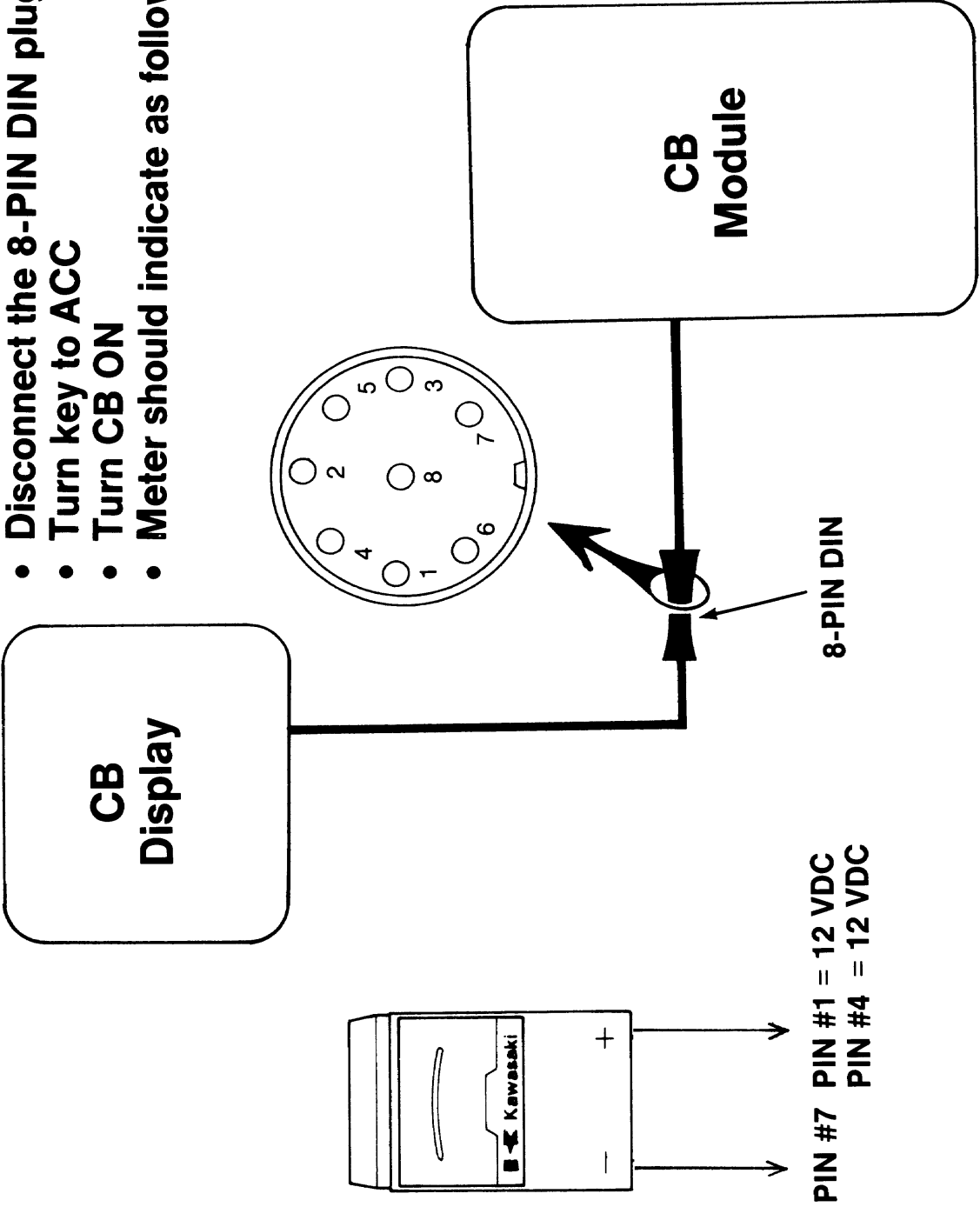

PIN #7 = 12 VDC
PIN #4 = 12 VDC

CB Talk Switch Test #1

Operator and Passenger Talk Switch Operation

- Set a multimeter to the x 1K Ω scale
- Disconnect the 6-PIN WHITE connector and the 2-PIN WHITE connector
- Connect meter leads as shown
- With talk button released, meter should indicate $\infty \Omega$
- With talk button depressed, meter should indicate almost 0 Ω

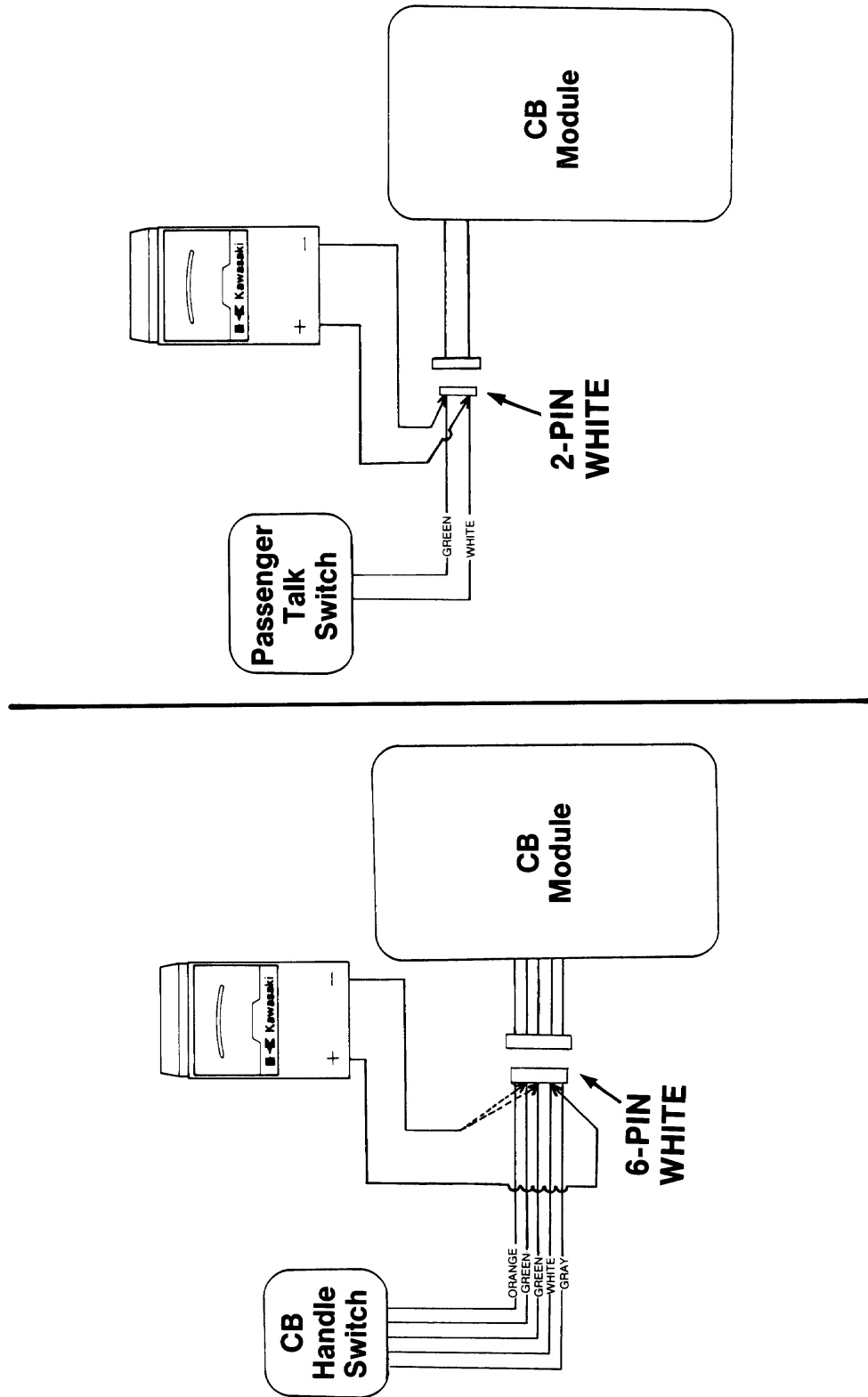

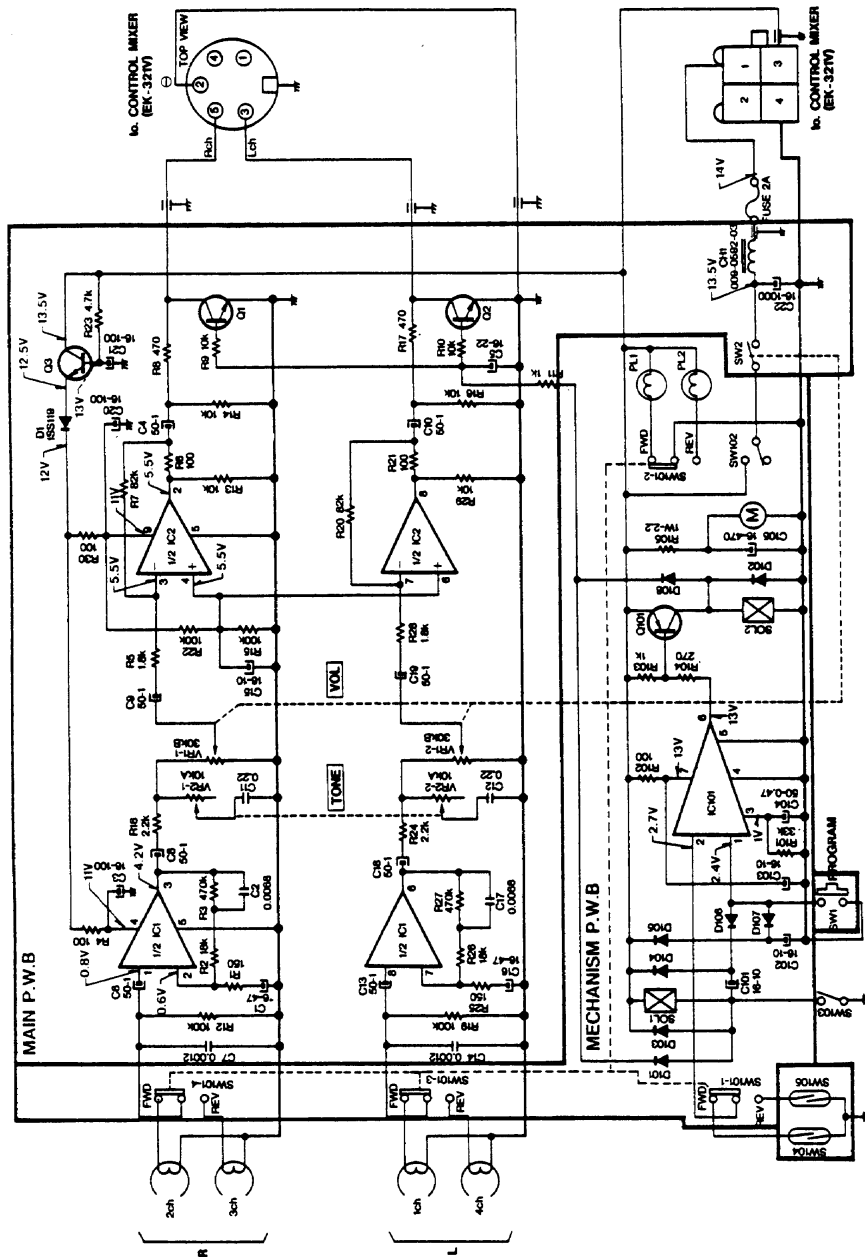

Audio System Power Supply Circuit

12 VDC is available at the 4-PIN BROWN connector:

- At the RED/WHITE wire at all times (clock/memory)
- At the BLACK/WHITE and BLACK wires when they key is in ACC or ON position, and the starter button is released (while the starter becomes positive and the Accessories Relay ground wire polarity becomes positive and the relay is inoperative)

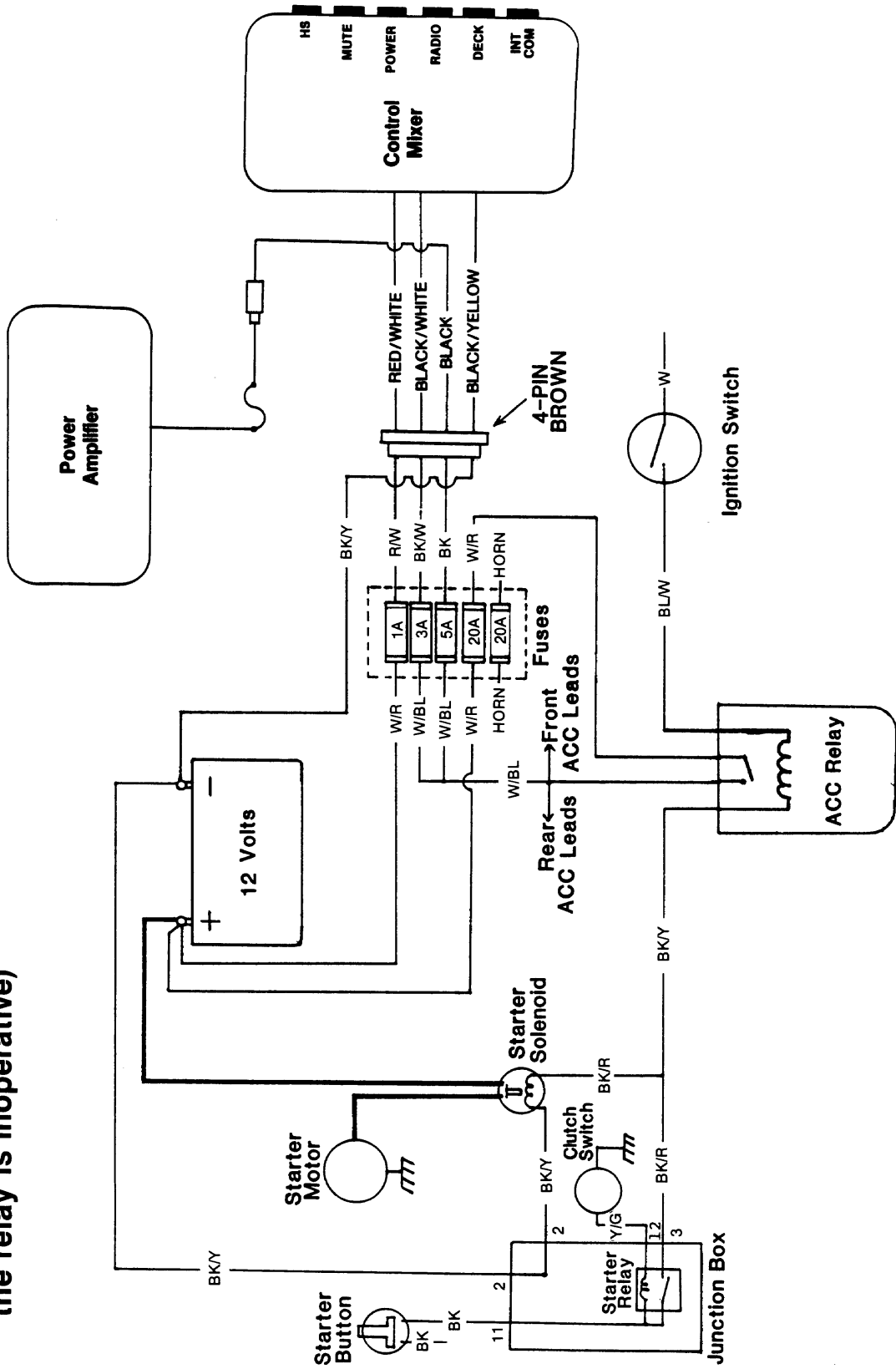

Standard System

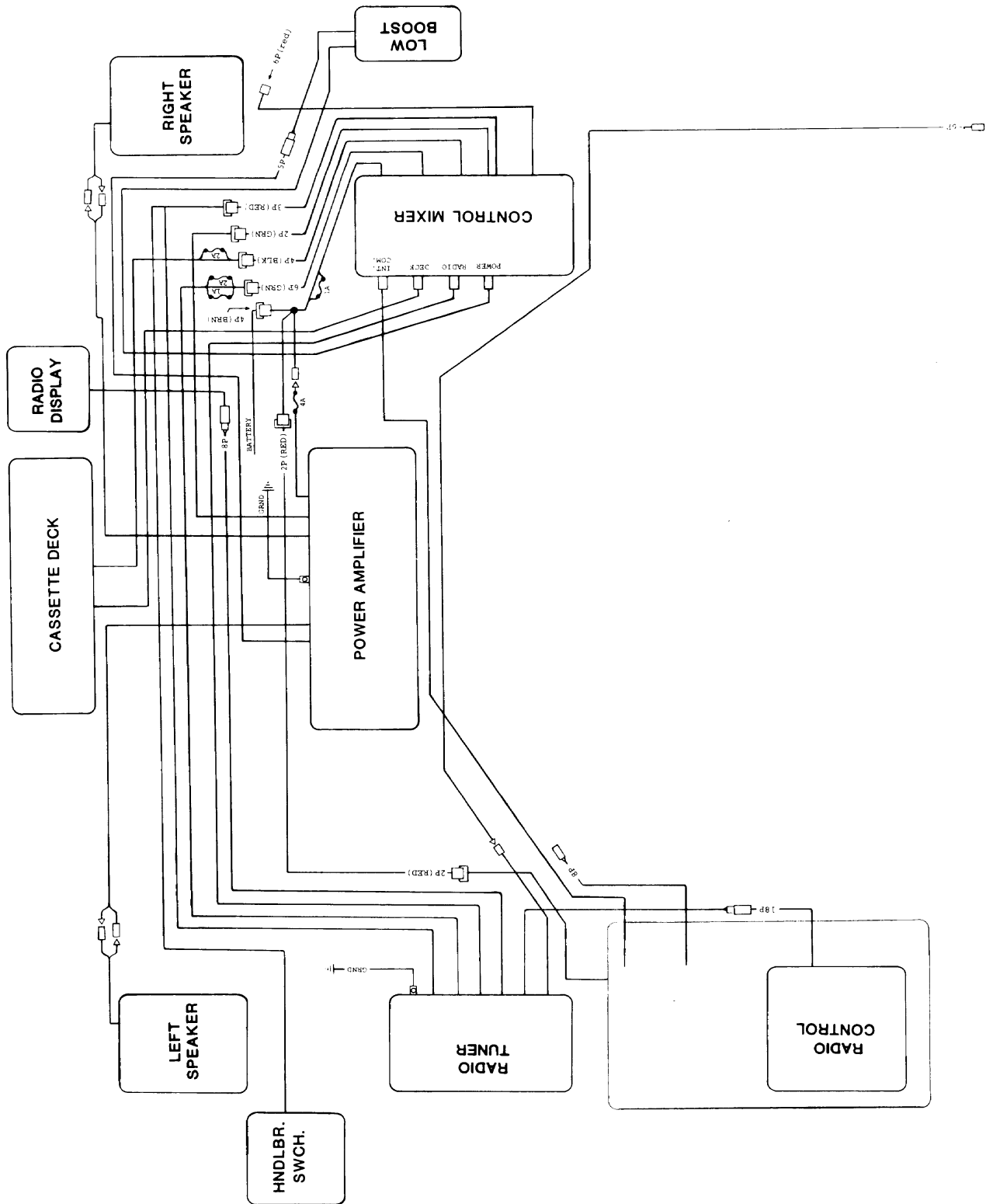

Optional System

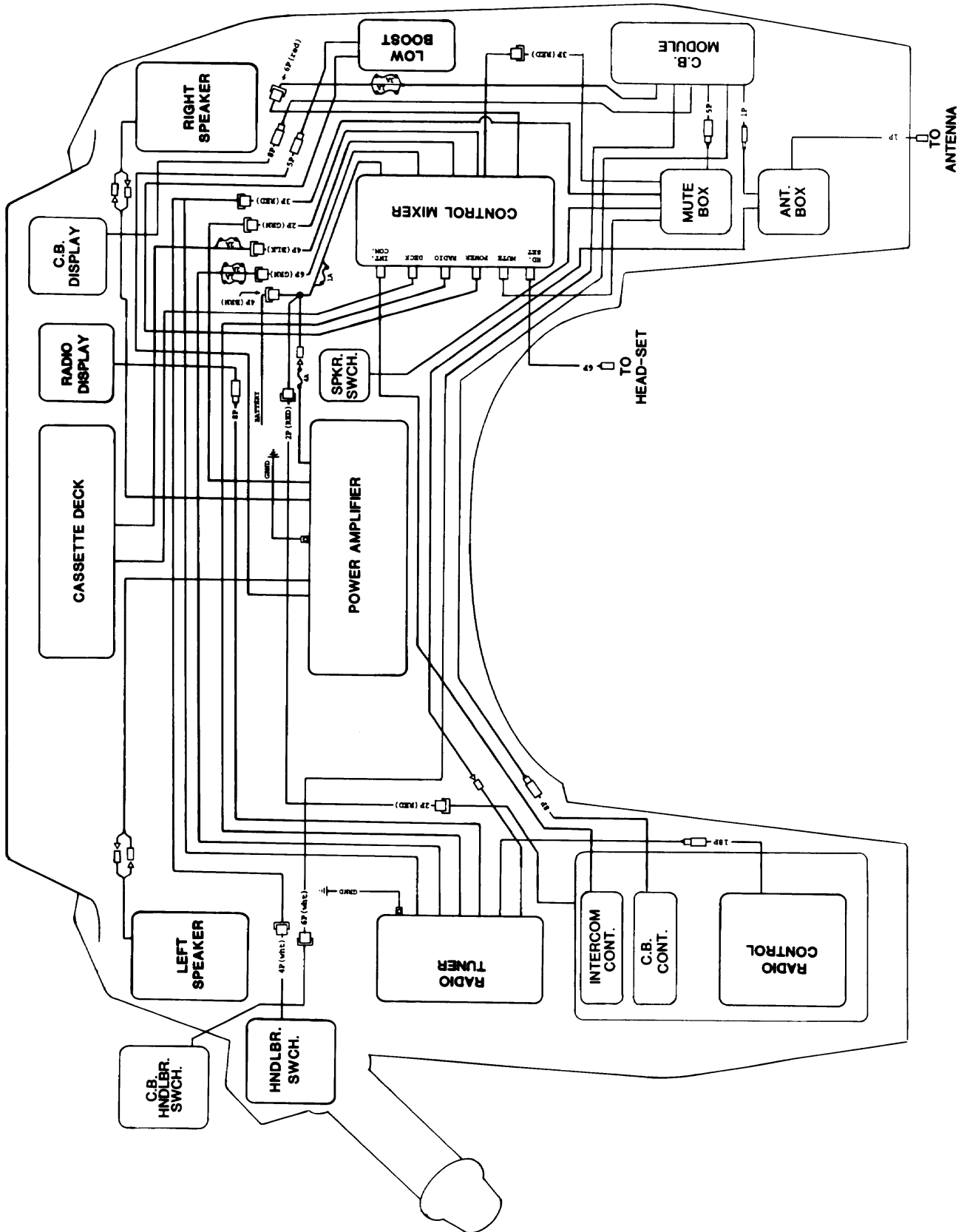

Special Test Harness

P/N T57001-285

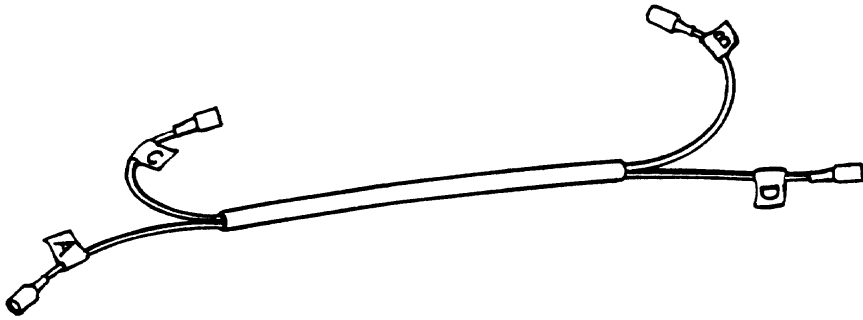

5 PIN FEMALE (B)

5 PIN FEMALE (A)

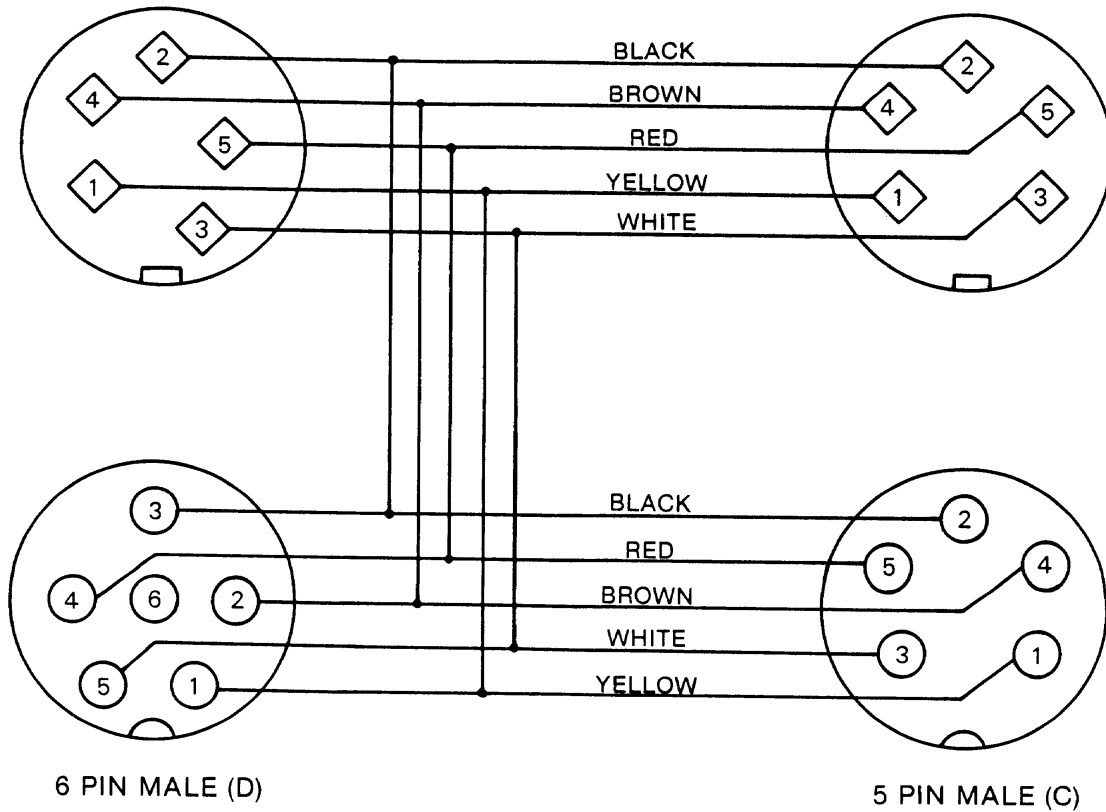

6 PIN MALE (D)

5 PIN MALE (C)

Power Amplifier

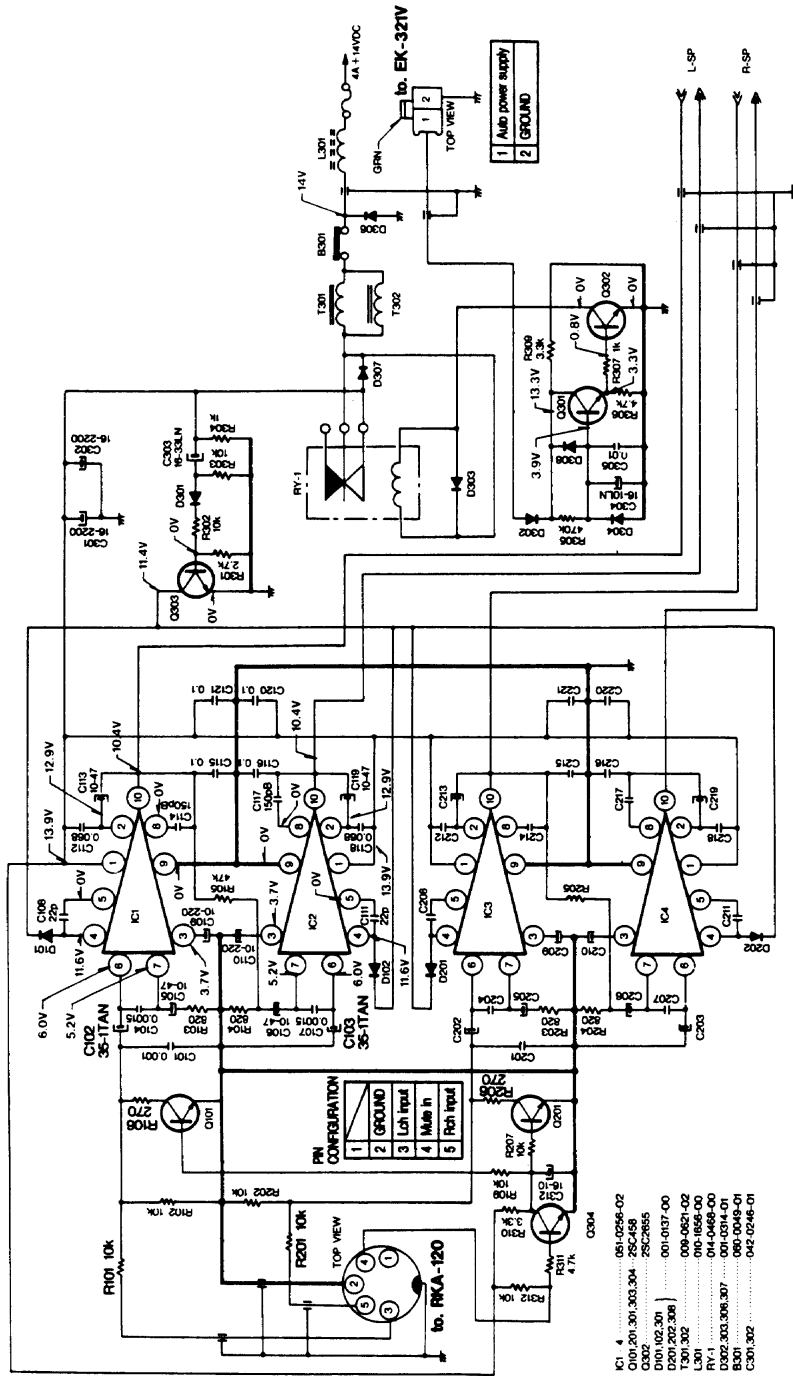

Radio Tuner

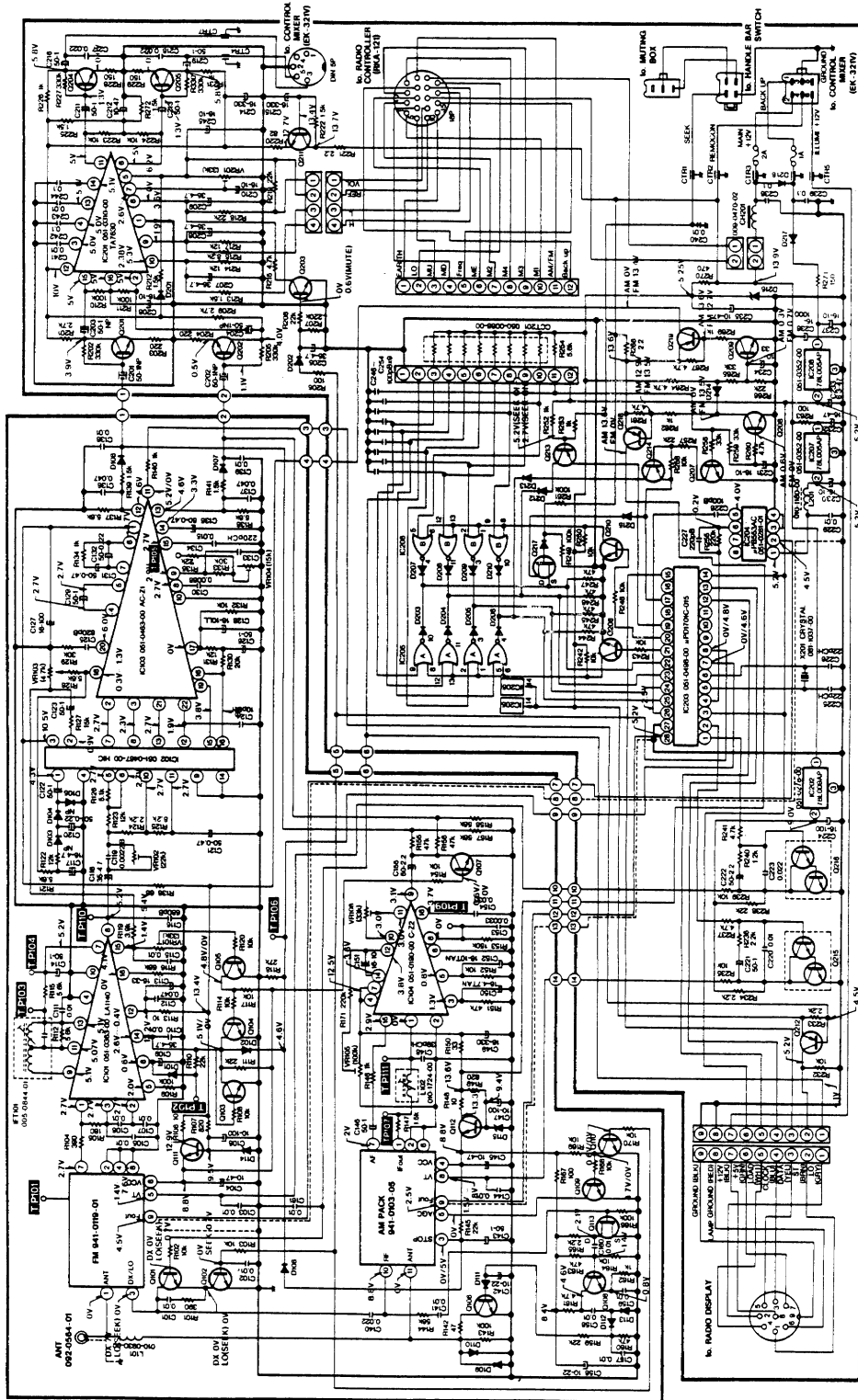

001R 010 020R 030R 040R 050R 060R 070R 080R 090R 100R 110R 120R 130R 140R 150R 160R 170R 180R 190R 200R 210R 220R 230R 240R 250R 260R 270R 280R 290R 300R 310R 320R 330R 340R 350R 360R 370R 380R 390R 400R 410R 420R 430R 440R 450R 460R 470R 480R 490R 500R 510R 520R 530R 540R 550R 560R 570R 580R 590R 600R 610R 620R 630R 640R 650R 660R 670R 680R 690R 700R 710R 720R 730R 740R 750R 760R 770R 780R 790R 800R 810R 820R 830R 840R 850R 860R 870R 880R 890R 900R 910R 920R 930R 940R 950R 960R 970R 980R 990R

Radio Controller

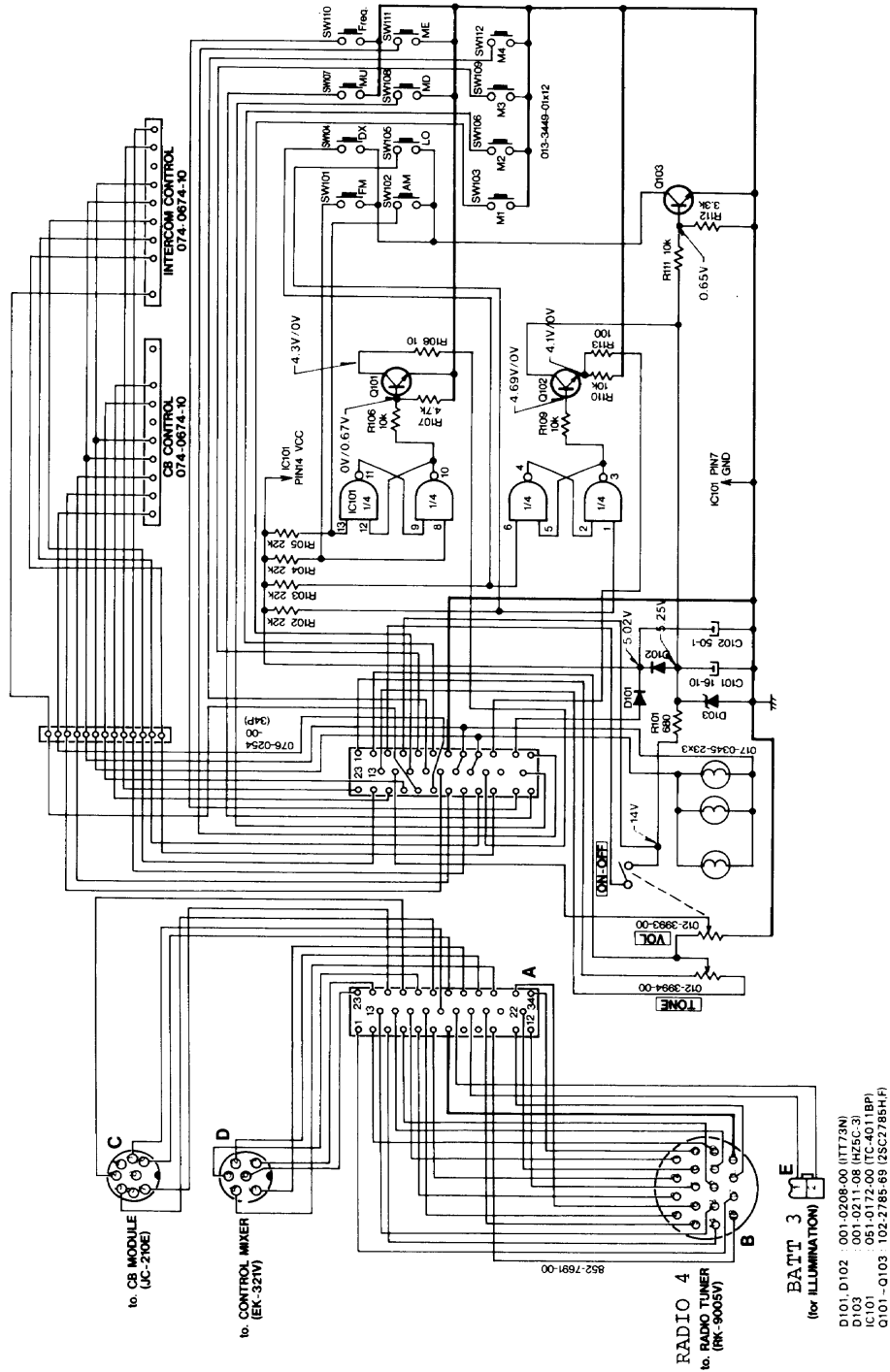

Cassette Deck

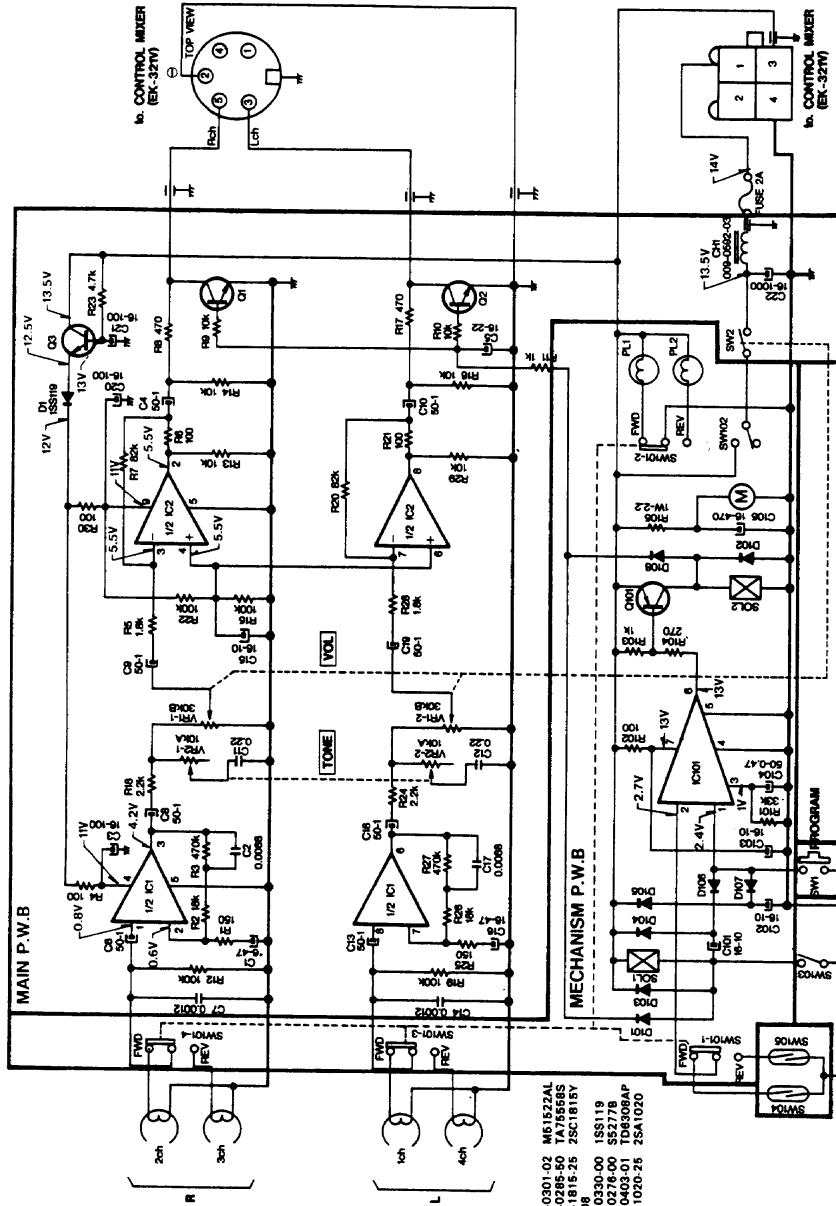

- IC1 051-0301-02 M61522AL
- IC2 051-0285-50 TA7556S
- Q1,2,3 102-1815-25 2SC1815Y
- D1,101,104 108-930-00 1S8118
- D102,103 001-0375-00 5S2778
- IC101 051-0403-01 TD8508AP
- Q101 100-1020-25 2SA1020

Radio/Clock Display

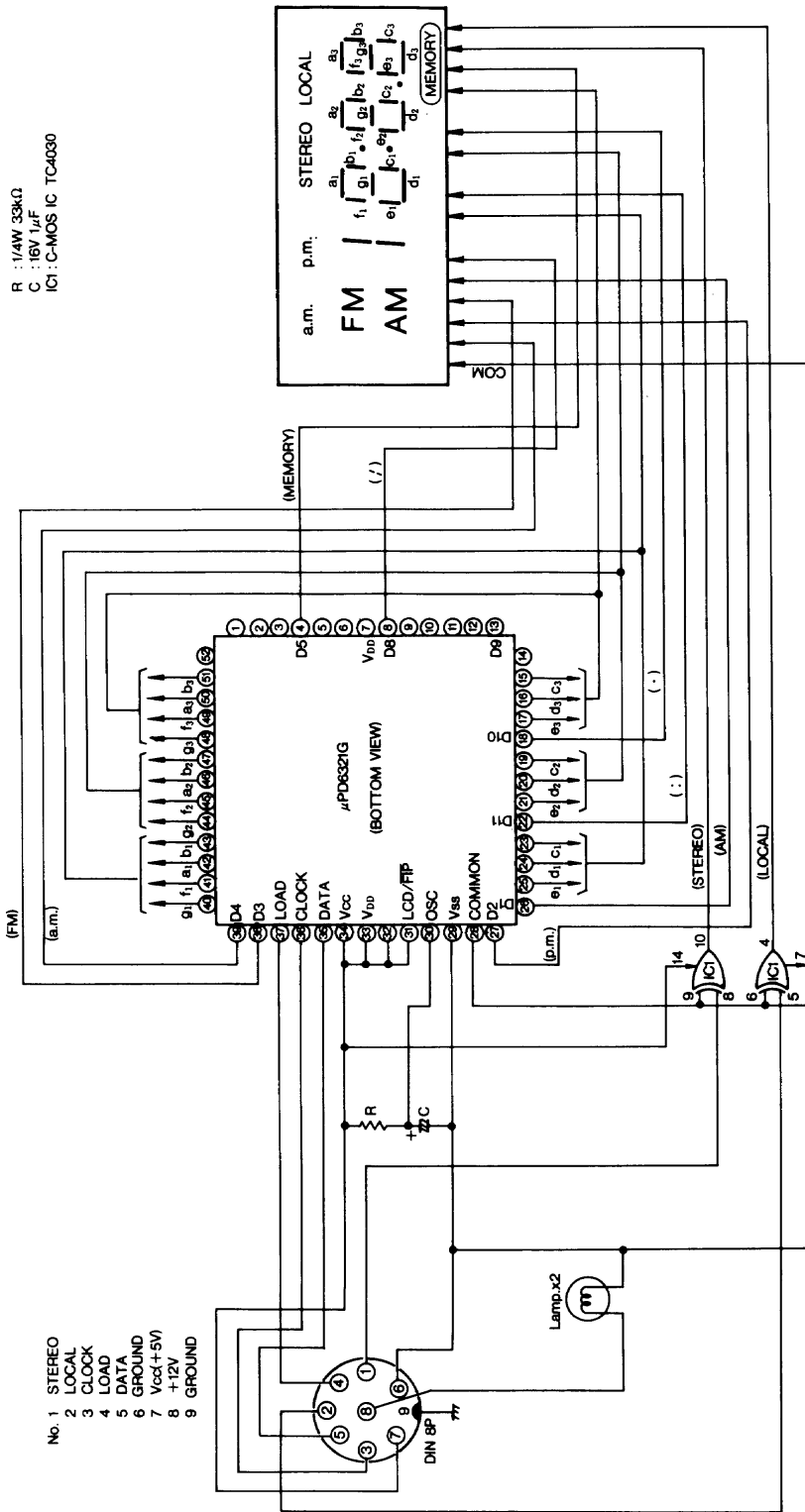

CB Module (Transceiver)

CB Controller

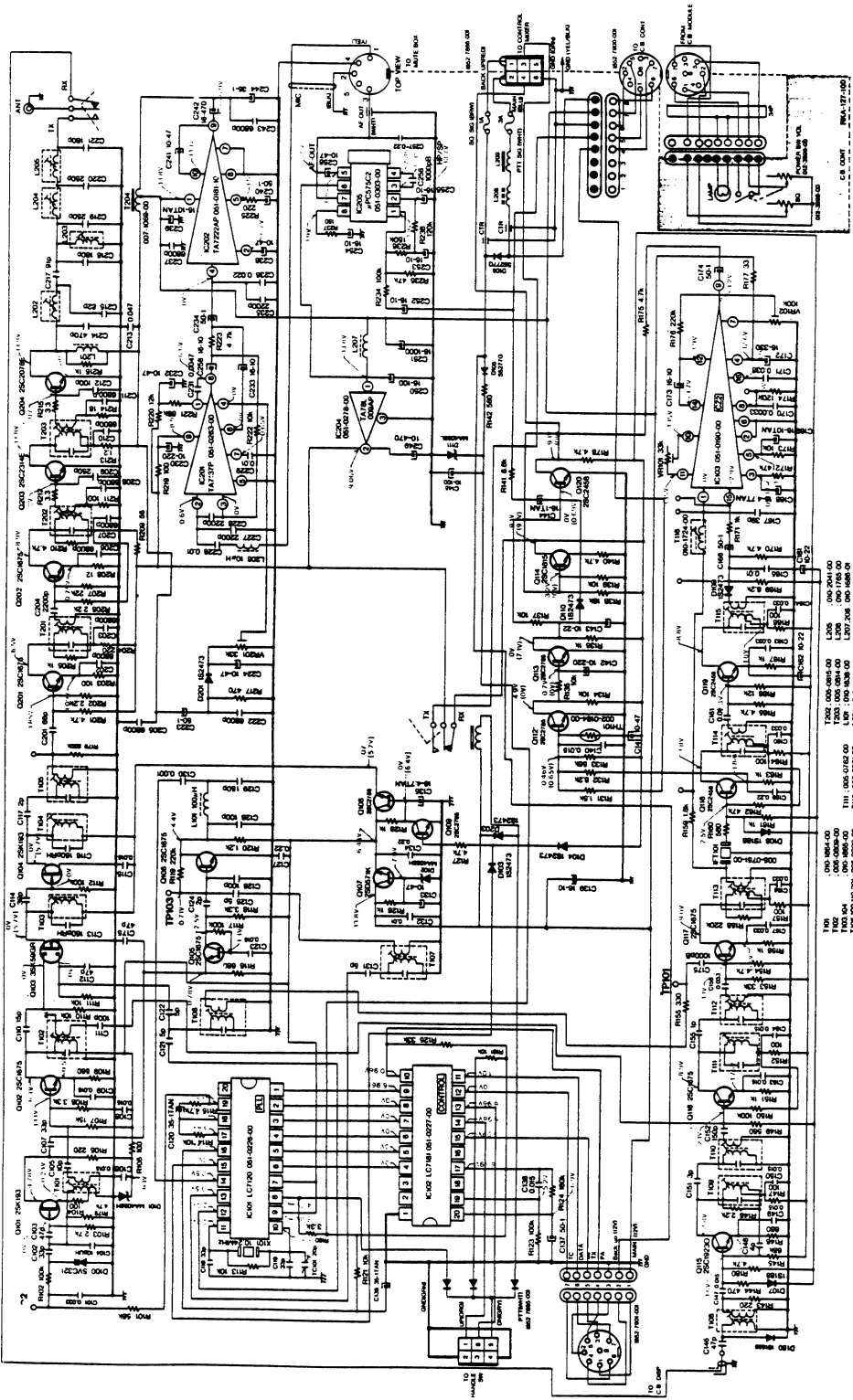

100	100K	0.001	0.001	0.001	0.001	0.001	0.001	0.001	0.001
101	100K	0.001	0.001	0.001	0.001	0.001	0.001	0.001	0.001
102	100K	0.001	0.001	0.001	0.001	0.001	0.001	0.001	0.001
103	100K	0.001	0.001	0.001	0.001	0.001	0.001	0.001	0.001
104	100K	0.001	0.001	0.001	0.001	0.001	0.001	0.001	0.001
105	100K	0.001	0.001	0.001	0.001	0.001	0.001	0.001	0.001
106	100K	0.001	0.001	0.001	0.001	0.001	0.001	0.001	0.001
107	100K	0.001	0.001	0.001	0.001	0.001	0.001	0.001	0.001
108	100K	0.001	0.001	0.001	0.001	0.001	0.001	0.001	0.001
109	100K	0.001	0.001	0.001	0.001	0.001	0.001	0.001	0.001
110	100K	0.001	0.001	0.001	0.001	0.001	0.001	0.001	0.001
111	100K	0.001	0.001	0.001	0.001	0.001	0.001	0.001	0.001
112	100K	0.001	0.001	0.001	0.001	0.001	0.001	0.001	0.001
113	100K	0.001	0.001	0.001	0.001	0.001	0.001	0.001	0.001
114	100K	0.001	0.001	0.001	0.001	0.001	0.001	0.001	0.001
115	100K	0.001	0.001	0.001	0.001	0.001	0.001	0.001	0.001
116	100K	0.001	0.001	0.001	0.001	0.001	0.001	0.001	0.001
117	100K	0.001	0.001	0.001	0.001	0.001	0.001	0.001	0.001
118	100K	0.001	0.001	0.001	0.001	0.001	0.001	0.001	0.001
119	100K	0.001	0.001	0.001	0.001	0.001	0.001	0.001	0.001
120	100K	0.001	0.001	0.001	0.001	0.001	0.001	0.001	0.001



CB Display

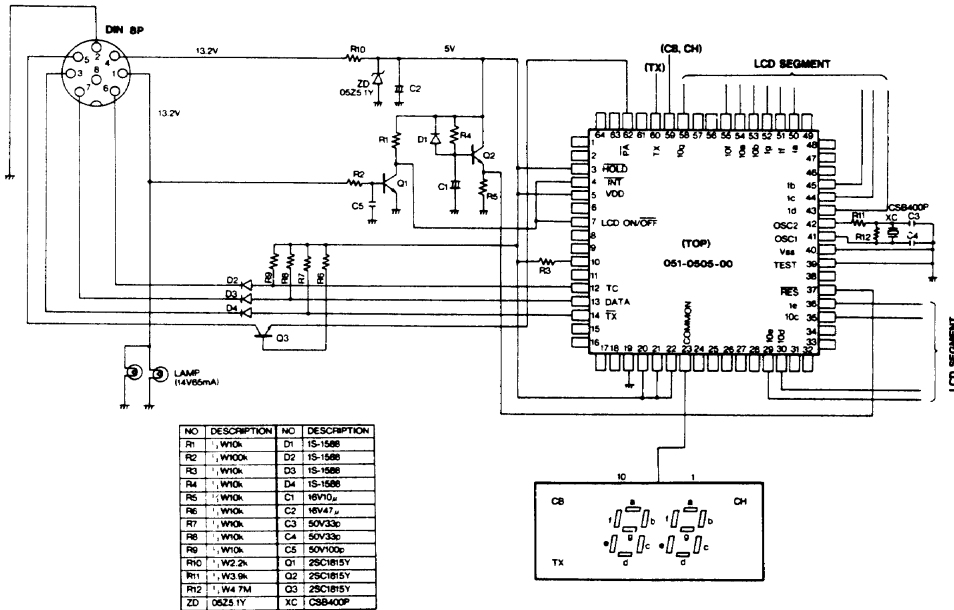

Low Booster

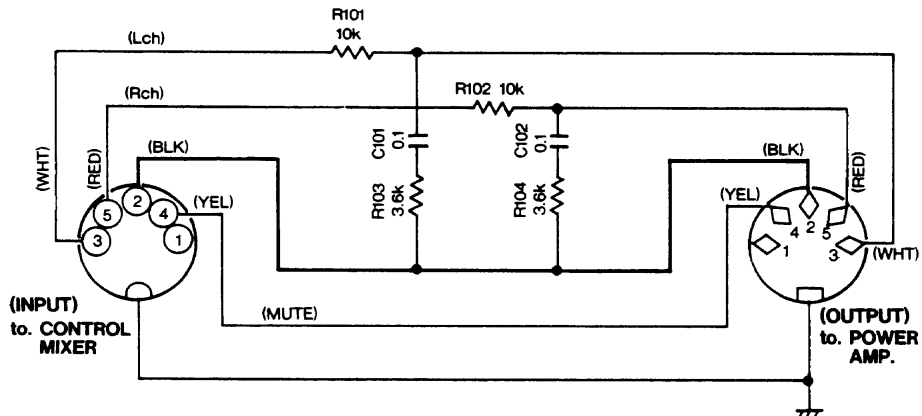

Mute Box

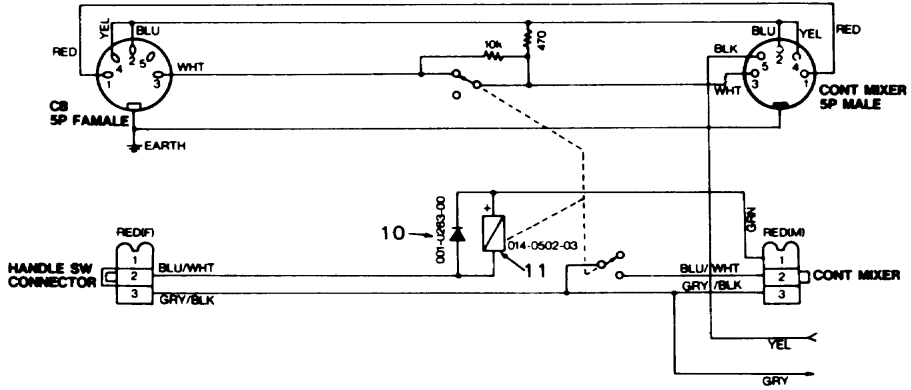

Intercom Controller

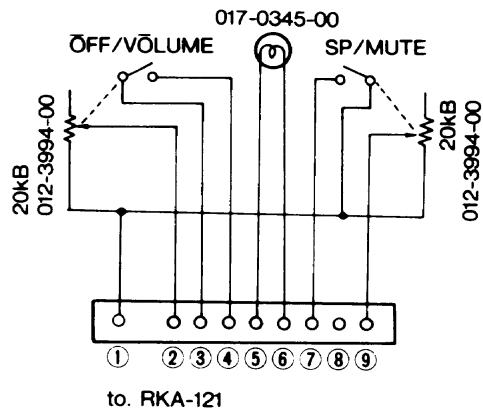

Antenna Box

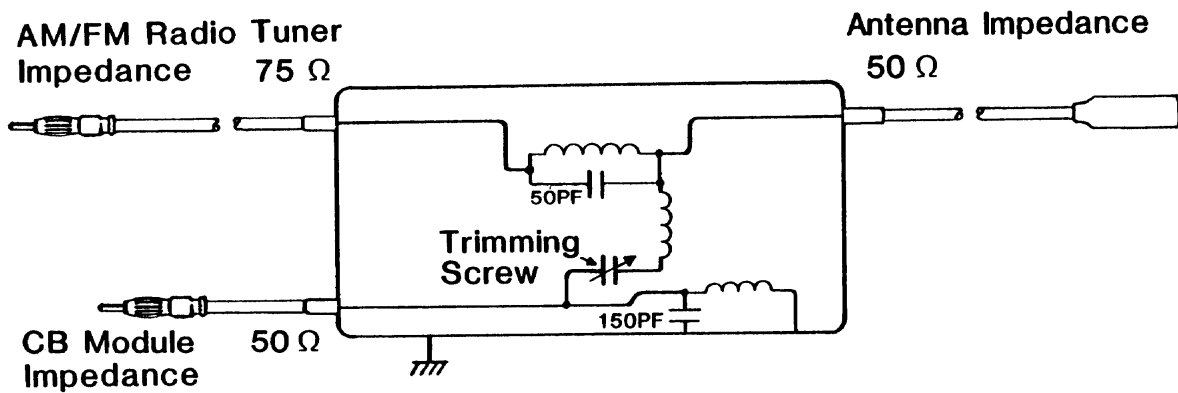

The AM/FM Radio and the CB Radio have different antenna requirements. An Antenna Box allows a single antenna to serve the needs of both radios by varying antenna circuit impedance.

COMPONENT CROSS-REFERENCE LIST

DESCRIPTION	KAWASAKI PART NUMBER	CLARION MODEL NUMBER
Cassette Deck	21182-1051	PK-8015V-A
Radio Controller	21178-1051	RKA-121-100
Radio Tuner	21179-1001	RK-9005V-A
Control Mixer	21177-1001	EK-321V-01
Low Booster	21181-1051	RKA-120-100
Power Amplifier	21181-1001	EK-322V-01
Intercom Controller	21178-1004	RKA-122-100
Radio Display	21186-1051	379-0053-00
C.B. Display	21186-1002	379-0060-00
C.B. Transceiver	21180-1001	JC-210E-01
C.B. Controller	21178-1003	RKA-127-100
Mute Box	27010-1163	RKA-124-100
Antenna Box	21183-1002	093-079-902
Antenna	21183-1051	PAS-178-100
Speaker, left	21185-1051	SPA-856-101
Speaker, right	21185-1001	SPA-856-102

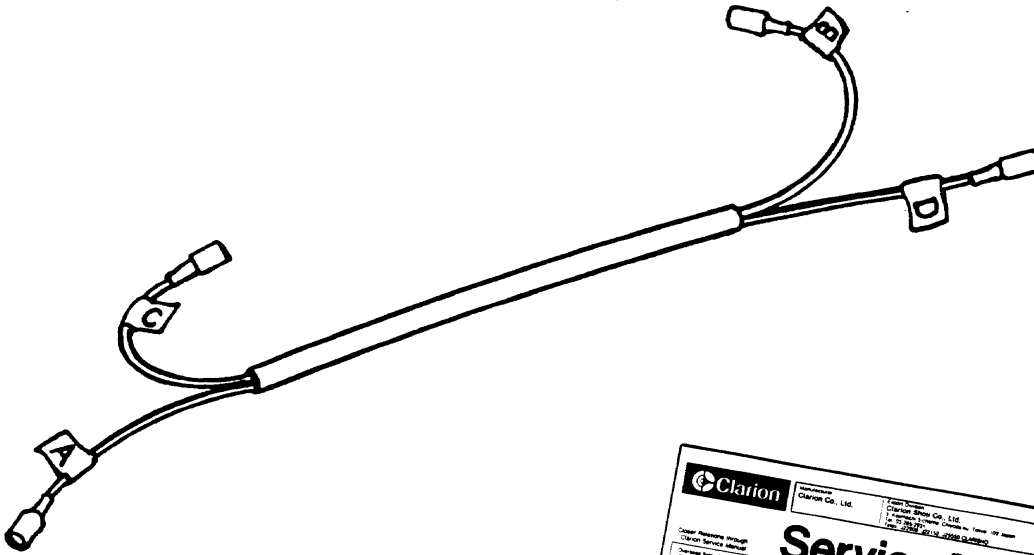

Clarion Service Manual
KAWASAKI MOTORCYCLE GENUINE CB TRANSCEIVER
 Model **JC-210E**

SPECIFICATIONS:

- Channels: 40 CH
- Frequency control system: PLL
- Antenna impedance: 50 ohms
- Power supply voltage: DC 14V
- Current consumption: Less than 2A
- Dimensions: Width 83mm, Height 90mm, Depth 115mm
- Weight: 1.3kg
- Receiver: Better than 80dB at 10dB S/N
- Quarrying sensitivity: 10dB
- Auto lockout: More than 80dB
- ADC PWR: Less than 80dB
- Search sensitivity: 30-50dB
- IF stage: 1st 10dB, 2nd 10dB, 3rd 10dB
- Selectivity: 4W max/14.0V, 57% S/N, 13dB 50% Modulation
- Transmitter IC output: More than 100W
- Modulation sensitivity: More than 50dB
- Sprinkle suppression: Less than 100W
- S/N ratio: More than 45dB

COMPONENTS:

- JC-210E-01: 013-3724-00
- Main set: 013-3725-00
- Switch: 013-3728-00
- IGP (used set in CB): 013-3728-00
- Switch: 300-8878-00
- Switch: 300-8879-00
- Switch: 092-9789-02
- Mounting bracket: 338-174-00
- Mounting bracket: 364-124-00
- Antenna armature: 464-121-00
- Bracket: 378-0060-00
- Mounting base: 483-0123-01
- CB controller: 120-0134-00
- Indicator: 130-5030-00
- Fuse bag (A): 281-0706-00
- Fuse bag (B): 338-1732-00
- Fuse bag (C): 718-0818-00
- Parts bag: 1485-19
- Screw: 718-0917-00
- Screw: 718-0818-00
- Screw: M5x8
- Screw: 723-2000-20
- Screw: M6x
- Hex nut: 743-0925-02
- Washer: 884-122-100
- Motor com.

Printed in Japan 298-3082-00

Clarion Service Manual
KAWASAKI MOTORCYCLE GENUINE Radio & Cassette Deck
 Model **RK-9005V · PK-8015V**
EK-321V · EK-322V

Printed in Japan 298-2982-00

VOYAGER TEST HARNESS
Kawasaki P/N T57001-285

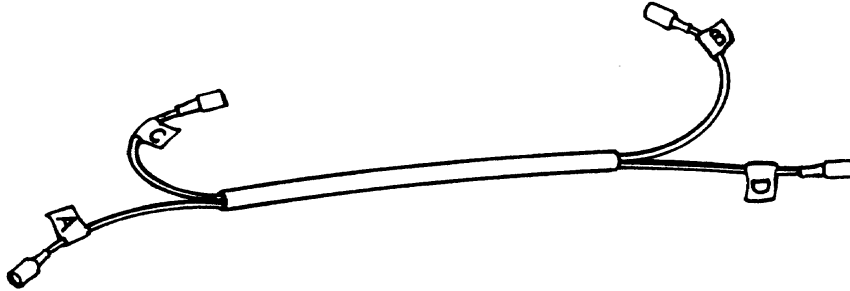

S.W.R. ADAPTER LEADS
Kawasaki P/N T57001-286

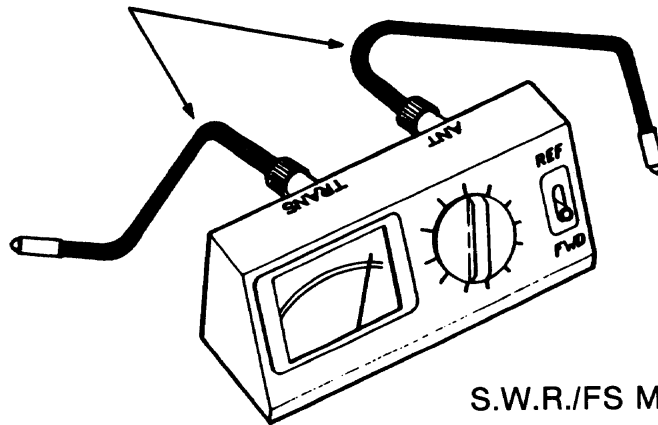

S.W.R./FS Meter

Meter available from local supply source. Brand is not important. (Radio Shack model #21-525B shown)

COMPONENT LEVEL SERVICE MANUALS

These Service Manuals are available from Clarion Corporation of America
Western Division: 5500 Rosecrans Ave., Lawndale, California 90260 USA
Tel: 213-973-1100 Telex: CLARIONLSA 66-4447

Eastern Division: 100 Thirteenth Ave., Ronkonkoma, New York 11779 USA
Tel: 516-467-1120 Telex: 64-0787



Manufacturer
Clarion Co., Ltd.

Export Division
Clarion Shoji Co., Ltd.
3, Kojimachi 3-chome, Chiyoda-ku, Tokyo 102, Japan
Tel: 03 265 2931
Telex: J29008 J22152 J25550 CLARISHO

Service Manual

Closer Relations Through
Clarion Service Manual

Overseas Sales Branch Offices
 Clarion Corporation of America 5500 Rosecrans Ave. Lawndale, Calif. 90260 USA Tel: 213 973 1100 Telex: CLARIONLSA 66-4447
 Clarion Corporation of America (Eastern Division) 100 Thirteenth Avenue Ronkonkoma, New York 11779 USA Tel: 516-467-1120 Telex: 64-0787
 Clarion Shoji (EUROPA) G.m.B.H. Rudolf Diesel-Strasse 2, 6226 Eschborn 2, West Germany Tel: 06173 61041 42 Telex: 415414
 Clarion (HONG KONG) Co., Ltd. 526 Ocean Centre, Canton Road, Tsimshatsui, Kowloon, Hong Kong Tel: 3690528 Telex: H064293 CLAHK
 Clarion Canada Inc. 1401 Meyerside Dr. Mississauga, Ontario L5T 1G8, Canada Tel: 416-678-1387 Telex: J16968573 CLARION MSCA
 Clarion Shoji (U.K.) Ltd. 4-6 Faraday Road, Dorcan Industrial Estate, Dorcan, Swindon, Wiltshire SN3 2SH United Kingdom Tel: 07933 26681 Telex: 44669

KAWASAKI MOTORCYCLE GENUINE CB TRANSCEIVER

Model JC-210E

■ SPECIFICATIONS:

General
 Number of channels: 40 CH
 (26.965 - 27.405 MHz)

Frequency control system:
 PLL
 Local OSC 10.24 MHz
 crystal

Antenna impedance: 50 ohms
 DC 14V
 (Negative ground)

Current consumption:
 Less than 3A

Dimensions:
 Width 163mm
 Height 60mm
 Depth 115mm

Weight:
 1.3kg

Receiver
 Quieting sensitivity: Better than 8dB_r
 (at 10dB S/N)
 1kHz=0dB

Audio fidelity:
 0.4kHz - 2 ± 3dB
 3kHz - 9 ± 5dB
 More than 80dB

AGC FOM:
 Squelch sensitivity:
 Threshold
 Tight
 Less than 8dB_r
 30 - 55dB

IF stage:
 1st 10.695MHz
 2nd 45.5kHz

Selectivity:
 More than 50dB
 (at ± 10kHz detune)

Transmitter
 RF output:
 4W max / 14.0V
 -57 ± 6dBm
 (1kHz, 50%
 Modulation)

Spurious suppression:
 More than 60dB

Frequency tolerance:
 Less than ± 0.005%

S/N ratio:
 More than 45dB



■ COMPONENTS:

● JC-210E-01		
Main unit		1
Switch	013-3724-00	1
(SP/Head set at CB)		
Switch	013-3725-00	1
(Press talk for passenger)		
Switch	013-3726-00	1
(TALK/DN-UP)		
Mounting bracket	300-6878-00	1
Mounting bracket	300-6879-00	1
Antenna jumper	093-0799-02	1
Pocket	335-1775-00	1
Muting box	RKA-124-100	1
CB controller	RKA-127-100	1
Indicator	379-0060-00	1
Fuse bag	923-0123-01	1
Fuse (1A)	120-1010-00	2
Fuse bag	923-0124-00	1
Fuse (3A)	120-0030-00	2
Parts bag	921-7705-00	1
	335-1733-00	1
	716-0516-00	2
Screw	(M5x16)	
	716-0517-00	4
Screw	(M5x12)	
	716-0518-00	4
Screw	(M5x8)	
	723-5000-20	2
Hex nut	(M5)	
	745-0625-02	4
Washer	RKA-122-100	1
● Inter com		

Printed in Japan 298-3082-00

JC-210E



Manufacturer
Clarion Co., Ltd.

Export Division
Clarion Shoji Co., Ltd.
3, Kojimachi 3-chome, Chiyoda-ku, Tokyo 102, Japan
Tel: 03 265 2931
Telex: J29008 J22152 J25550 CLARISHO

Service Manual

Closer Relations Through
Clarion Service Manual

Overseas Sales Branch Offices
 Clarion Corporation of America 5500 Rosecrans Ave. Lawndale, Calif. 90260 USA Tel: 213 973 1100 Telex: CLARIONLSA 66-4447
 Clarion Corporation of America (Eastern Division) 100 Thirteenth Avenue Ronkonkoma, New York 11779 USA Tel: 516-467-1120 Telex: 64-0787
 Clarion Shoji (EUROPA) G.m.B.H. Rudolf Diesel-Strasse 2, 6226 Eschborn 2, West Germany Tel: 06173 61041 42 Telex: 415414
 Clarion (HONG KONG) Co., Ltd. 526 Ocean Centre, Canton Road, Tsimshatsui, Kowloon, Hong Kong Tel: 3690528 Telex: H064293 CLAHK
 Clarion Canada Inc. 1401 Meyerside Dr. Mississauga, Ontario L5T 1G8, Canada Tel: 416-678-1387 Telex: J16968573 CLARION MSCA
 Clarion Shoji (U.K.) Ltd. 4-6 Faraday Road, Dorcan Industrial Estate, Dorcan, Swindon, Wiltshire SN3 2SH United Kingdom Tel: 07933 26681 Telex: 44669

KAWASAKI Motorcycle Genuine Radio & Cassette Deck

Model RK-9005V · PK-8015V EK-321V · EK-322V



RK-9005V



PK-8015V

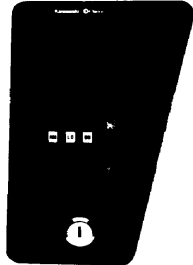

RKA-121

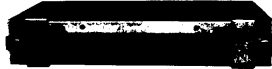

EK-322V



EK-321V

Printed in Japan 298-2982-00

RK-9005V
PK-8015V

This Service Manual covers the CB Transceiver, Intercom Controller, Mute Box, CB Controller, and CB Display

This Service Manual covers the Cassette Deck, Power Amplifier, Control Mixer, Radio Control, and Radio Tuner