

# MOUNTING INSTRUCTIONS

VOYAGER XII  
TRAILER HITCH

P/N 090025

QTY	P/N	DESCRIPTION
2	303147	8 x 1.25 x 75mm HEX HEAD CAP SCREW, PLATED
2	302308	8 x 1.25mm HEX NYLOCK NUT, PLATED
6	303172	1/4" 20 x 1 1/4" HEX HEAD CAP SCREW, PLATED
6	302320	1/4" 20 HEX NYLOCK NUT, PLATED
12	301121	1/4 x .030" FLATWASHER, PLATED
6	303181	5/16" 18 x 1" HEX HEAD CAP SCREW, PLATED
2	303182	5/16" 18 x 1 1/4" HEX HEAD CAP SCREW, PLATED
8	302322	5/16" 18 HEX NYLOCK NUT, PLATED
28	301132	5/16" SAE FLATWASHER, PLATED
1	590040	HITCH BALL WITH BOLT AND LOCKWASHER, CHROME
1	301136	3/4" SAE FLATWASHER, PLATED
2	490635	ZG12 HITCH "C" STRUT, CHROME
1	690090	HITCH PLATE WELDMENT, CHROME
2	590060	HITCH INSERT ROD, PLATED
2	490645	ZG12 HITCH "B" STRUT, BPC
2	490640	ZG12 HITCH "A" STRUT, BPC
1	690245	ZG12 HITCH SUPPORT WELDMENT RH, BPC
1	690240	ZG12 HITCH SUPPORT WELDMENT LH, BPC

1. PLACE YOUR MOTORCYCLE ON ITS CENTERSTAND, AND THEN REMOVE THE SADDLEBAGS FROM THEIR MOUNTS. SET THEM ASIDE FOR NOW. LOCATE THE 8mm BOLTS THAT FASTEN THE SADDLEBAG GUARDS TO THE BLACK SADDLEBAG SUBFRAMES. REMOVE THESE BOLTS AND THE STAMPED CHROME COVERS.
2. LOCATE THE 8mm BOLTS THAT FASTEN THE SIDE OF THE TRUNK MOUNTING RACK TO THE MOTORCYCLE FRAME. REMOVE THESE BOLTS (ONE SIDE AT A TIME, TO PREVENT THE RACK FROM SLIPPING OUT OF POSITION) AND THEN DRILL OUT THE THREADS IN THE WELD-NUT USING A 5/16" BIT. SLIDE THE 8 x 75mm BOLTS WITH FLATWASHERS INTO THESE HOLES, AND LEAVE LOOSE FOR NOW.
3. PULL FORWARD SLIGHTLY ON THE SADDLEBAG GUARD SO YOU CAN SLIDE THE FRONT MOUNTING BRACKET OF THE HITCH SUPPORTS ONTO THE SADDLEBAG SUBFRAMES (SEE FIGURE ONE), REINSTALL THE 8mm BOLTS AND CHROME COVERS THAT FASTEN THE GUARD TO THE SUBFRAME, AND TIGHTEN JUST TILL SNUG FOR NOW. NOTE: IF THE CHROME COVER HITS THE HITCH SUPPORT MOUNT BRACKET, YOU MAY SPACE OUT THE COVER BY INSTALLING 5/16" FLATWASHERS BETWEEN THE SADDLEBAG GUARD AND THE COVER. EIGHT WASHERS (TWO PER BOLT) HAVE BEEN INCLUDED IN THE KIT FOR THIS PURPOSE.
4. FASTEN THE "B" STRUTS TO 8 x 75mm BOLTS THAT YOU INSTALLED IN STEP TWO, USING THE 8mm LOCKNUTS AND FLATWASHERS PROVIDED. THE HOLE IN THE CENTER SHOULD BE CLOSEST TO THE TOP HOLE WHEN MOUNTED CORRECTLY. FASTEN THE LOWER END OF THE "B" STRUTS TO THE INSIDE OF THE TAB ON THE HITCH SUPPORT USING 5/15 x 1" BOLTS, FLATWASHERS, AND LOCKNUTS PROVIDED. LEAVE THESE BOLTS LOOSE FOR NOW. SEE FIGURE TWO.

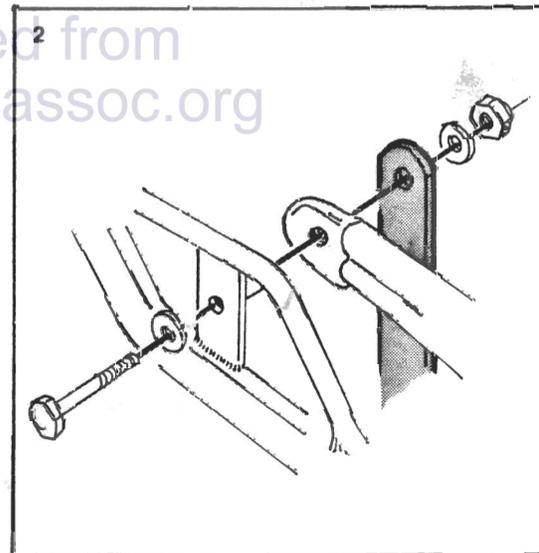
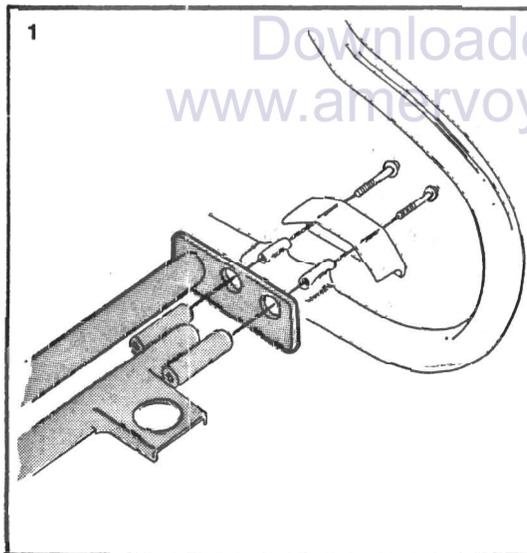

5. SLIDE THE INSERT RODS INTO THE ENDS OF THE HITCH SUPPORTS, AND FASTEN WITH THE 1/4 x 1 1/4" BOLTS, FLATWASHERS, AND LOCKNUTS PROVIDED. SLIDE THE HITCH PLATE ONTO THE INSERT RODS AND FASTEN WITH THE REMAINING 1/4 x 1 1/4" BOLTS, FLATWASHERS, AND LOCKNUTS. LEAVE THESE LOOSE ALSO.

Continued on reverse side

15365 Barranca Parkway  
Irvine, CA. 92718

(714) 453-0531 FAX (714) 543-8912

MARKLAND

REV. JUN 1989

6. ATTACH THE "A" STRUTS TO THE OUTSIDE OF THE "B" STRUTS AT THE CENTER HOLE, USING 5/16 x 1" BOLTS, WASHERS, AND LOCKNUTS. ATTACH THE LOWER END OF THE "A" STRUTS TO THE INSIDE OF THE REAR TAB ON THE HITCH SUPPORTS, USING THE 5/16 x 1 1/4" BOLTS PROVIDED. ATTACH ONE END OF THE "C" STRUTS ALSO TO THESE BOLTS, SANDWICHING THE LOWER END OF THE "A" STRUTS BETWEEN "C" STRUT AND TAB. FASTEN WITH 5/16" FLATWASHERS AND LOCKNUTS. ATTACH THE REAR END OF THE "C" STRUTS TO THE OUTSIDE OF THE TABS ON THE HITCH PLATE, USING THE 5/16 x 1" BOLTS, FLATWASHERS, AND LOCKNUTS PROVIDED.
7. CHECK THAT THE HITCH PLATE IS CENTERED, AND LEVEL SIDE-TO-SIDE, AND THEN SECURELY TIGHTEN ALL NUTS AND BOLTS. FASTEN THE HITCH BALL TO THE HITCH PLATE WITH THE 3/4" BOLT AND WASHERS PROVIDED. TIGHTEN SECURELY. REINSTALL THE SADDLEBAGS AND INSTALLATION IS COMPLETE.

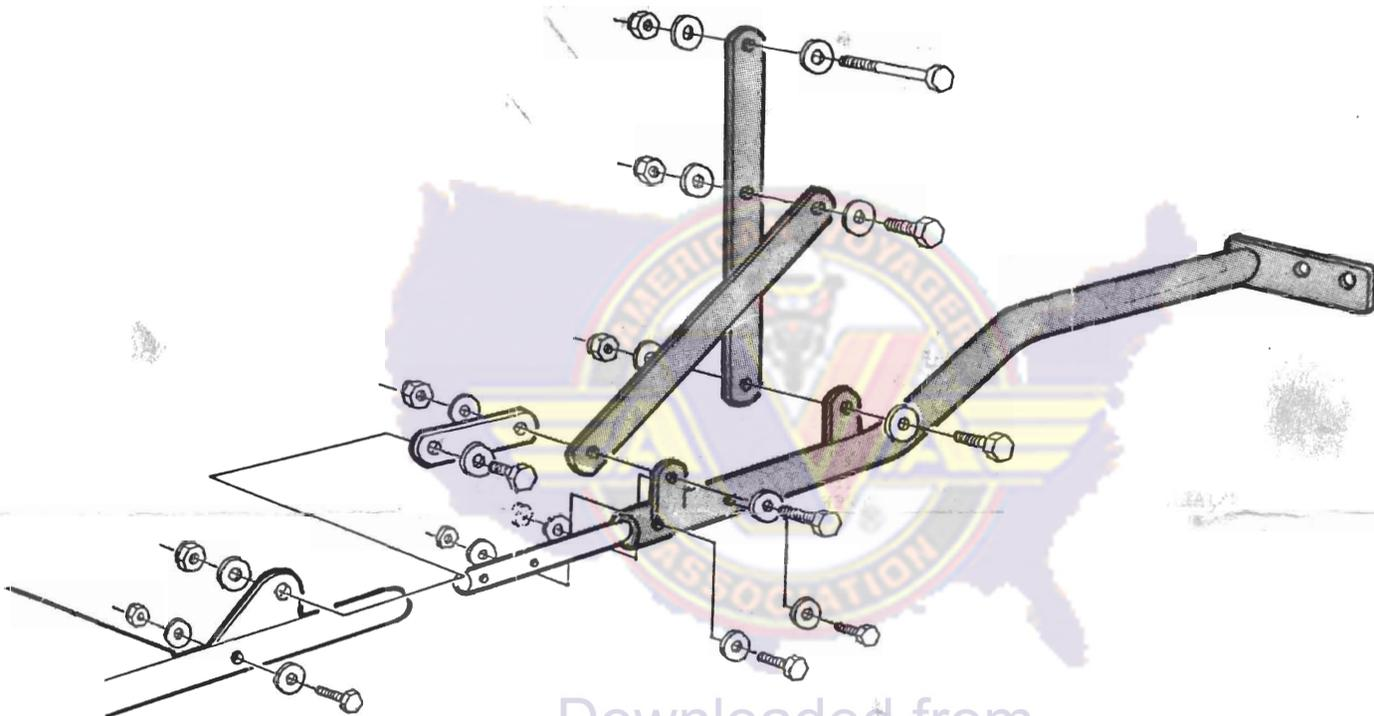

Downloaded from  
[www.amervoyassoc.org](http://www.amervoyassoc.org)  
R.H. SIDE SHOWN