

VOYAGER XII TRAVEL TRUNK RAILS P/N K53002-004

| QTY | P/N | DESCRIPTION |
|-----|--------|---|
| 2 | 720108 | #10 CAPLUG CAP |
| 2 | 720109 | #10 CAPLUG WASHER |
| 2 | 304393 | 10-32 X 1 1/2 PHILLIPS FLATHEAD SCREW, PLATED |
| 2 | 301901 | #10 RUBBER WASHER |
| 2 | 302510 | 10-32 KEPS NUT, PLATED |
| 1 | 420970 | TRUNK RAIL END CAP LH, CHROME |
| 1 | 420975 | TRUNK RAIL END CAP RH, CHROME |
| 2 | 970312 | KAWASAKI TRUNK RAIL NAMEPLATE |
| 1 | 920102 | ZG12 TRUNK RAIL ASSEMBLY |

1. PLACE YOUR MOTORCYCLE ON ITS CENTERSTAND. UNLATCH AND FULLY OPEN THE TRUNK LID, ALLOWING IT TO REST ON THE PASSENGER SEAT. REMOVE THE LATCH ASSEMBLIES FROM THE TRUNK BODY; THESE ARE HELD IN PLACE WITH THREE ACORN NUTS EACH. SET THESE ITEMS ASIDE FOR NOW.
2. TO PROTECT THE BODY OF THE TRUNK DURING INSTALLATION, MASK OFF THE SIDES OF THE TRUNK NEAR THE FRONT CORNER, USING MASKING TAPE. THIS WILL ALSO KEEP THE DRILL BIT FROM WANDERING WHEN YOU DRILL THE TWO MOUNTING HOLES.
3. SLIDE THE RAIL ASSEMBLY UNDER THE TRUNK AND THEN UP INTO POSITION. FASTEN THE REAR MOUNTING BRACKETS TO THE TRUNK BODY USING THE LATCHES AND ACORN NUTS YOU REMOVED IN STEP NUMBER ONE. TIGHTEN THESE NUTS JUST UNTIL SNUG FOR NOW.

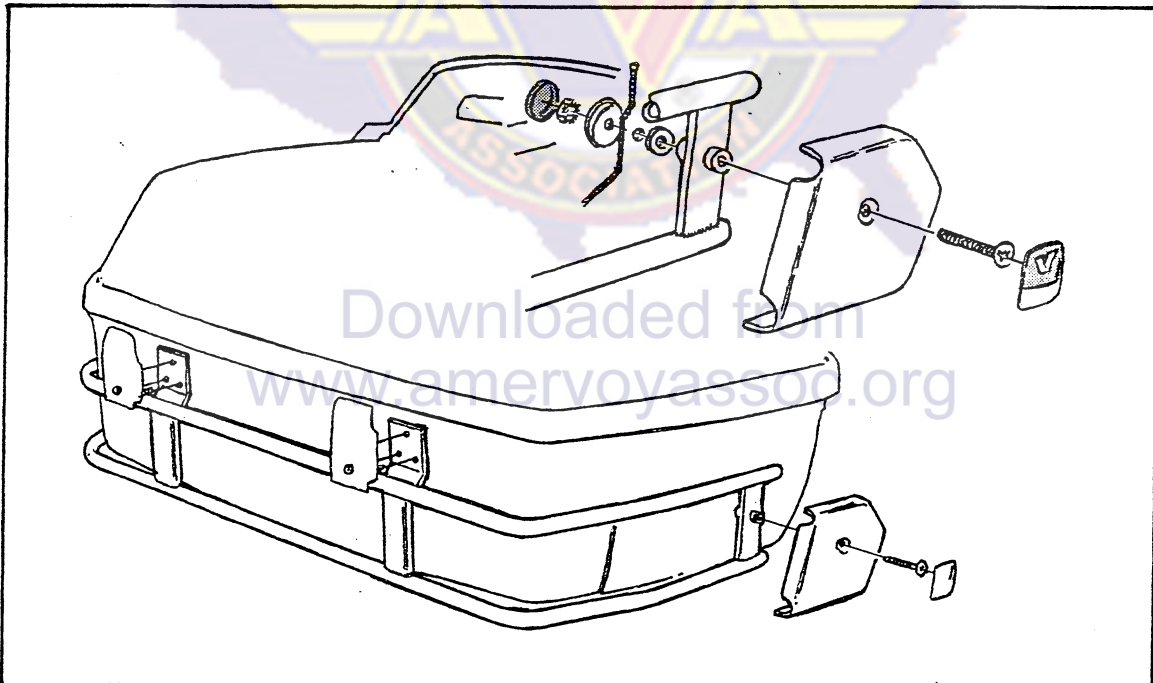

4. LOCATE THE FORWARD END OF THE TRUNK RAILS SO THEY ARE PARALLEL WITH THE TOP EDGE OF THE TRUNK BODY. USING A 3/16" BIT, DRILL THROUGH THE MOUNT BUSHING INTO THE TRUNK BODY. REMOVE THE MASKING TAPE (PEEL SLOWLY, TOWARDS THE HOLE, TO AVOID PULLING UP PAINT) AND THEN DEBURR THE HOLES, INSIDE AND OUT.
5. POSITION THE CHROME END CAPS ON THE FORWARD END OF THE RAILS, AND THEN FASTEN CAP AND RAIL TO THE TRUNK BODY, USING THE 10-32 PHILLIPS SCREWS, #10 RUBBER WASHERS, #10 CAPLUG WASHERS, AND 10-32 KEPS NUTS PROVIDED. TIGHTEN THESE SCREWS JUST UNTIL THE RUBBER WASHERS (BETWEEN RAIL AND TRUNK BODY) BEGIN TO COMPRESS. SECURELY TIGHTEN THE SIX ACORN NUTS THAT FASTEN THE LOCK BODIES TO THE TRUNK, AND SNAP THE BLACK CAPLUG CAPS OVER THE CAPLUG WASHERS INSIDE THE TRUNK BODY.
NOTE: APPLY KAWASAKI P/N TB1401 THREAD LOCK BEFORE INSTALLING THE ACORN NUTS.

NOTE: DO NOT UNDER ANY CIRCUMSTANCES USE THESE TRUNK RAILS AS HAND HOLDS OR TIE-DOWN HOOKS. NEITHER THE RAILS OR THE TRUNK BODY HAVE BEEN DESIGNED FOR THIS USE!